

Service
Service
Service

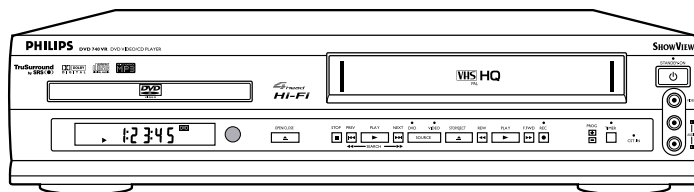

Service Manual

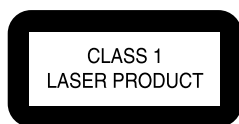

Contents	Page
Laser Beam Safety Precautions	1-1-1
Important Safety Precautions	1-2-1
Preparation for Servicing	1-3-1
Standart Notes for Servicing	1-4-1
Operating Controls and Functions	1-5-1
Signal Name Abbreviations	1-6-1
Cabinet Disassembly Instructions	1-7-1
Electrical Adjustment Instructions	1-8-1
Firmware Renewal Mode	1-9-1
Block Diagrams	1-10-1
Schematic Diagrams/CBA's and Test Points	1-11-1
Waveforms	1-12-1
Wiring Diagram	1-13-1
System Control Timing Charts	1-14-1
IC Pin Function Descriptions	1-15-1
Lead Identifications	1-16-1
Exploded Views	1-18-1
Spare Parts List	

© Copyright 2002 Philips Consumer Electronics B.V. Eindhoven, The Netherlands.
All rights reserved. No part of this publication may be reproduced, stored in a retrieval system or transmitted, in any form or by any means, electronic, mechanical, photocopying, or otherwise without the prior permission of Philips.



PHILIPS

MAIN SECTION

DIGITAL VIDEO DISC PLAYER & VIDEO CASSETTE RECORDER

Sec. 1: Main Section

- | Adjustment Procedures
- | Schematic Diagrams and CBA's
- | Exploded Views
- | Mechanical and Electrical Parts List

LASER BEAM SAFETY PRECAUTIONS

This DVD player uses a pickup that emits a laser beam.

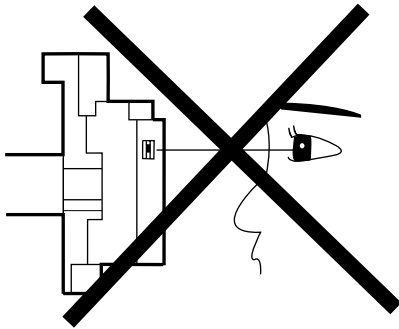

Do not look directly at the laser beam coming from the pickup or allow it to strike against your skin.

The laser beam is emitted from the location shown in the figure. When checking the laser diode, be sure to keep your eyes at least 30cm away from the pickup lens when the diode is turned on. Do not look directly at the laser beam.

Caution: Use of controls and adjustments, or doing procedures other than those specified herein, may result in hazardous radiation exposure.

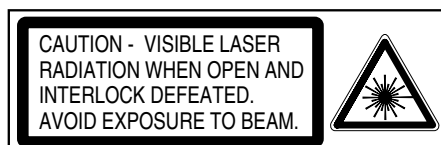
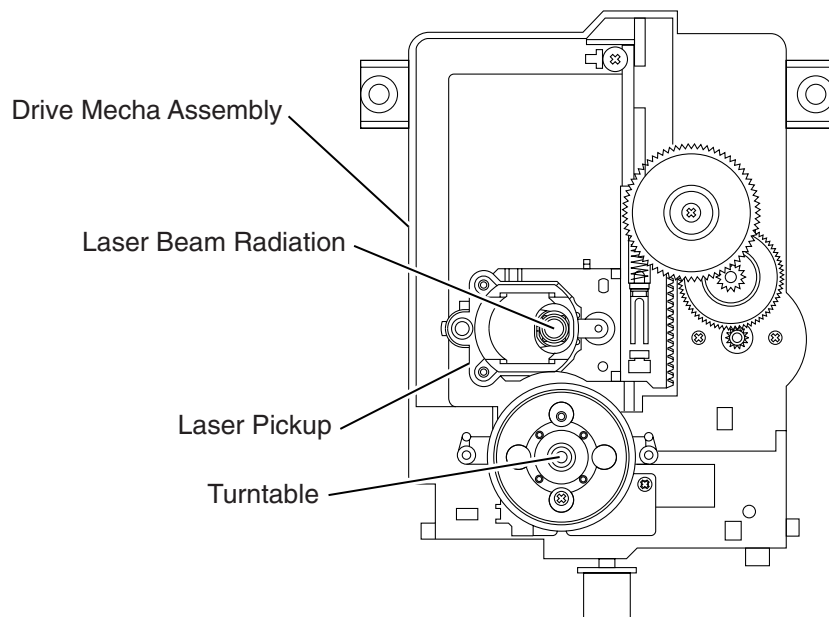

Location: Inside Top of DVD mechanism.

IMPORTANT SAFETY PRECAUTIONS

Product Safety Notice

Some electrical and mechanical parts have special safety-related characteristics which are often not evident from visual inspection, nor can the protection they give necessarily be obtained by replacing them with components rated for higher voltage, wattage, etc. Parts that have special safety characteristics are identified by a \triangle on schematics and in parts lists. Use of a substitute replacement that does not have the same safety characteristics as the recommended replacement part might create shock, fire, and/or other hazards. The Product's Safety is under review continuously and new instructions are issued whenever appropriate. Prior to shipment from the factory, our products are carefully inspected to confirm with the recognized product safety and electrical codes of the countries in which they are to be sold. However, in order to maintain such compliance, it is equally important to implement the following precautions when a set is being serviced.

Precautions during Servicing

- A.** Parts identified by the \triangle symbol are critical for safety. Replace only with part number specified.
- B.** In addition to safety, other parts and assemblies are specified for conformance with regulations applying to spurious radiation. These must also be replaced only with specified replacements.
Examples: RF converters, RF cables, noise blocking capacitors, and noise blocking filters, etc.
- C.** Use specified internal wiring. Note especially:
 - 1) Wires covered with PVC tubing
 - 2) Double insulated wires
 - 3) High voltage leads
- D.** Use specified insulating materials for hazardous live parts. Note especially:
 - 1) Insulation tape
 - 2) PVC tubing
 - 3) Spacers
 - 4) Insulators for transistors
- E.** When replacing AC primary side components (transformers, power cord, etc.), wrap ends of wires securely about the terminals before soldering.
- F.** Observe that the wires do not contact heat producing parts (heatsinks, oxide metal film resistors, fusible resistors, etc.).
- G.** Check that replaced wires do not contact sharp edges or pointed parts.
- H.** When a power cord has been replaced, check that 5 - 6 kg of force in any direction will not loosen it.
- I.** Also check areas surrounding repaired locations.
- J.** Use care that foreign objects (screws, solder droplets, etc.) do not remain inside the set.
- K.** Crimp type wire connector
The power transformer uses crimp type connectors which connect the power cord and the primary side of the transformer. When replacing the transformer, follow these steps carefully and precisely to prevent shock hazards.
Replacement procedure
 - 1) Remove the old connector by cutting the wires at a point close to the connector.
Important: Do not re-use a connector. (Discard it.)
 - 2) Strip about 15 mm of the insulation from the ends of the wires. If the wires are stranded, twist the strands to avoid frayed conductors.
 - 3) Align the lengths of the wires to be connected. Insert the wires fully into the connector.
 - 4) Use a crimping tool to crimp the metal sleeve at its center. Be sure to crimp fully to the complete closure of the tool.
- L.** When connecting or disconnecting the internal connectors, first, disconnect the AC plug from the AC outlet.

Safety Check after Servicing

Examine the area surrounding the repaired location for damage or deterioration. Observe that screws, parts, and wires have been returned to their original positions. Afterwards, do the following tests and confirm the specified values to verify compliance with safety standards.

1. Clearance Distance

When replacing primary circuit components, confirm specified clearance distance (d) and (d') between soldered terminals, and between terminals and surrounding metallic parts. (See Fig. 1)

Table 1 : Ratings for selected area

AC Line Voltage	Clearance Distance (d) (d')
110 to 240 V	$\geq 3\text{mm}(d)$ $\geq 6\text{mm}(d')$

Note: This table is unofficial and for reference only.
Be sure to confirm the precise values.

2. Leakage Current Test

Confirm the specified (or lower) leakage current between B (earth ground, power cord plug prongs) and externally exposed accessible parts (RF terminals, antenna terminals, video and audio input and output terminals, microphone jacks, earphone jacks, etc.) is lower than or equal to the specified value in the table below.

Measuring Method (Power ON) :

Insert load Z between B (earth ground, power cord plug prongs) and exposed accessible parts. Use an AC voltmeter to measure across the terminals of load Z. See Fig. 2 and the following table.

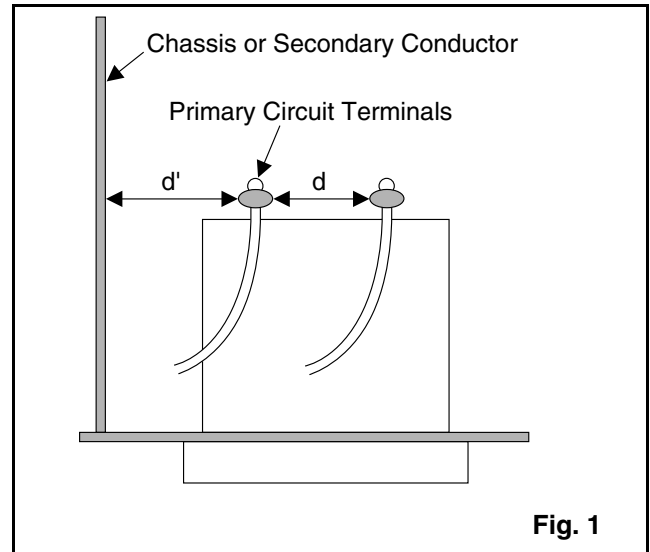

Fig. 1

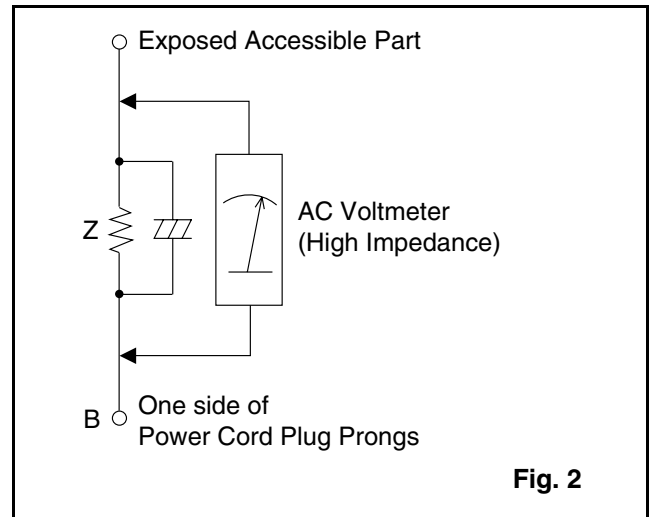

Fig. 2

Table 2: Leakage current ratings for selected areas

AC Line Voltage	Load Z	Leakage Current (i)	One side of power cord plug prongs (B) to:
110 to 240 V	2k Ω RES. Connected in parallel	$i \leq 0.7\text{mA AC Peak}$ $i \leq 2\text{mA DC}$	RF or Antenna terminals
	50k Ω RES. Connected in parallel	$i \leq 0.7\text{mA AC Peak}$ $i \leq 2\text{mA DC}$	A/V Input, Output

Note: This table is unofficial and for reference only. Be sure to confirm the precise values.

STANDARD NOTES FOR SERVICING

Circuit Board Indications

- a. The output pin of the 3 pin Regulator ICs is indicated as shown.

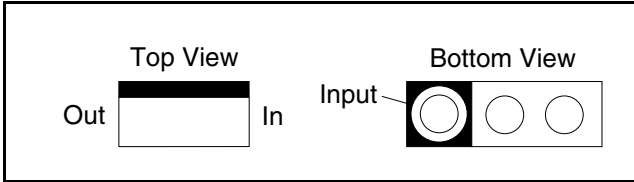

- b. For other ICs, pin 1 and every fifth pin are indicated as shown.

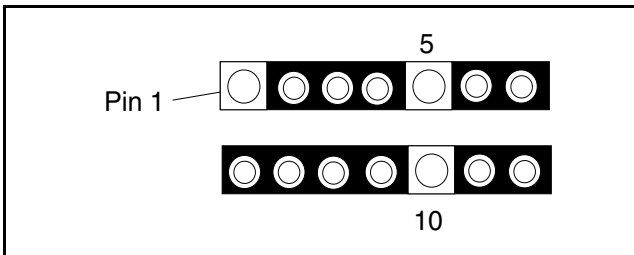

- c. The 1st pin of every male connector is indicated as shown.

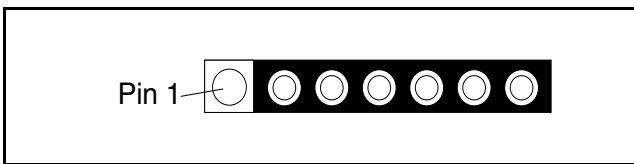

Instructions for Connectors

1. When you connect or disconnect the FFC (Flexible Foil Connector) cable, be sure to first disconnect the AC cord.
2. FFC (Flexible Foil Connector) cable should be inserted parallel into the connector, not at an angle.

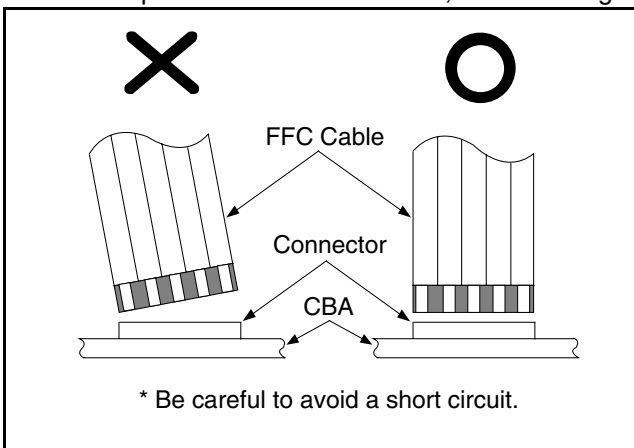

How to Remove / Install Flat Pack-IC

1. Removal

With Hot-Air Flat Pack-IC Desoldering Machine:

- (1) Prepare the hot-air flat pack-IC desoldering machine, then apply hot air to the Flat Pack-IC (about 5 to 6 seconds). (Fig. S-1-1)

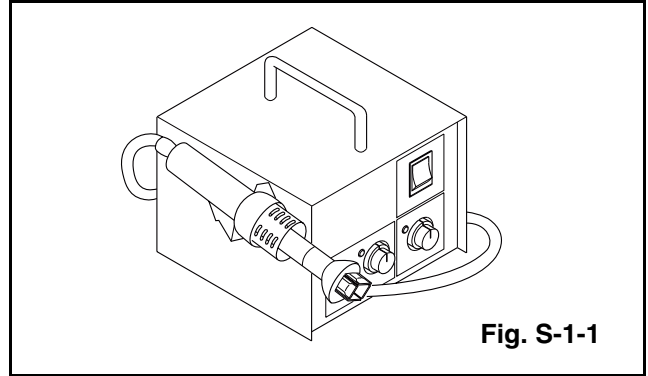

- (2) Remove the flat pack-IC with tweezers while applying the hot air.
- (3) Bottom of the flat pack-IC is fixed with glue to the CBA; when removing entire flat pack-IC, first apply soldering iron to center of the flat pack-IC and heat up. Then remove (glue will be melted). (Fig. S-1-6)
- (4) Release the flat pack-IC from the CBA using tweezers. (Fig. S-1-6)

Caution:

1. Do not supply hot air to the chip parts around the flat pack-IC for over 6 seconds because damage to the chip parts may occur. Put masking tape around the flat pack-IC to protect other parts from damage. (Fig. S-1-2)
2. The flat pack-IC on the CBA is affixed with glue, so be careful not to break or damage the foil of each pin or the solder lands under the IC when removing it.

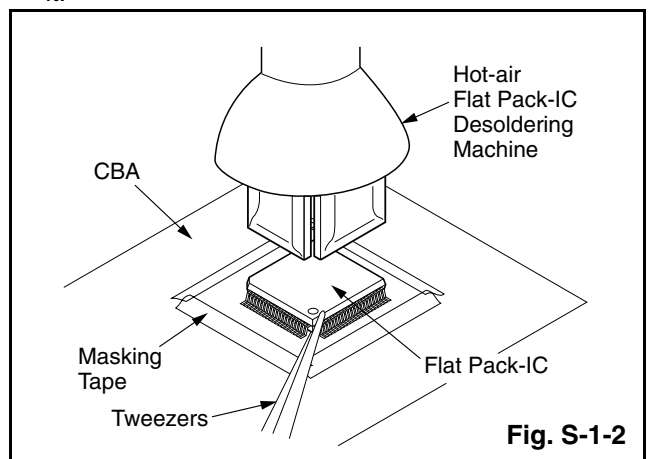

With Soldering Iron:

- (1) Using desoldering braid, remove the solder from all pins of the flat pack-IC. When you use solder flux which is applied to all pins of the flat pack-IC, you can remove it easily. (Fig. S-1-3)

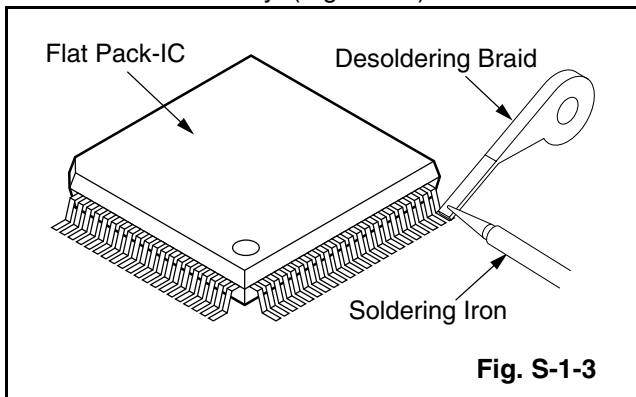

- (2) Lift each lead of the flat pack-IC upward one by one, using a sharp pin or wire to which solder will not adhere (iron wire). When heating the pins, use a fine tip soldering iron or a hot air desoldering machine. (Fig. S-1-4)

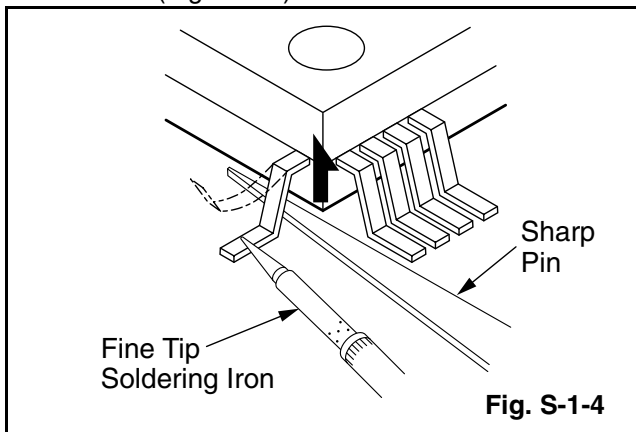

- (3) Bottom of the flat pack-IC is fixed with glue to the CBA; when removing entire flat pack-IC, first apply soldering iron to center of the flat pack-IC and heat up. Then remove (glue will be melted). (Fig. S-1-6)
- (4) Release the flat pack-IC from the CBA using tweezers. (Fig. S-1-6)

With Iron Wire:

- (1) Using desoldering braid, remove the solder from all pins of the flat pack-IC. When you use solder flux which is applied to all pins of the flat pack-IC, you can remove it easily. (Fig. S-1-3)
- (2) Affix the wire to a workbench or solid mounting point, as shown in Fig. S-1-5.
- (3) While heating the pins using a fine tip soldering iron or hot air blower, pull up the wire as the solder melts so as to lift the IC leads from the CBA contact pads as shown in Fig. S-1-5

- (4) Bottom of the flat pack-IC is fixed with glue to the CBA; when removing entire flat pack-IC, first apply soldering iron to center of the flat pack-IC and heat up. Then remove (glue will be melted). (Fig. S-1-6)
- (5) Release the flat pack-IC from the CBA using tweezers. (Fig. S-1-6)

Note:

When using a soldering iron, care must be taken to ensure that the flat pack-IC is not being held by glue. When the flat pack-IC is removed from the CBA, handle it gently because it may be damaged if force is applied.

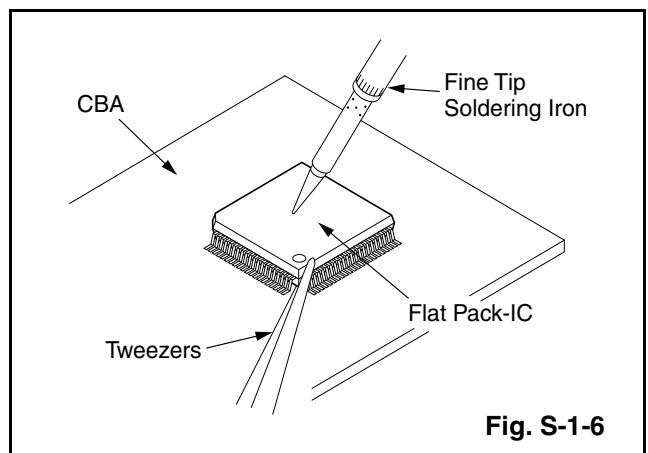
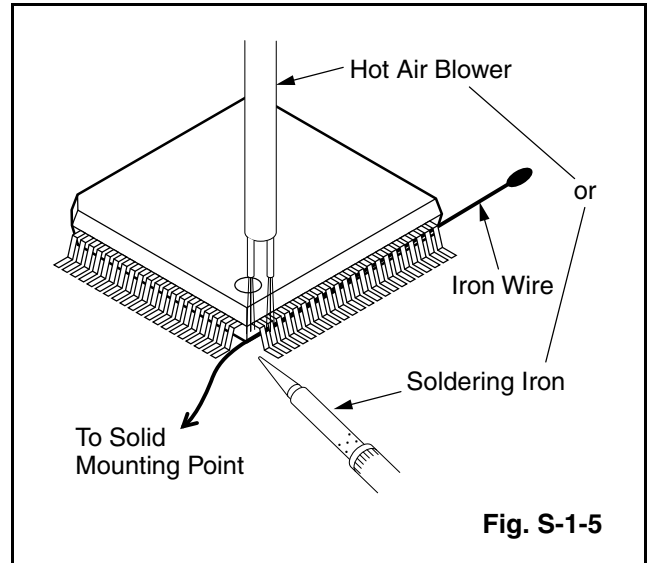

2. Installation

- (1) Using desoldering braid, remove the solder from the foil of each pin of the flat pack-IC on the CBA so you can install a replacement flat pack-IC more easily.
- (2) The "●" mark on the flat pack-IC indicates pin 1. (See Fig. S-1-7.) Be sure this mark matches the 1 on the PCB when positioning for installation. Then presolder the four corners of the flat pack-IC. (See Fig. S-1-8.)
- (3) Solder all pins of the flat pack-IC. Be sure that none of the pins have solder bridges.

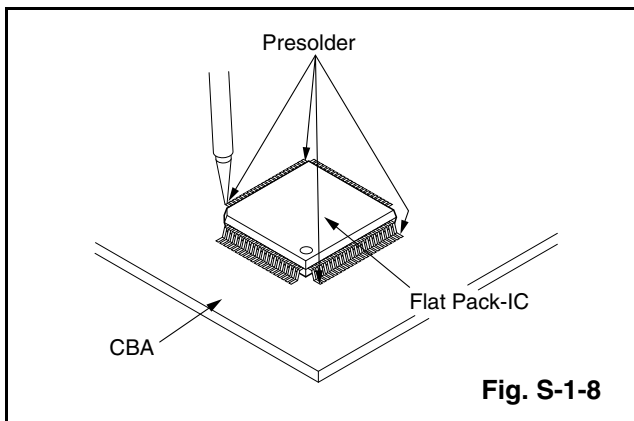
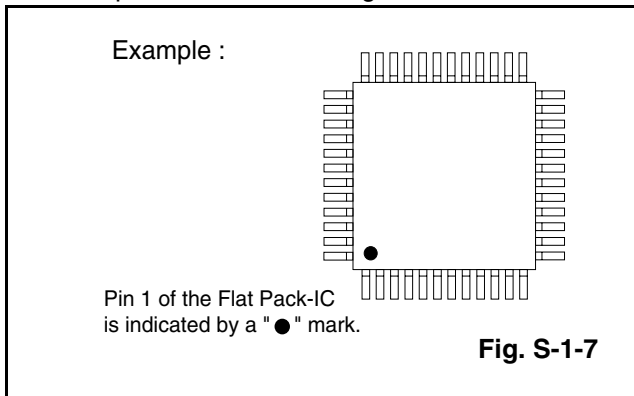

Instructions for Handling Semi-conductors

Electrostatic breakdown of the semi-conductors may occur due to a potential difference caused by electrostatic charge during unpacking or repair work.

1. Ground for Human Body

Be sure to wear a grounding band ($1M\Omega$) that is properly grounded to remove any static electricity that may be charged on the body.

2. Ground for Workbench

Be sure to place a conductive sheet or copper plate with proper grounding ($1M\Omega$) on the workbench or other surface, where the semi-conductors are to be placed. Because the static electricity charge on clothing will not escape through the body grounding band, be careful to avoid contacting semi-conductors with your clothing.

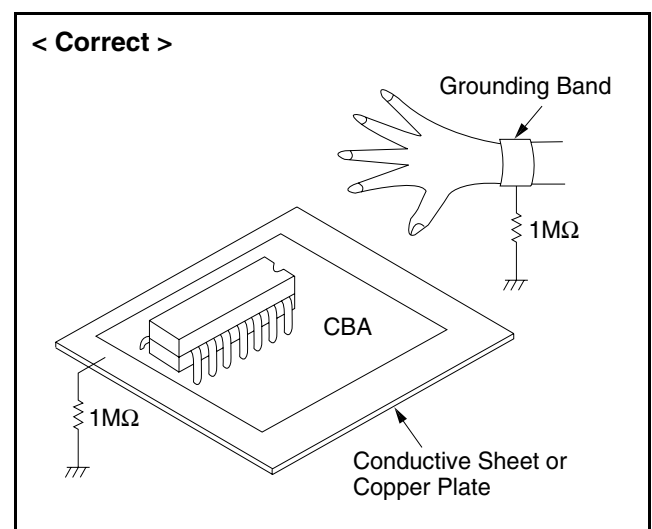
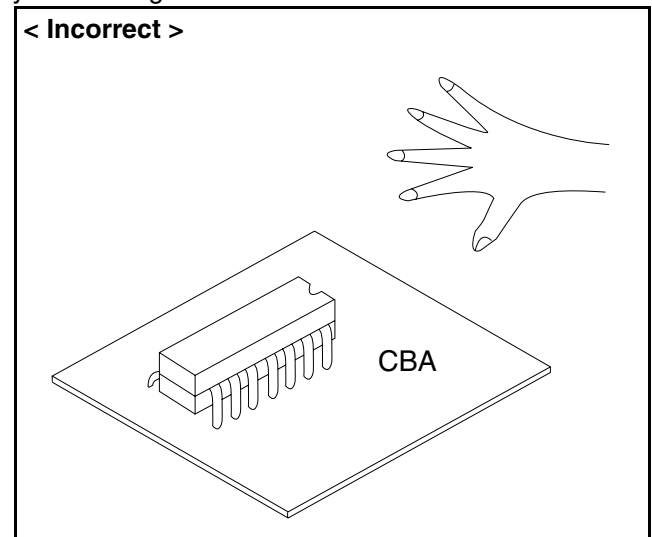

PREPARATION FOR SERVICING

How to Enter the Service Mode

About Optical Sensors

Caution:

An optical sensor system is used for the Tape Start and End Sensors on this equipment. Carefully read and follow the instructions below. Otherwise the unit may operate erratically.

What to do for preparation

Insert a tape into the Deck Mechanism Assembly and press the PLAY button. The tape will be loaded into the Deck Mechanism Assembly. Make sure the power is on, TP501 (SENSOR INHIBITION) to GND. This will stop the function of Tape Start Sensor, Tape End Sensor and Reel Sensors. (If these TPs are connected before plugging in the unit, the function of the sensors will stay valid.) See Fig. 1.

Note: Because the Tape End Sensors are inactive, do not run a tape all the way to the start or the end of the tape to avoid tape damage.

About REC-Safety Switch

Caution:

The REC-Safety Switch is directly mounted on the Main CBA. When the Deck Mechanism Assembly is removed from the Main CBA for servicing, this switch does not work automatically.

What to do for preparation

In order to record, press the Rec button while pushing REC-SAFETY SW on the Main CBA. See Fig. 1.

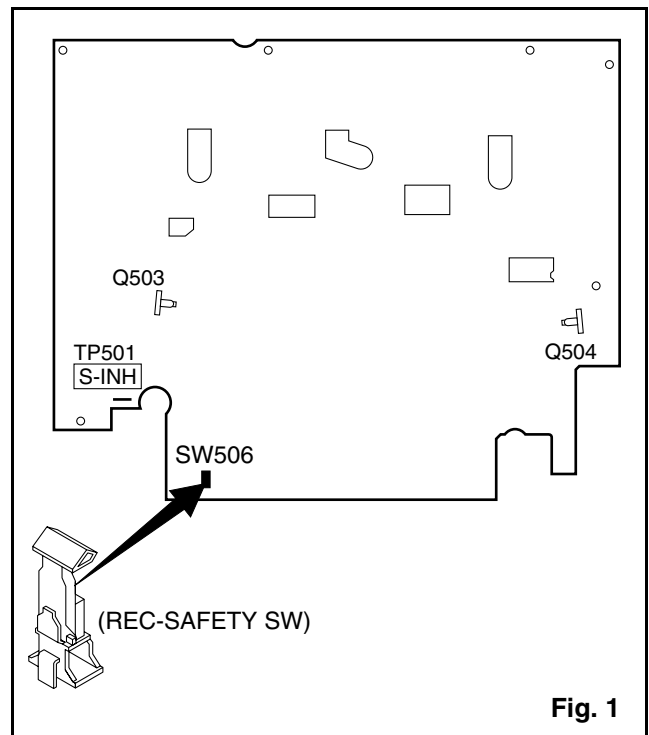
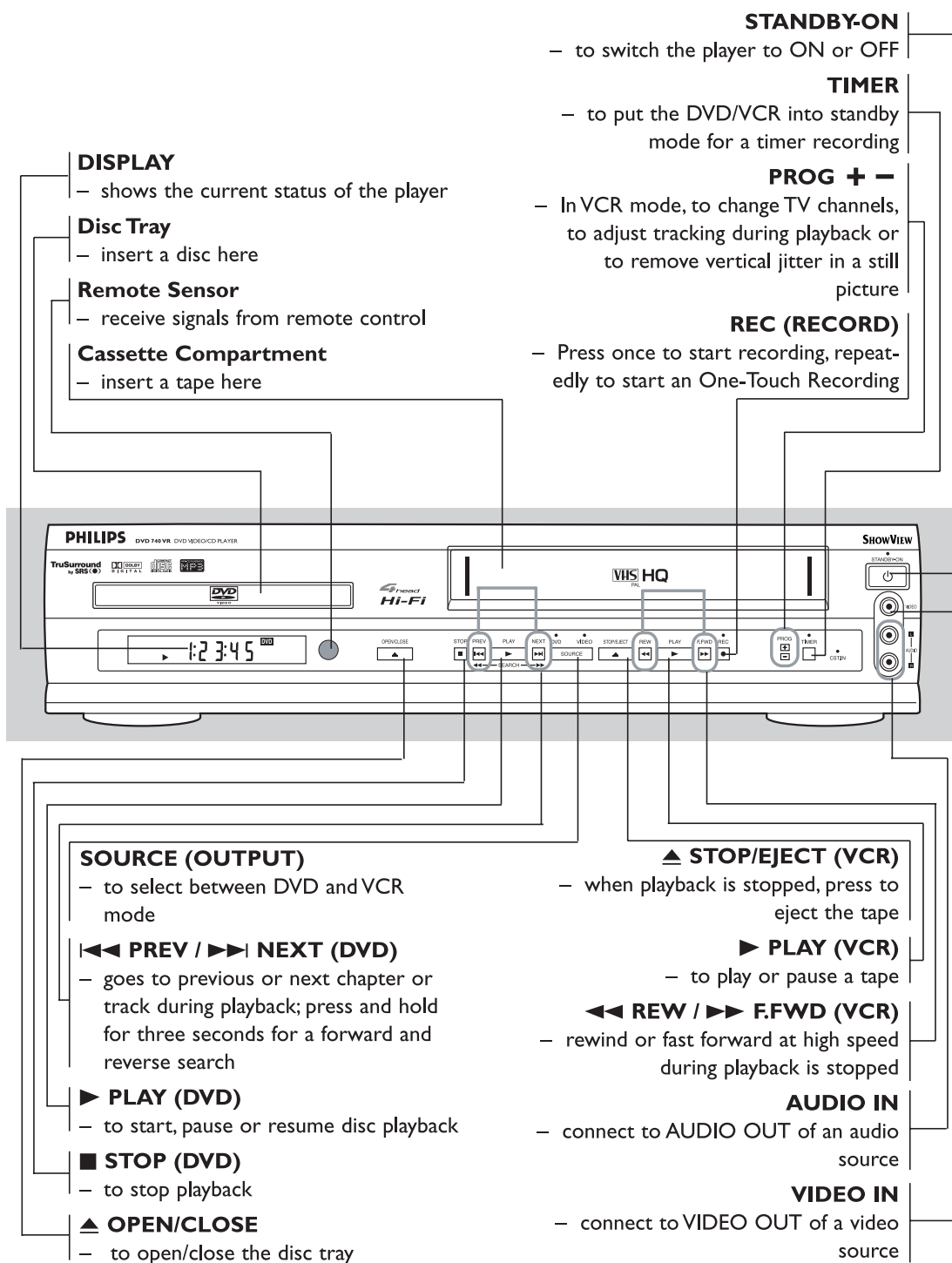

Fig. 1

OPERATING CONTROLS AND FUNCTIONS

[DVD740VR/001]

Front Panel



Display front Panel

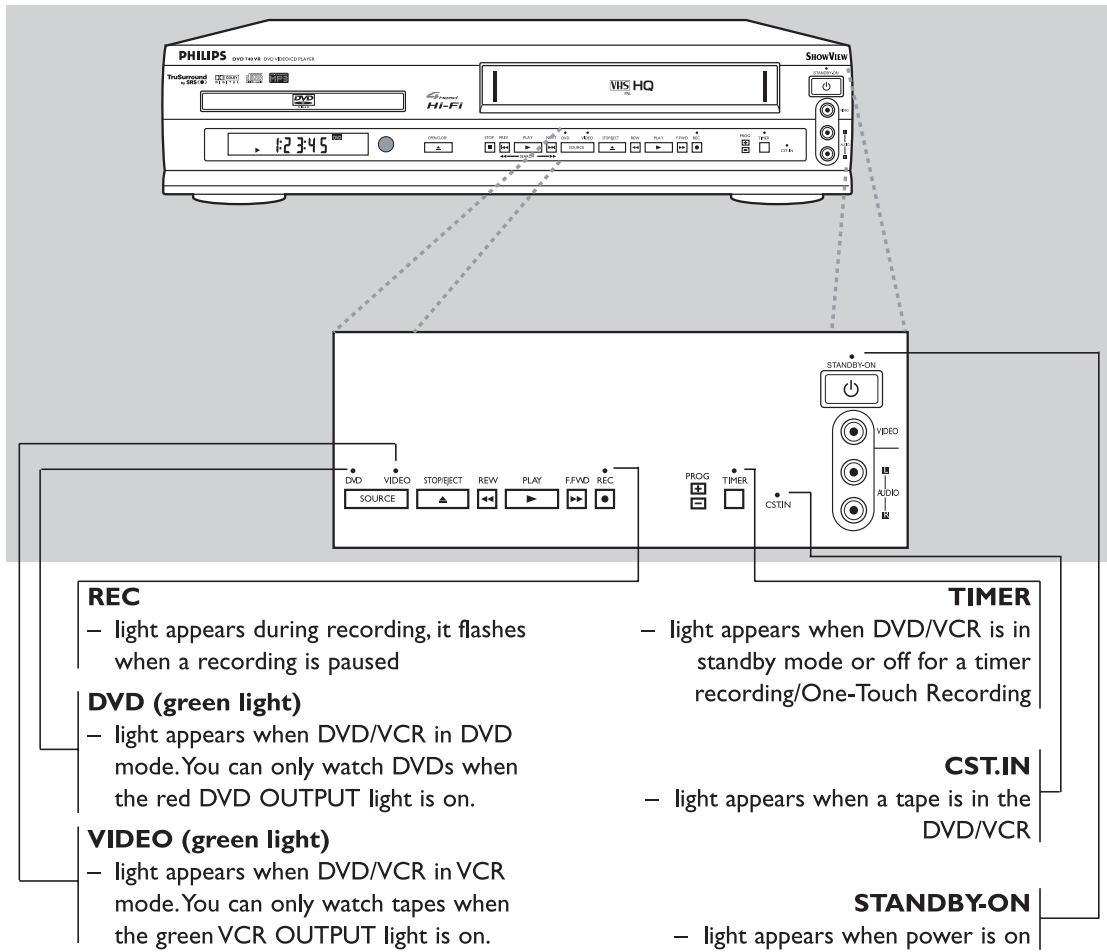

REC

- light appears during recording, it flashes when a recording is paused

DVD (green light)

- light appears when DVD/VCR in DVD mode. You can only watch DVDs when the red DVD OUTPUT light is on.

VIDEO (green light)

- light appears when DVD/VCR in VCR mode. You can only watch tapes when the green VCR OUTPUT light is on.

TIMER

- light appears when DVD/VCR is in standby mode or off for a timer recording/One-Touch Recording

CST.IN

- light appears when a tape is in the DVD/VCR

STANDBY-ON

- light appears when power is on

Display Message

P - 00	Power is turning on.
- - - -	Appears after the disc tray closes if the tray is empty, if there is an error reading the disc, or if an unacceptable disc is installed.
OPEN	Tray is opening or is open.
CLOSE	Tray is closing. This also may appear as the Player tries to load a Disc.
Load	Disc is loading.
P - 0FF	Power is turning off.

Rear Panel

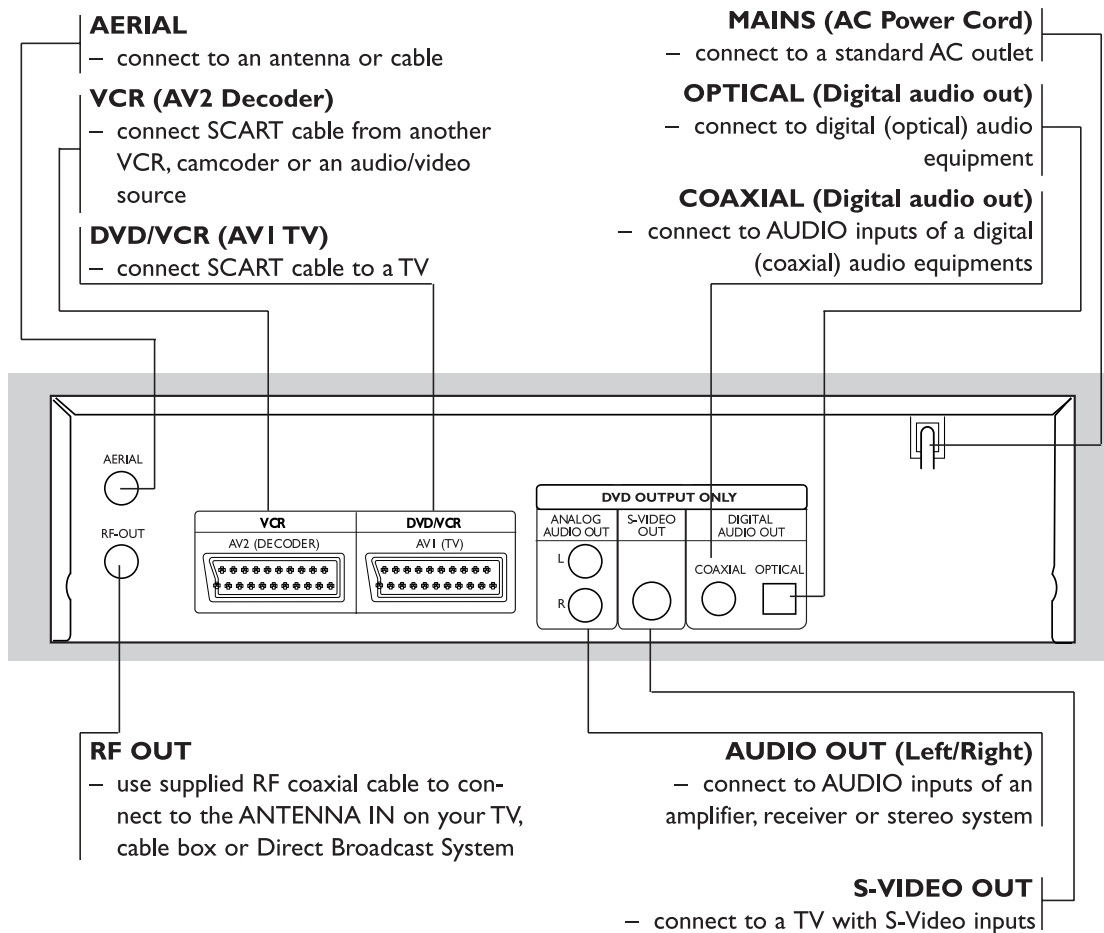

Caution: Do not touch the inner pins of the jacks on the rear panel. Electrostatic discharge may cause permanent damage to the unit.

Remote Control

- to put the DVD/VCR into standby mode for a timer recording
- TIMER SET**
- SETUP**
 - to access or remove the DVD setup menu (DVD)
- AUDIO**
 - to choose audio languages or sound modes (DVD)
 - to choose sound modes (VCR)
- SUBTITLE**
 - subtitle language DVD selector (DVD)
- ANGLE**
 - select DVD camera angle (DVD)
- SKIP/P (|◀◀| + |▶▶| –)**
 - to skip chapter/tracks (DVD)
 - to change TV channels (VCR)
- C.RESET/CLEAR**
 - to reset the setting (DVD)
 - to reset the counter (VCR)
- DVD**
 - press before using the remote control for DVD features
- DISPLAY**
 - to access or remove the display screen during DVD or Audio CD playback(DVD)
 - to access or remove VCR's on-screen status display(VCR)
- VCR**
 - press before using the remote control for VCR features
- DISC MENU**
 - to display the menu of the DVD disc or to access VCR menu
- ◀ ▶ ▲ ▼
 - (left/right/up/down) select an item in the menu (DVD)
- 0-9 numerical key pad/+10**
 - select numbered items in a menu (DVD)
 - use +10 button to enter number 10 and above (DVD)
- DAILY/WEEKLY**
 - Press to select once, daily, everyday, or weekly when you programme the automatic timer recording using the ShowView system (VCR)
- ZOOM**
 - enlarge DVD video image (DVD)
- SEARCH MODE/QUICK-FIND**
 - to access or remove search display (DVD)
 - to skip to the beginning of next programme(VCR)
- INDEX SEARCH**
 - to fast forward or rewind the tape at index number (VCR)
- TIME SEARCH**
 - to fast forward or rewind the tape at specific length of time (VCR)

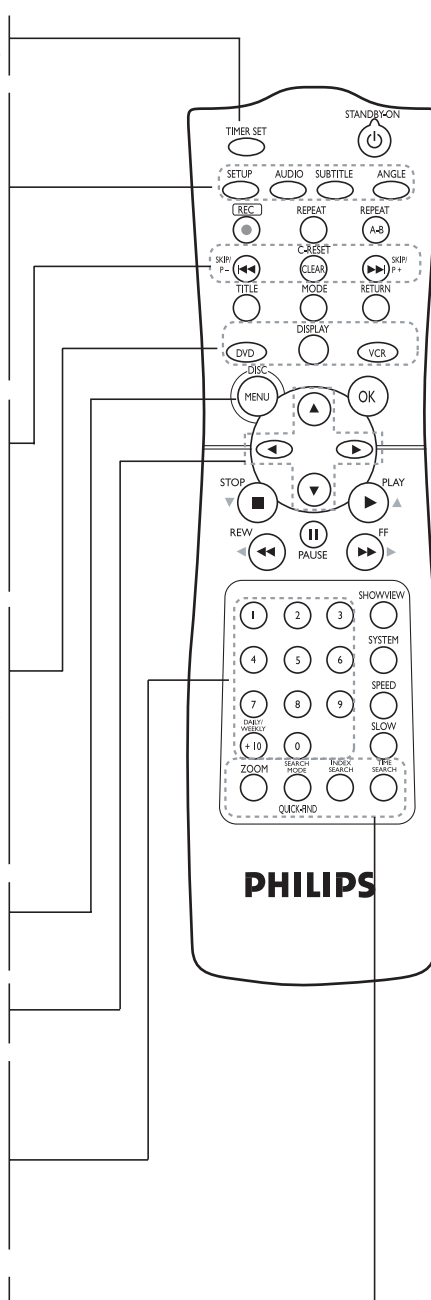

Remote Control (cont'd)

- STANDBY-ON** 
- switch DVD/VCR ON or OFF
- REC**
- press once to start recording or repeatedly to start (VCR)
- REPEAT**
- repeat chapter, track, title, disc (DVD)
- REPEAT (A-B)**
- repeat a specific segment (DVD)
- TITLE**
- to display title menu of a disc (DVD)
- MODE**
- to set up programmed or random playback (Audio CD) (DVD)
- RETURN**
- to return previous or remove setup menu (DVD)
- OK**
- acknowledge menu selection (DVD)
- STOP (■ / ▼)**
- to stop a DVD disc playback (DVD)
- to stop playback, recording or to select an item in the VCR menu (VCR)
- PLAY (▶ / ▲)**
- to start a DVD disc playback (DVD)
- to start a tape playback or to select an item in the VCR menu (VCR)
- REW (◀◀ / ◀)**
- to view DVD picture in fast reverse motion (DVD)
- to rewind the tape (VCR)
- PAUSE (||)**
- pause playback temporarily / frame-by-frame playback (DVD)
- pause playback and during recording temporarily (VCR)
- FF (▶▶ / ▶)**
- to view DVD picture in fast forward motion (DVD)
- to fast forward the tape (VCR)
- SHOWVIEW**
- to programme timer recording with the SHOWVIEW system (VCR)
- SYSTEM**
- Doesn't work in this model
- SPEED**
- to select VCR's recording speed (SP or LP) (VCR)
- SLOW**
- to view tape playback in slow motion (VCR)

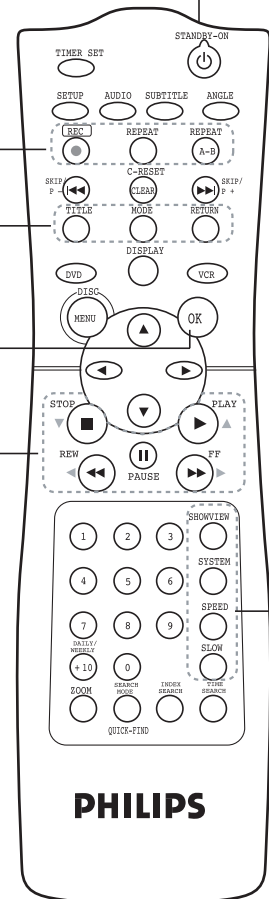

Functional Overview

Front Panel

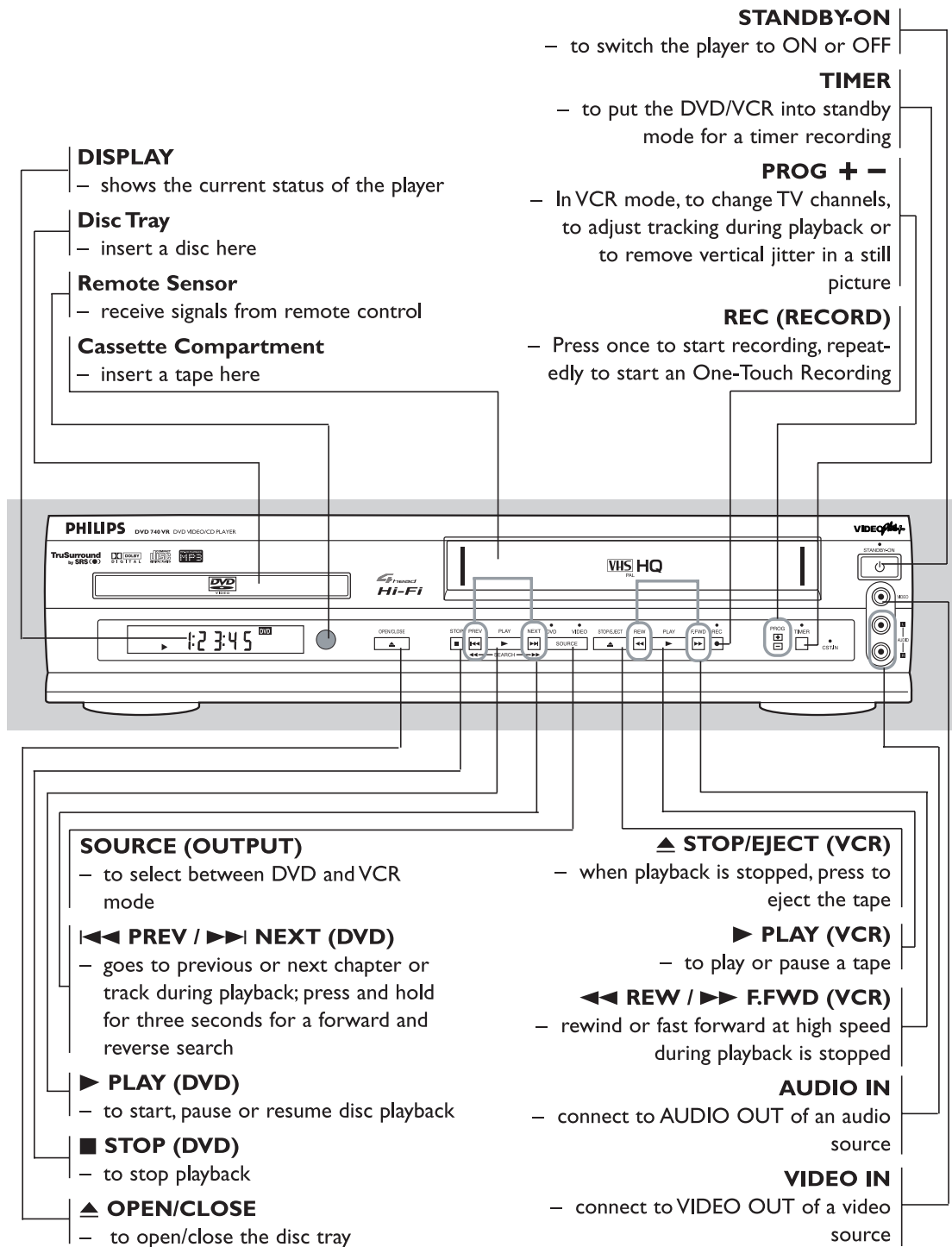

Display front Panel

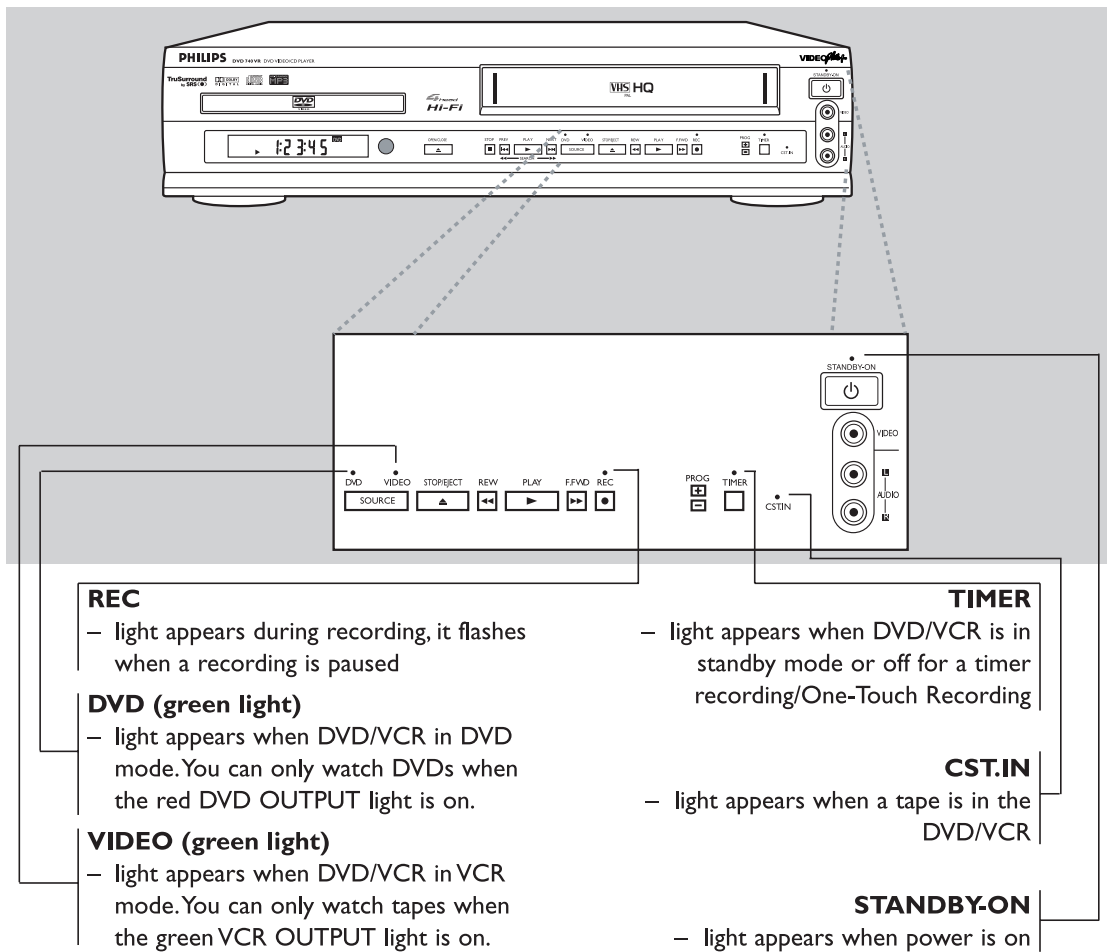

REC

- light appears during recording, it flashes when a recording is paused

DVD (green light)

- light appears when DVD/VCR in DVD mode. You can only watch DVDs when the red DVD OUTPUT light is on.

VIDEO (green light)

- light appears when DVD/VCR in VCR mode. You can only watch tapes when the green VCR OUTPUT light is on.

TIMER

- light appears when DVD/VCR is in standby mode or off for a timer recording/One-Touch Recording

CST.IN

- light appears when a tape is in the DVD/VCR

STANDBY-ON

- light appears when power is on

Display Message

P - 00	Power is turning on.
- - - -	Appears after the disc tray closes if the tray is empty, if there is an error reading the disc, or if an unacceptable disc is installed.
OPEN	Tray is opening or is open.
CLOSE	Tray is closing. This also may appear as the Player tries to load a Disc.
Load	Disc is loading.
P - 0FF	Power is turning off.

Rear Panel

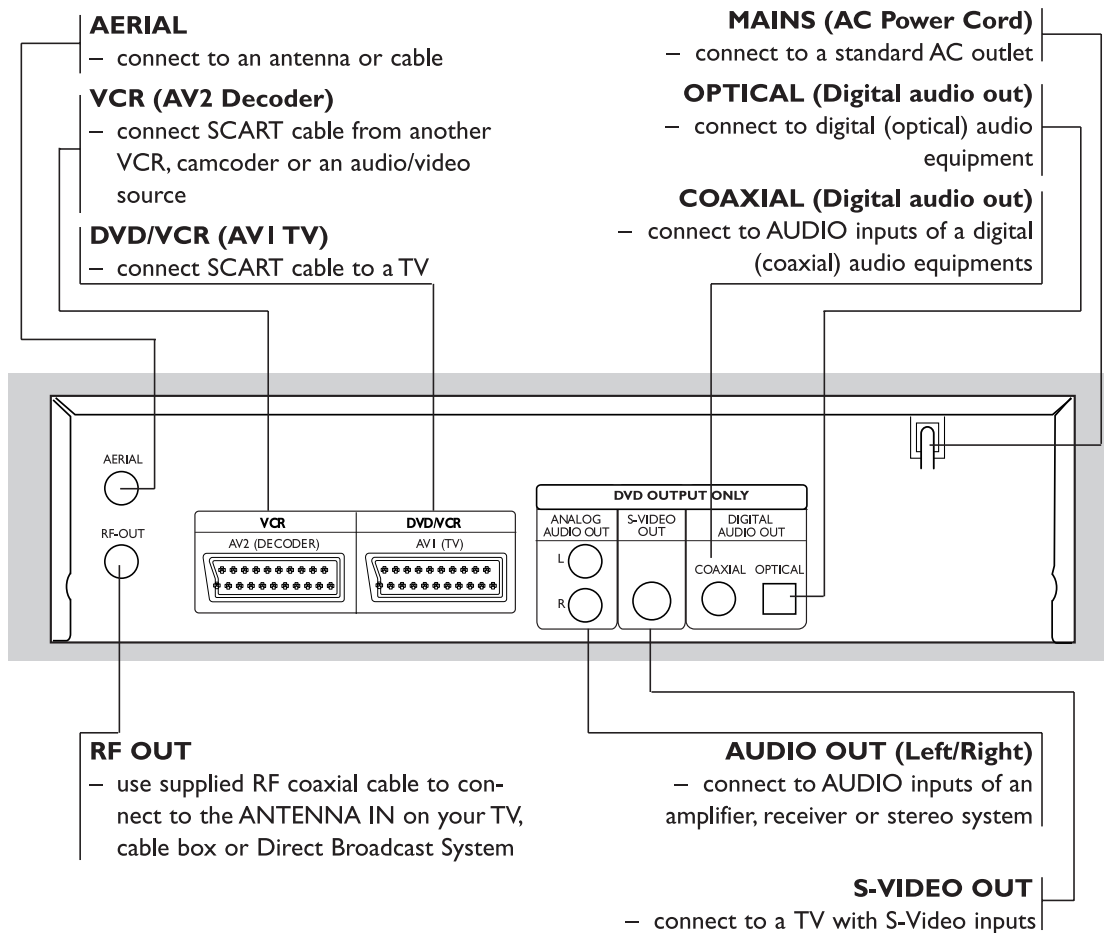

Caution: Do not touch the inner pins of the jacks on the rear panel. Electrostatic discharge may cause permanent damage to the unit.

Remote Control

- to put the DVD/VCR into standby mode for a timer recording

TIMER SET

SETUP

- to access or remove the DVD setup menu (DVD)

AUDIO

- to choose audio languages or sound modes (DVD)
 - to choose sound modes (VCR)

SUBTITLE

- subtitle language DVD selector (DVD)

ANGLE

- select DVD camera angle (DVD)

SKIP/P (◀◀/▶▶/–)

- to skip chapter/tracks (DVD)
- to change TV channels (VCR)

C.RESET/CLEAR

- to reset the setting (DVD)
- to reset the counter (VCR)

DVD

- press before using the remote control for DVD features

DISPLAY

- to access or remove the display screen during DVD or Audio CD playback (DVD)
- to access or remove VCR's on-screen status display (VCR)

VCR

- press before using the remote control for VCR features

DISC MENU

- to display the menu of the DVD disc or to access VCR menu



- (left/right/up/down) select an item in the menu (DVD)

0-9 numerical key pad/+10

- select numbered items in a menu (DVD)
- use +10 button to enter number 10 and above (DVD)

DAILY/WEEKLY

- Press to select once, daily, everyday, or weekly when you programme the automatic timer recording using the VIDEO Plus+ system (VCR)

ZOOM

- enlarge DVD video image (DVD)

SEARCH MODE/QUICK-FIND

- to access or remove search display (DVD)
- to skip to the beginning of next programme (VCR)

INDEX SEARCH

- to fast forward or rewind the tape at index number (VCR)

TIME SEARCH

- to fast forward or rewind the tape at specific length of time (VCR)

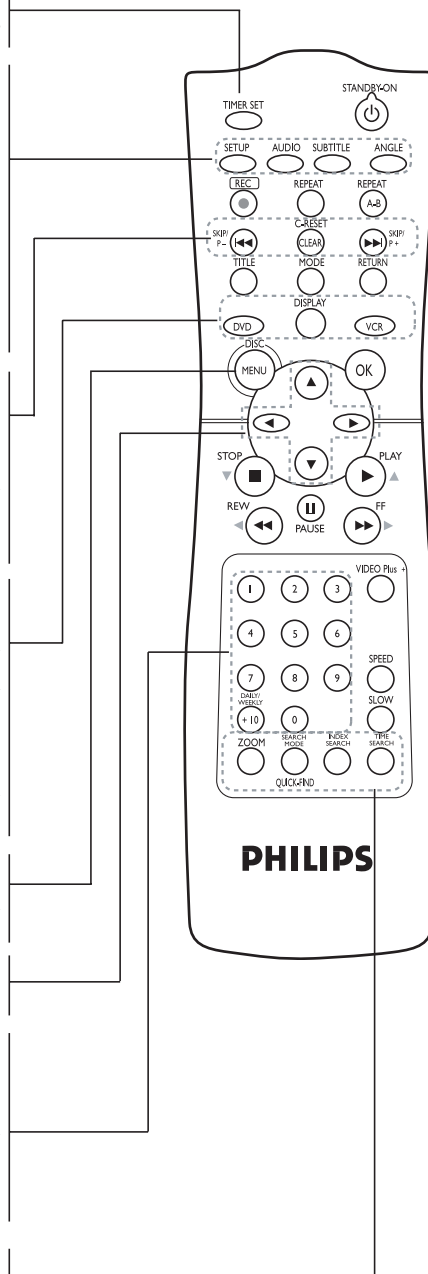

Remote Control (cont'd)

- STANDBY-ON** 
- switch DVD/VCR ON or OFF
- REC**
- press once to start recording or repeatedly to start (VCR)
- REPEAT**
- repeat chapter, track, title, disc (DVD)
- REPEAT (A-B)**
- repeat a specific segment (DVD)
- TITLE**
- to display title menu of a disc (DVD)
- MODE**
- to set up programmed or random playback (Audio CD) (DVD)
- RETURN**
- to return previous or remove setup menu (DVD)
- OK**
- acknowledge menu selection (DVD)
- STOP (■ / ▼)**
- to stop a DVD disc playback (DVD)
- to stop playback, recording or to select an item in the VCR menu (VCR)
- PLAY (▶ / ▲)**
- to start a DVD disc playback (DVD)
- to start a tape playback or to select an item in the VCR menu (VCR)
- REW (◀◀ / ◀)**
- to view DVD picture in fast reverse motion (DVD)
- to rewind the tape (VCR)
- PAUSE (||)**
- pause playback temporarily / frame-by-frame playback (DVD)
- pause playback and during recording temporarily (VCR)
- FF (▶▶ / ▶)**
- to view DVD picture in fast forward motion (DVD)
- to fast forward the tape (VCR)
- VIDEO Plus+**
- to programme timer recording with the VIDEO Plus+ system (VCR)
- SPEED**
- to select VCR's recording speed (SP or LP) (VCR)
- SLOW**
- to view tape playback in slow motion (VCR)

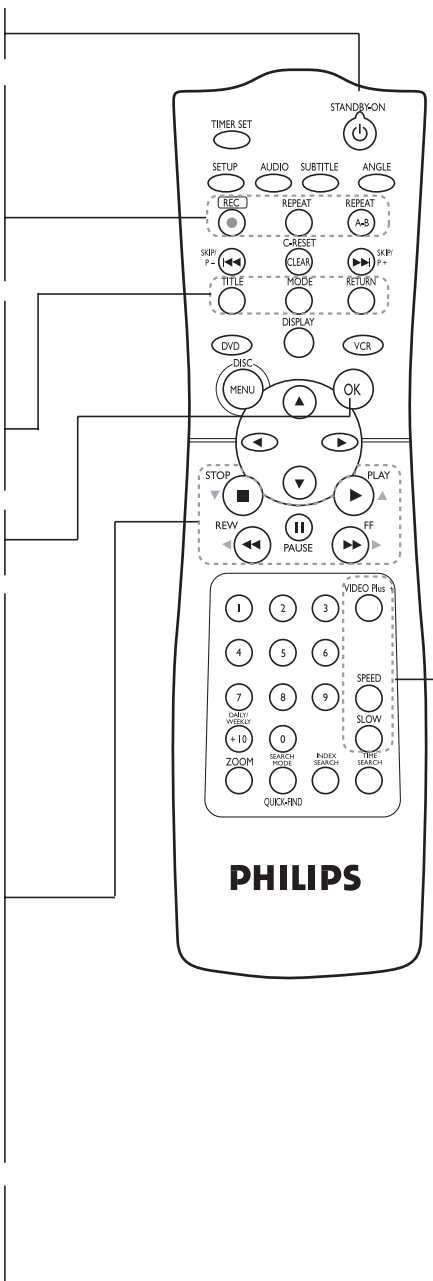

SIGNAL NAME ABBREVIATIONS

Signal Name	Function
8POUT-1	SCART 1 8Pin Output Control Signal
8POUT-2	SCART 2 8Pin Output Control Signal
A-COM	Audio Head Common
A-MODE	Hi-Fi Tape Detection Signal
A-MUTE-H	Audio Mute Control Signal (Mute = "H")
A-IN(L)-F	Audio Signal Input (L)
A-IN(R)-F	Audio Signal Input (R)
A-OUT(L)-F	Audio Signal Output (L)
A-OUT(R)-F	Audio Signal Output (R)
A-PB/REC	Normal Audio Play Back/Record Signal
AE-H	Audio Erase Head
AFC	Automatic Frequency Control Signal
AGC	IF AGC Control Signal
AL+15V/+12V	Always +15V/+12V with AC Plug Connected
AL+5V	Always +5V with AC Plug Connected
AL+9V	Always +9V with AC Plug Connected
AL+12V	Always +12V with AC Plug Connected
AL-30V	Always -30V with AC Plug Connected
AMPC	CTL AMP Connected Terminal
AMPV _{cc}	AMPV _{cc}
AMPVREF _{IN}	V-Ref for CTL AMP
AMPV _{ss}	AMPV _{ss} (GND)
AV _{cc}	A/D Converter Power Input/ Standard Voltage Input
C	C Terminal
C-CONT	Capstan Motor Control Signal
C-F/R	Capstan Motor FWD/REV Control Signal (FWD="L"/REV="H")
C-FG	Capstan Motor Rotation Detection Pulse
C-POWER-SW	Capstan Power Switching Pulse

Signal Name	Function
C-ROTA	Color Phase Rotary Changeover Signal
C-SYNC	Composite Synchronized Pulse
CAS LED	"CASSETTE" LED Signal Output
CLKSEL	Clock Select (GND)
CTL (+)	Playback/Record Control Signal(+)
CTL (-)	Playback/Record Control Signal (-)
CTLAMPout	To Monitor for CTL AMP Output
D-CONT	Drum Motor Control Signal
D-FG	Drum Motor Rotation Detection Pulse
D-PG	Drum Motor Pulse Generator
D-REC-H	Delayed Record Signal
D-V- SYNC	Dummy V-sync Output
DAVN-L	VPS/PDC Data Receive = "L"
DRV-CLK	LED Clock Driver IC Control Clock
DRV-DATA	LED Clock Driver IC Control Data
DRV-STB	LED Clock Driver IC Chip Select Signal
DVD LED	"DVD" LED Signal Output
DVD-8PIN-IN	SCART 8Pin DVD Input Control Signal
DVD-P-ON+3.3V	+3.3V at DVD Power-On Signal
DVD-P-ON+5V	+5V at DVD Power-On Signal
DVD-P-ON+12V	+12V at DVD Power-On Signal
DVD-POWER	DVD Power Control Signal
DVD-POWER-MONITOR	DVD Power Monitor Signal (P-off="H", P-on="L")
DVD-B-OUT	DVD Component Video Signal (blue)
DVD-G-OUT	DVD Component Video Signal (green)
DVD-R-OUT	DVD Component Video Signal (red)
END-S	Tape End Position Detect Signal
FE-H GND	Ground for Full Erase Head
FF/REW-L	CTL Amp Gain Switching Signal (FF/REW="L")
FSC-IN [4.43MHz]	4.43MHz Clock Input

Signal Name	Function
FTV-IN	Comparator Input of Video Signal for Follow TV
H-A-COMP	Head Amp Comparator Signal
H-A-SW	Video Head Amp Switching Pulse
Hi-Fi-A (L)	Hi-Fi Audio Head (L)
Hi-Fi-A (R)	Hi-Fi Audio Head (R)
Hi-Fi-COM	Hi-Fi Audio Head Common
Hi-Fi-H-SW	Hi-Fi Audio Head Switching Pulse
HLF	LPF Connected Terminal (Slicer)
IIC-BUS- SCL	IIC BUS Control Clock
IIC-BUS- SDA	IIC BUS Control Data
JK1-8P-OUT-1	SCART 1 8Pin Output Control Signal
JK1-8P-OUT-2	SCART 2 8Pin Output Control Signal
KEY-1	Key Scan Input Signal 1
KEY-2	Key Scan Input Signal 2
LD-SW	Deck Mode Position Detector Signal
LM-FWD/REV	Loading Motor Control Signal
MOD-A	Modulator Audio Output Signal
MOD-V	Modulator Video Output Signal
N-A-PB	Normal Audio Playback
N-A-REC	Normal Audio Recording
OSCIN	Clock Input for letter size
OSCOU	Clock Output for letter size
OSD-V-IN	OSD Video Signal Input
OSD-V-OUT	OSD Video Signal Output
OSDVss	OSDVss
OUTPUT-SELECT	Output Select
P-DOWN-L	Power Voltage Down Detector Signal
P-ON+44V	+44V at Power-On Signal
P-ON+5V	+5V at Power-On Signal
P-ON+9V	+9V at Power-On Signal
P-ON-H	Power On Signal at High
PG-DELAY	Video Head Switching Pulse Signal Adjusted Voltage
PG/LP	PG/LP
POW-SAF	P-ON Power Detection Input Signal

Signal Name	Function
REC LED	"REC" LED Signal Output
REC-SAF-SW	Recording Safety SW Detect (With Record tab="L"/ With out Record tab="H")
REMOTE	Remote Control Sensor
RESET	System Reset Signal (Reset="L")
RF-SW	Video Head Switching Pulse
RGB-THROUGH	SCART 2 RGB Through Control Signal
S-REEL	Supply Reel Rotation Signal
SC2-IN	Input Signal from Pin 8 of SCART2
ST-S	Tape Start Position Detector Signal
T-REEL	Take Up Reel Rotation Signal
TIMER LED	"TIMER" LED Signal Output
TIMER+5V	+5V at Timer
TU-AUDIO	Tuner Audio Input Signal
TU-VIDEO	Tuner Video Input Signal
V-ENV	Video Envelope Comparator Signal
Vcc	Vcc
VCR LED	"VCR" LED Signal Output
V-IN	Video Signal Input
V-OUT	Video Signal Output
VIDEO-IN	Video Signal Input
VIDEO-OUT	Video Signal Output
Vss	Vss(GND)
X-IN	Main Clock Input
X-OUT	Main Clock Input
XC-IN	Sub Clock
XC-OUT	Sub Clock

CABINET DISASSEMBLY INSTRUCTIONS

1. Disassembly Flowchart

This flowchart indicates the disassembly steps to gain access to item(s) to be serviced. When reassembling, follow the steps in reverse order. Bend, route, and dress the cables as they were originally.

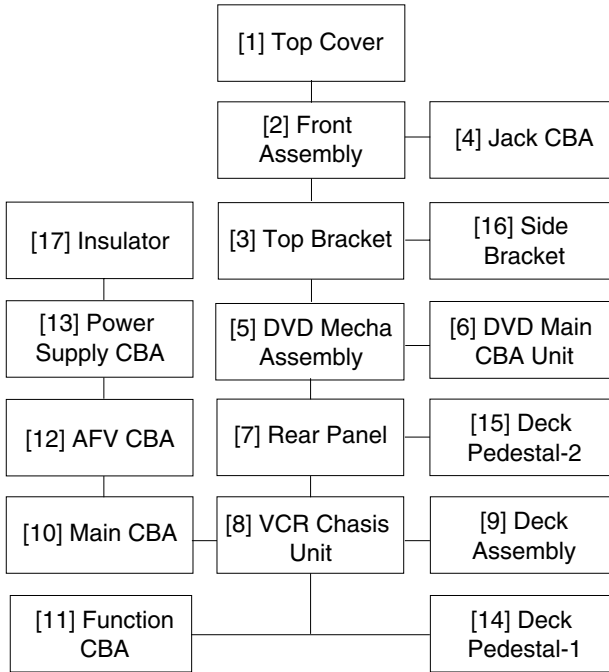

2. Disassembly Method

ID/ LOC. No.	PART	REMOVAL		
		Fig. No.	REMOVE/*UNHOOK/ UNLOCK/RELEASE/ UNPLUG/DESOLDER	Note
[1]	Top Cover	D1	8(S-1)	-
[2]	Front Assembly	D2	*CN505, *2(L-1), Tray Panel, *7(L-2)	1-1 1-2 1-3 1-4 1-5 1-6 1-7 1-8
[3]	Top Bracket	D2	4(S-2)	-
[4]	Jack CBA	D3	3(S-3)	-
[5]	DVD Mecha Assembly	D4	3(S-4), *CN501, *CN701	-

ID/ LOC. No.	PART	REMOVAL		
		Fig. No.	REMOVE/*UNHOOK/ UNLOCK/RELEASE/ UNPLUG/DESOLDER	Note
[6]	DVD Main CBA Unit	D5	3(S-5), *CN101, *CN401	2 2-1 2-2 2-3 3
[7]	Rear Panel	D6	3(S-6), 3(S-7)	-
[8]	VCR Chassis Unit	D7	*CN001, *CN002, 5(S-8), 5(S-9)	-
[9]	Deck Assembly	D8	Desolder, 2(S-10)	4,5
[10]	Main CBA	D8	-----	-
[11]	Function CBA	D8	Desolder, *CN2002	-
[12]	AFV CBA	D8	Desolder	-
[13]	Power Supply CBA	D9	3(S-11), Bracket, *(L-3)	-
[14]	Deck Pedestal-1	D9	6(S-12), 3(W-1)	-
[15]	Deck Pedestal-2	D9	(S-13)	-
[16]	Side Bracket	D9	(S-14)	-
[17]	Insulator	D9	-----	-

↓ ↓ ↓ ↓ ↓
 (1) (2) (3) (4) (5)

Note:

- (1): Identification (location) No. of parts in the figures
- (2): Name of the part
- (3): Figure Number for reference
- (4): Identification of parts to be removed, unhooked, unlocked, released, unplugged, unclamped, or desoldered.
P=Spring, L=Locking Tab, S=Screw, CN=Connector, W=Washer
*=Unhook, Unlock, Release, Unplug, or Desolder
e.g. 2(S-2) = two Screws (S-2),
2(L-2) = two Locking Tabs (L-2)
- (5): Refer to "Reference Notes."

Reference Notes

CAUTION 1: Locking Tabs (L-1) and (L-2) are fragile. Be careful not to break them.

- 1-1. Connect the wall plug to an AC outlet and press the OPEN/CLOSE button to open the Tray.
- 1-2. Remove the Tray Panel by releasing two Locking Tabs (L-1).
- 1-3. Press the OPEN/CLOSE button again to close the Tray.
- 1-4. Press the POWER button to turn the power off.
- 1-5. Unplug an AC cord.
- 1-6. Disconnect connector CN505.
- 1-7. Remove Screw (S-1A).
- 1-8. Release seven Locking Tabs (L-2) (to do this, first release five Locking Tabs (A) at the side and top, and then release two Locking Tabs (B) at the bottom.)

CAUTION 2: Electrostatic breakdown of the laser diode in the optical system block may occur as a potential difference caused by electrostatic charge accumulated on cloth, human body etc., during unpacking or repair work.

To avoid damage of pickup follow next procedures.

- 2-1. Slide the pickup unit as shown in Fig. D5.
- 2-2. Short the three short lands of FPC cable with solder before removing the FFC cable (CN101) from it. If you disconnect the FFC cable (CN101), the laser diode of pickup will be destroyed. (Fig. D5)
- 2-3. Disconnect Connector (CN401). Remove three Screws (S-5) and lift the DVD Main CBA Unit. (Fig. D5)

CAUTION 3: When reassembling, confirm the FFC cable (CN101) is connected completely. Then remove the solder from the three short lands of FPC cable. (Fig. D5)

4. When reassembling, solder wire jumpers as shown in Fig. D8.
5. Before installing the Deck Assembly, be sure to place the pin of LD-SW on Main CBA as shown in Fig. D8. Then, install the Deck Assembly while aligning the hole of Cam Gear with the pin of LD-SW, the shaft of Cam Gear with the hole of LD-SW as shown in Fig. D8.

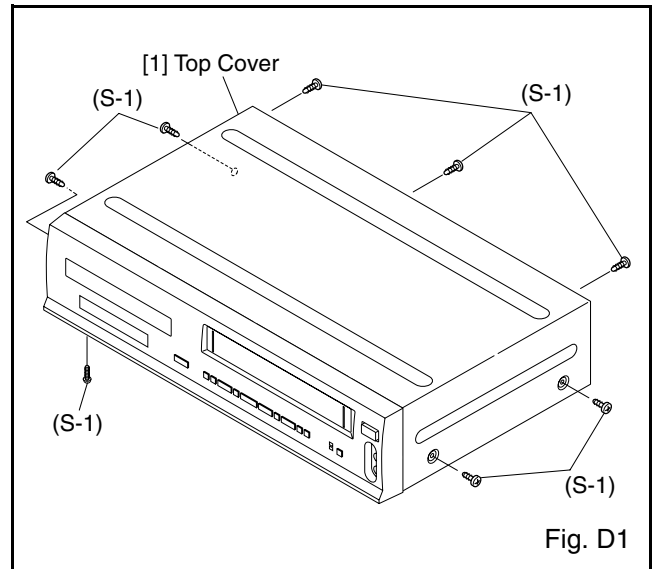

Fig. D1

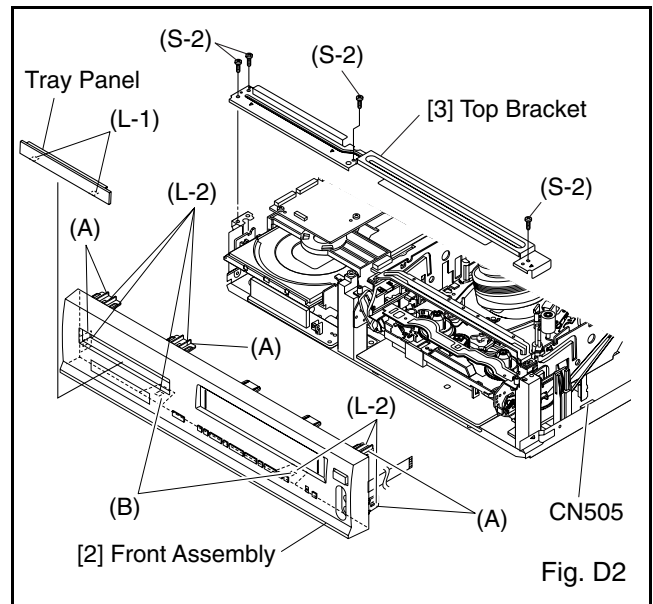

Fig. D2

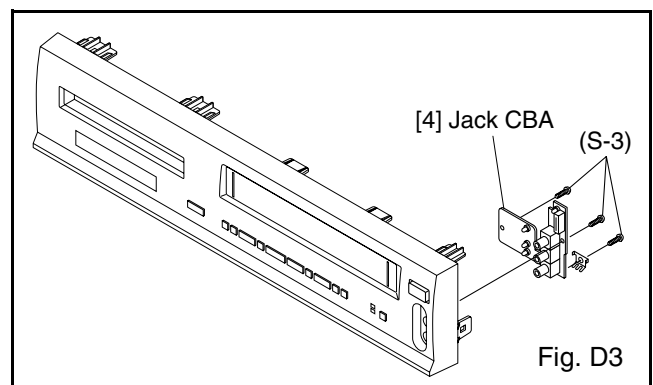

Fig. D3

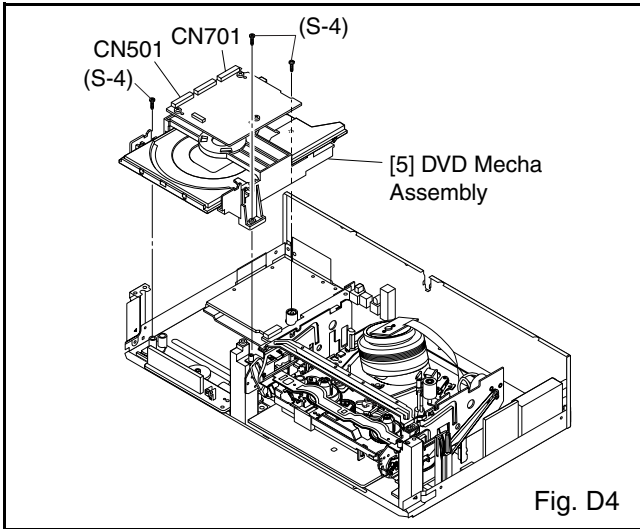

Fig. D4

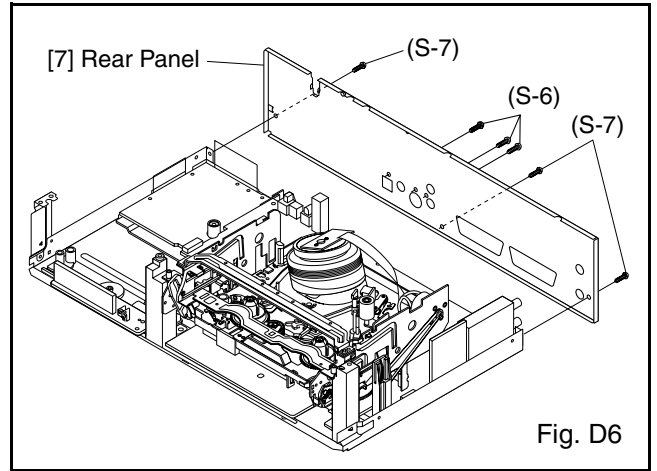
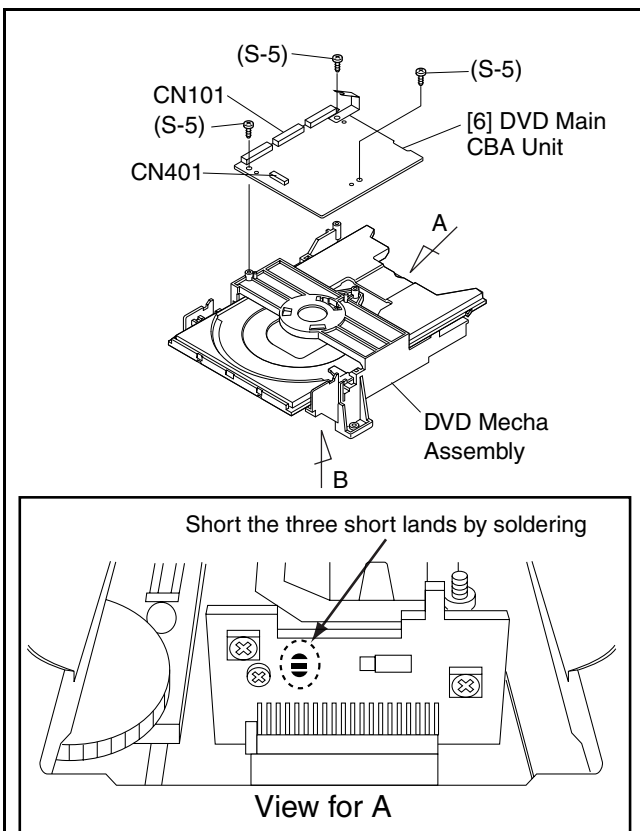

Fig. D6



OR

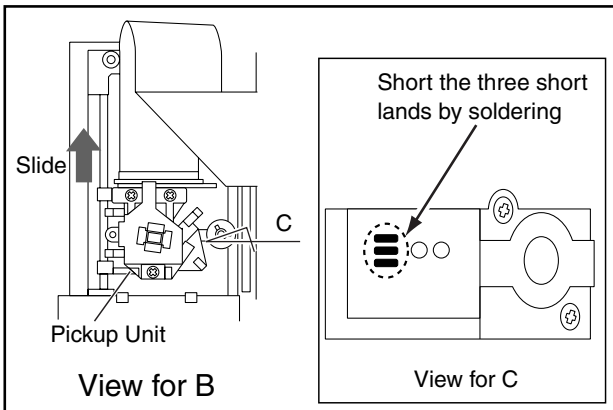

Fig. D5

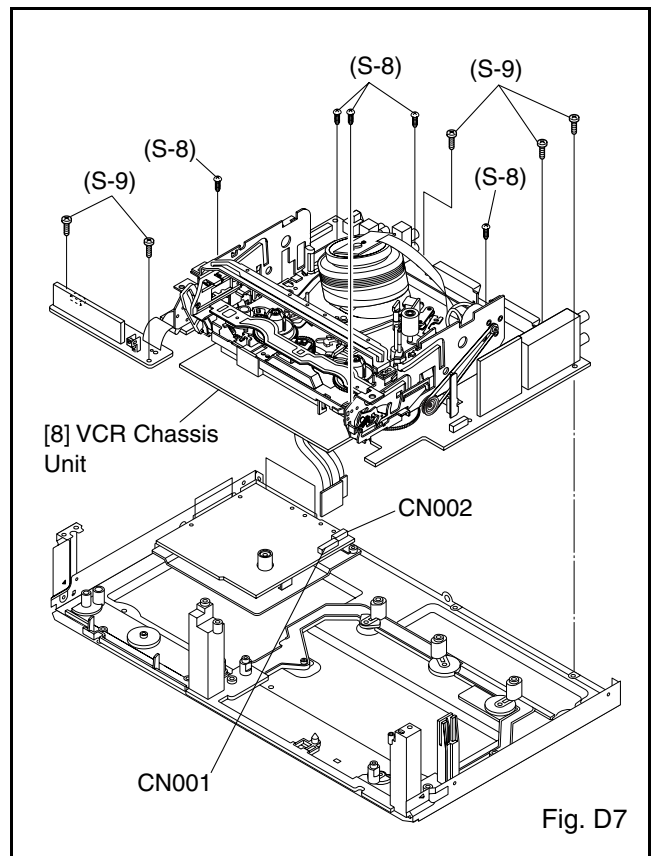

Fig. D7

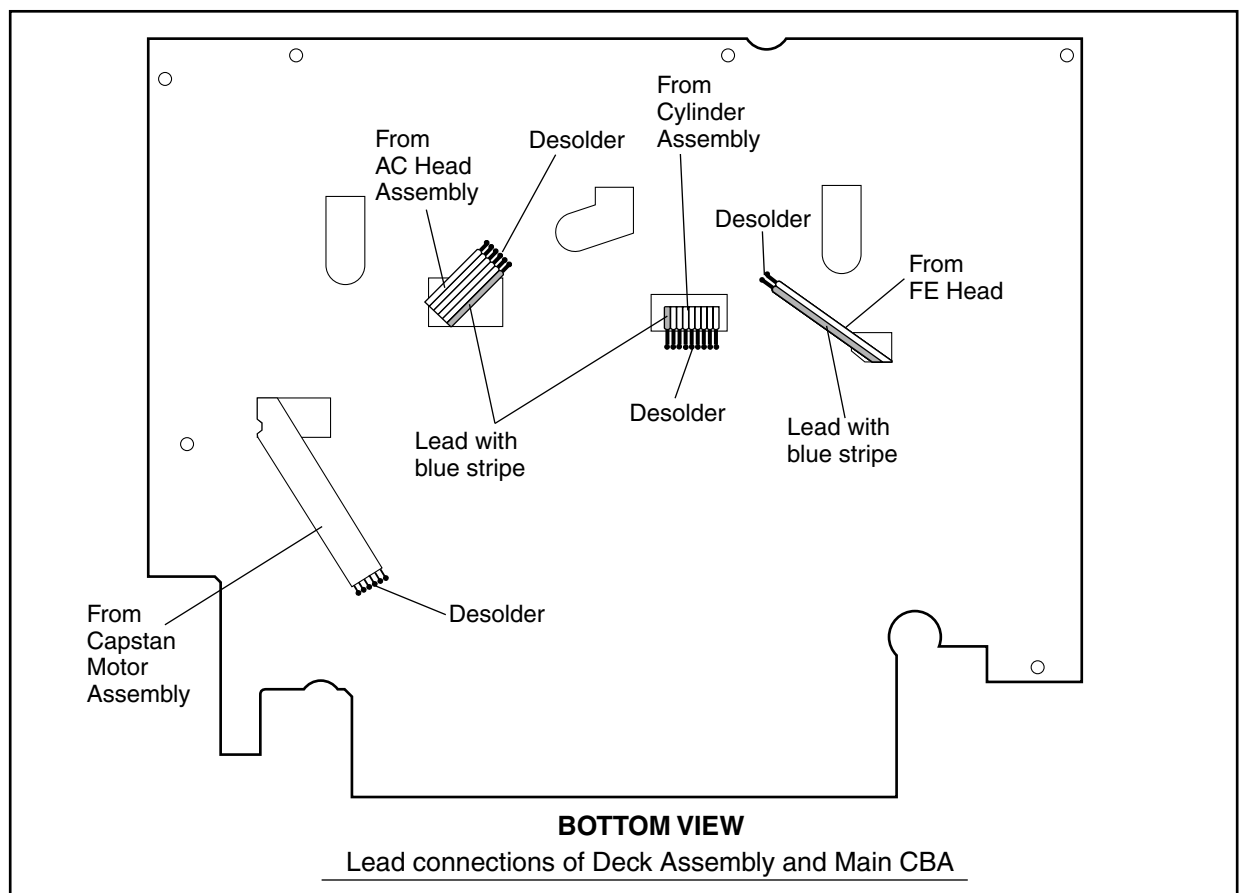
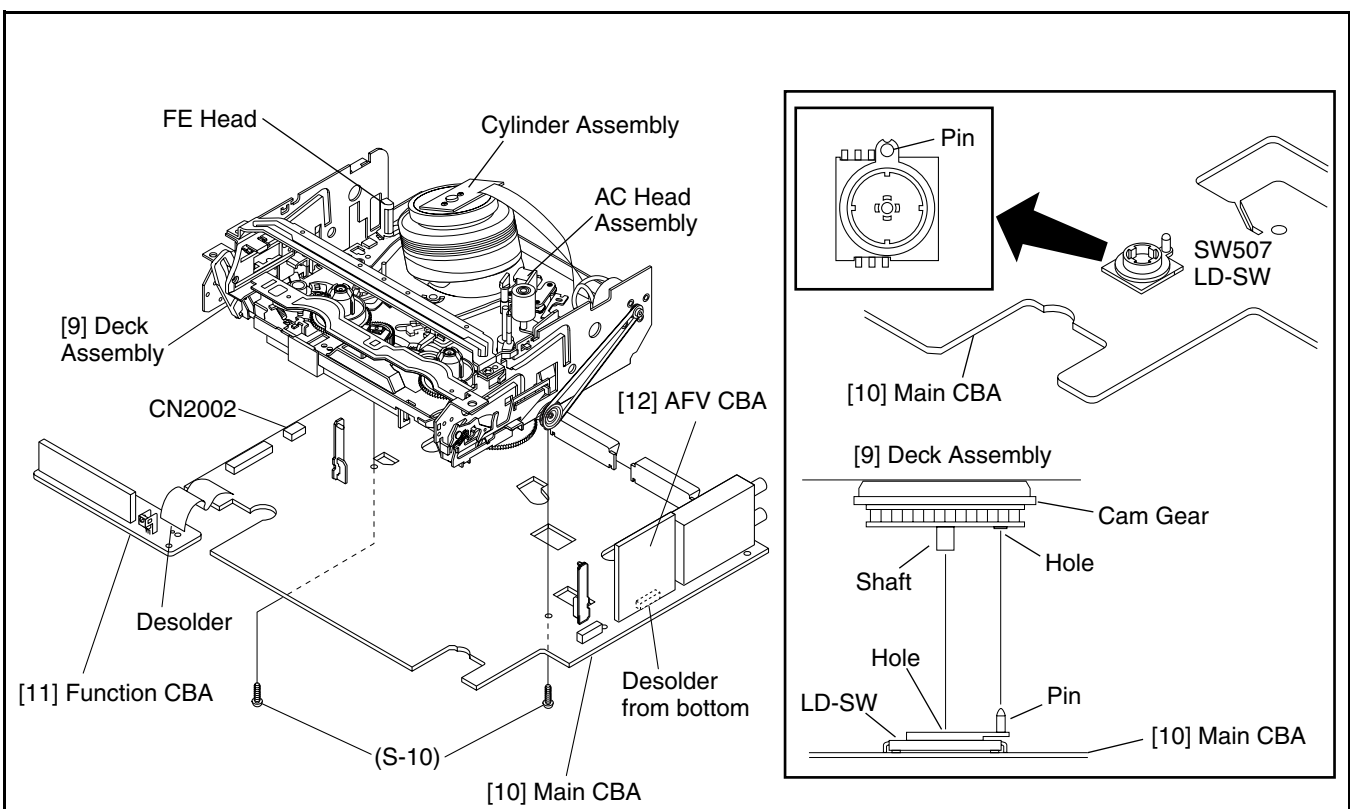

Fig. D8

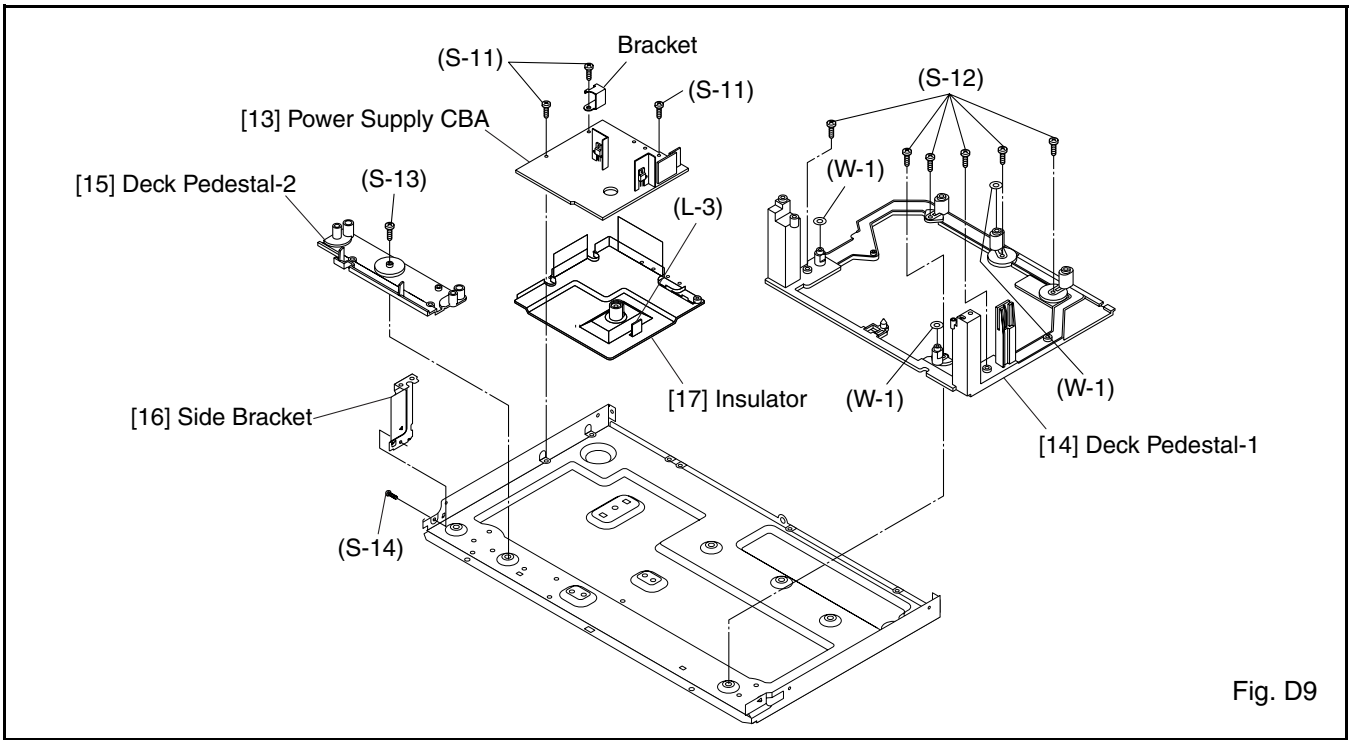
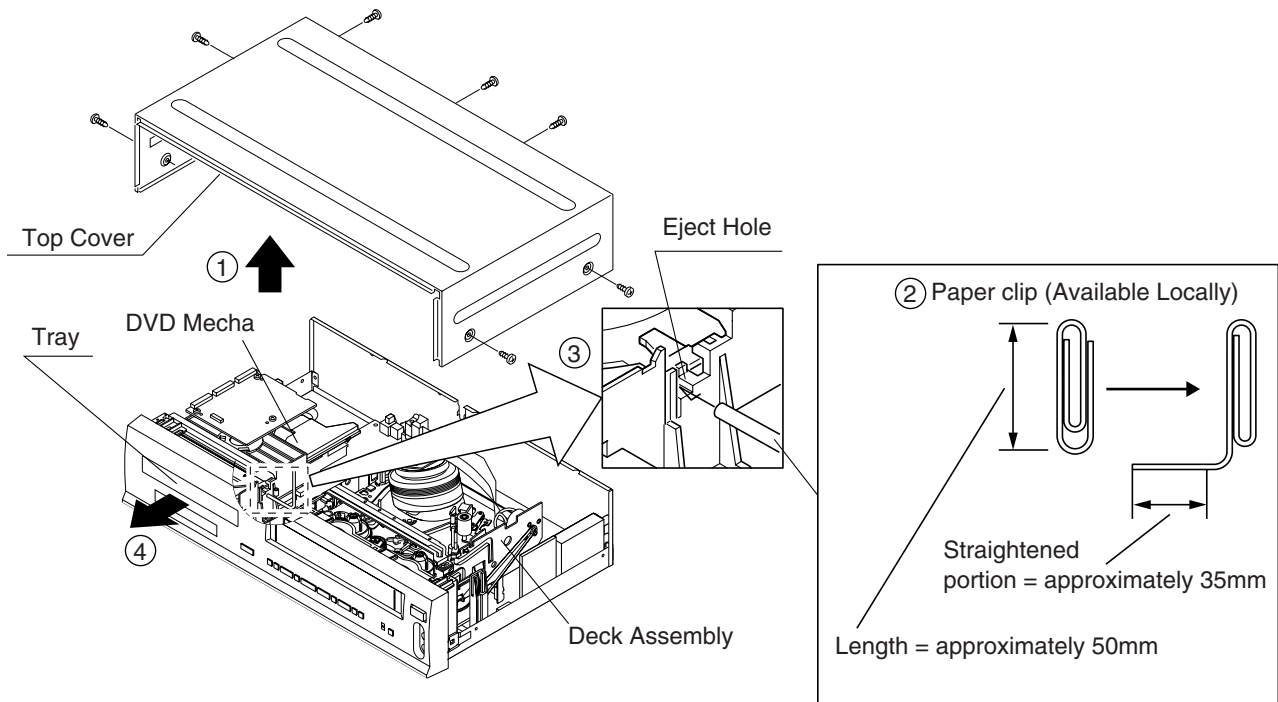

Fig. D9

HOW TO MANUAL EJECT

1. Remove the Top Case.
2. Make a tool from a paper clip, etc., (length = approximately 50 mm, maximum diameter = approximately 3 mm) as shown below.
3. Insert the tool into the manual eject hole on the DVD Mecha. Then, push it until the tray is ejected.



ELECTRICAL ADJUSTMENT INSTRUCTIONS

General Note: "CBA" is an abbreviation for "Circuit Board Assembly."

NOTE:

1. Electrical adjustments are required after replacing circuit components and certain mechanical parts. It is important to do these adjustments only after all repairs and replacements have been completed. Also, do not attempt these adjustments unless the proper equipment is available.
2. To perform these alignment / confirmation procedures, make sure that the tracking control is set in the center position: Press either "▼" or "▲" button on the remote control unit first, then the "PLAY" button (Front Panel only).

Test Equipment Required

1. Oscilloscope: Dual-trace with 10:1 probe,
V-Range: 0.001~50V/Div.,
F-Range: DC~AC~20MHz
2. Alignment Tape (FL6A)

Head Switching Position Adjustment

Purpose:

To determine the Head Switching point during playback.

Symptom of Misadjustment:

May cause Head Switching noise or vertical jitter in the picture.

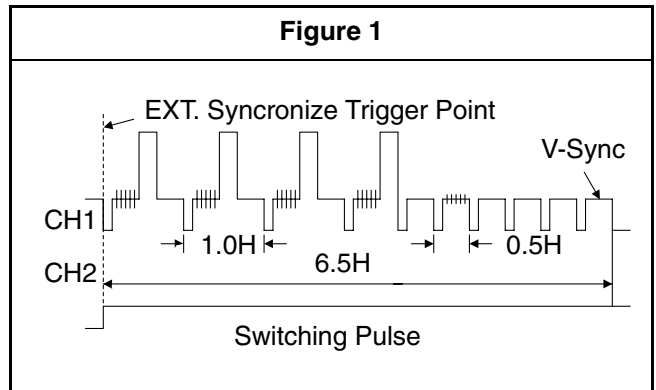

Reference Notes:

Playback the Alignment tape and adjust VR501 so that the V-sync front edge of the CH1 video output waveform is at the 6.5H(412.7µs) delayed position from the rising edge of the CH2 head switching pulse waveform.

Test point	Adj.Point	Mode	Input
TP751(V-OUT) TP302(RF-SW) GND	VR501 (Switching Point) (MAIN CBA)	PLAY (SP)	----
Tape	Measurement Equipment	Spec.	
FL6A	Oscilloscope	6.5H±1H (412.7µs±60µs)	

Connections of Measurement Equipment

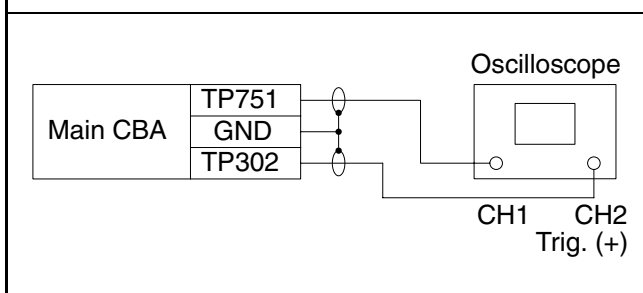

FIRMWARE RENEWAL MODE

1. Turn the power on and remove the disc on the tray.
2. To put the DVD player into version up mode, press [9], [8], [7], [6], and [SEARCH MODE] buttons on the remote control unit in that order. The tray will open automatically.
Fig. a appears on the screen and Fig. b appears on the VFD.

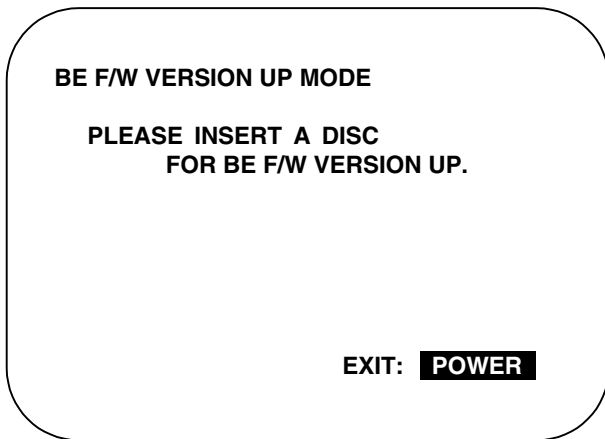

Fig. a Version Up Mode Screen

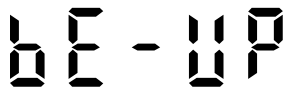

Fig. b VFD in Version Up Mode

The DVD player can also enter the version up mode with the tray open. In this case, Fig. a will be shown on the screen while the tray is open.

3. Load the disc for version up. (For closing the tray, only the "OPEN/CLOSE" button is available.)
4. The DVD player enters the F/W version up mode automatically. Fig. c appears on the screen and Fig. d appears on the VFD.

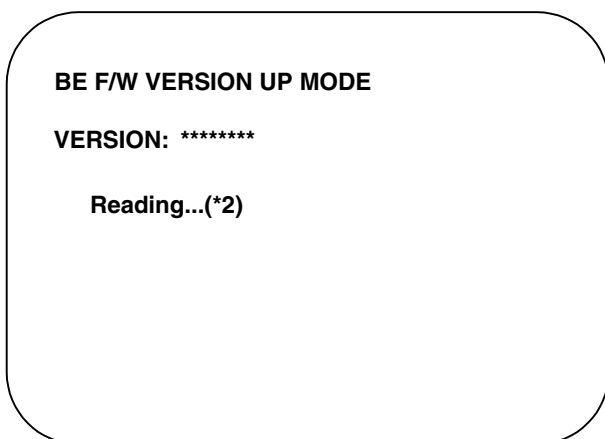

Fig. c Programming Mode Screen



Fig. d VFD in Programming Mode (Example)

The appearance shown in (*2) of Fig. c is described as follows:

No.	Appearance	State
1	Reading...	Sending files into the memory
2	Erasing...	Erasing previous version data
3	Programming...	Writing new version data

5. After programming is finished, the tray opens automatically. Fig. e appears on the screen and the checksum in (*3) of Fig. e appears on the VFD. (Fig. f)

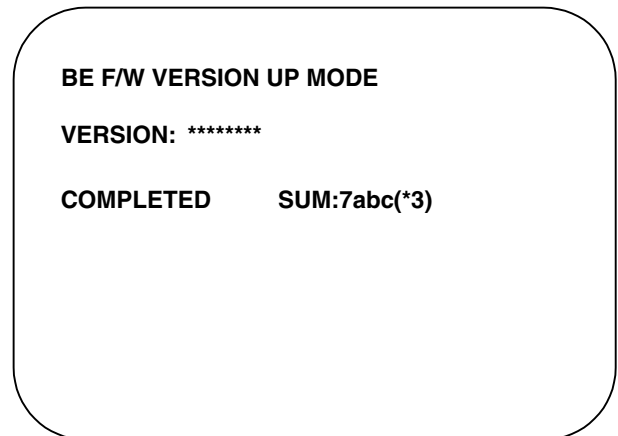

Fig. e Completed Program Mode Screen



Fig. f VFD upon Finishing the Programming Mode (Example)

At this time, no buttons are available.

6. For tray opening, plug the AC cord into the AC outlet.
7. Turn the power on by pressing the power button and the tray will close.

BLOCK DIAGRAMS <VCR Section>

Servo/System Control Block Diagram

TEST POINT INFORMATION

- ⊙ :INDICATES A TEST POINT WITH A JUMPER WIRE ACROSS A HOLE IN THE PCB.
- ⊞ :USED TO INDICATE A TEST POINT WITH A COMPONENT LEAD ON FOIL SIDE.
- ⊘ :USED TO INDICATE A TEST POINT WITH NO TEST PIN.
- :USED TO INDICATE A TEST POINT WITH A TEST PIN.

NOTE FOR WIRE CONNECTORS:

1. PREFIX SYMBOL "CN" MEANS CONNECTOR.
(CAN DISCONNECT AND RECONNECT.)
2. PREFIX SYMBOL "CL" MEANS WIRE-SOLDER HOLES OF THE PCB.
(WIRE IS SOLDERED DIRECTLY.)

"●" = SMD

(DECK ASSEMBLY)

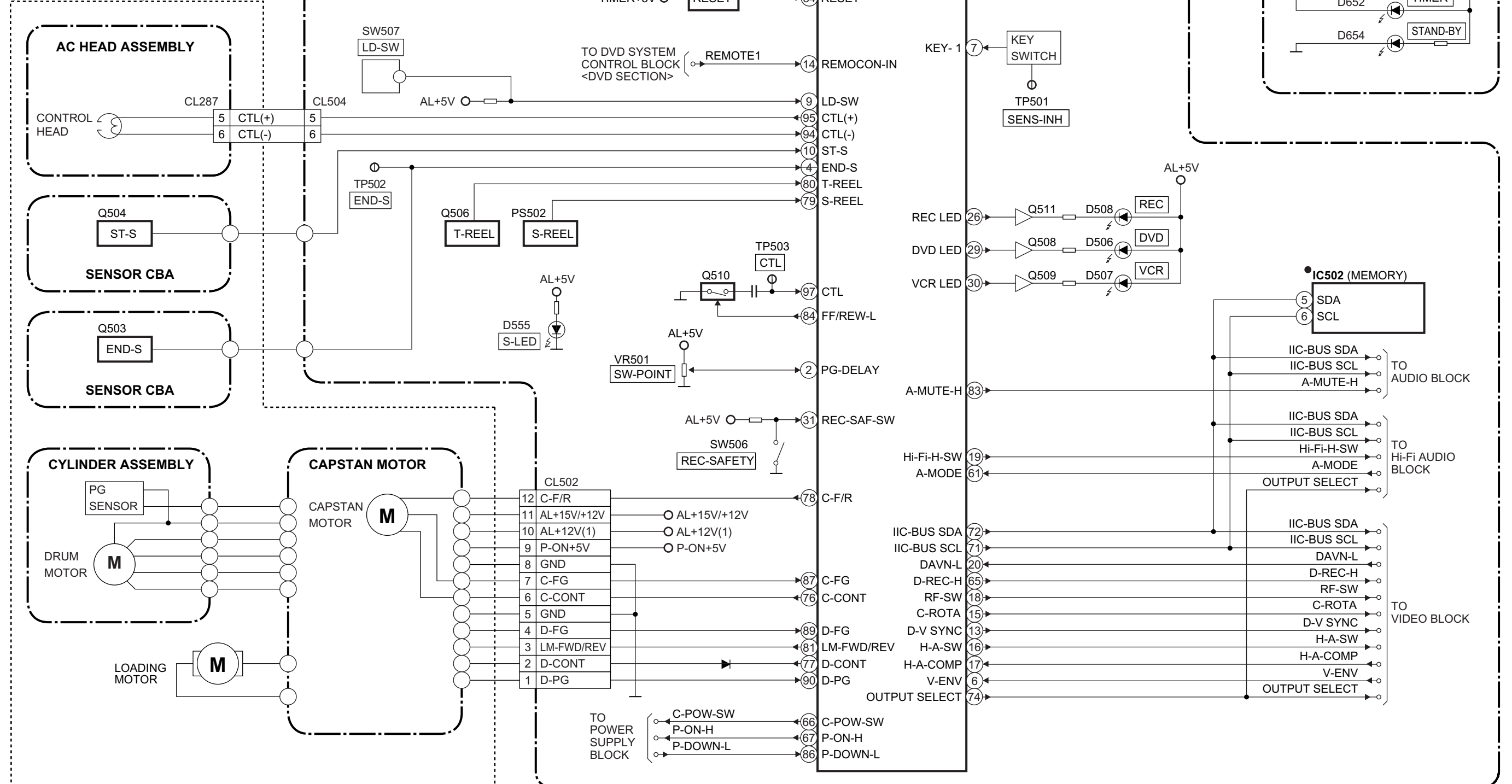

Video Block Diagram

"•" = SMD

NOTE FOR WIRE CONNECTORS:

1. PREFIX SYMBOL "CN" MEANS CONNECTOR. (CAN DISCONNECT AND RECONNECT.)
2. PREFIX SYMBOL "CL" MEANS WIRE-SOLDER HOLES OF THE PCB. (WIRE IS SOLDERED DIRECTLY.)

TEST POINT INFORMATION

- ⊙ : INDICATES A TEST POINT WITH A JUMPER WIRE ACROSS A HOLE IN THE PCB.
- ⊞ : USED TO INDICATE A TEST POINT WITH A COMPONENT LEAD ON FOIL SIDE.
- ⊚ : USED TO INDICATE A TEST POINT WITH NO TEST PIN.
- : USED TO INDICATE A TEST POINT WITH A TEST PIN.

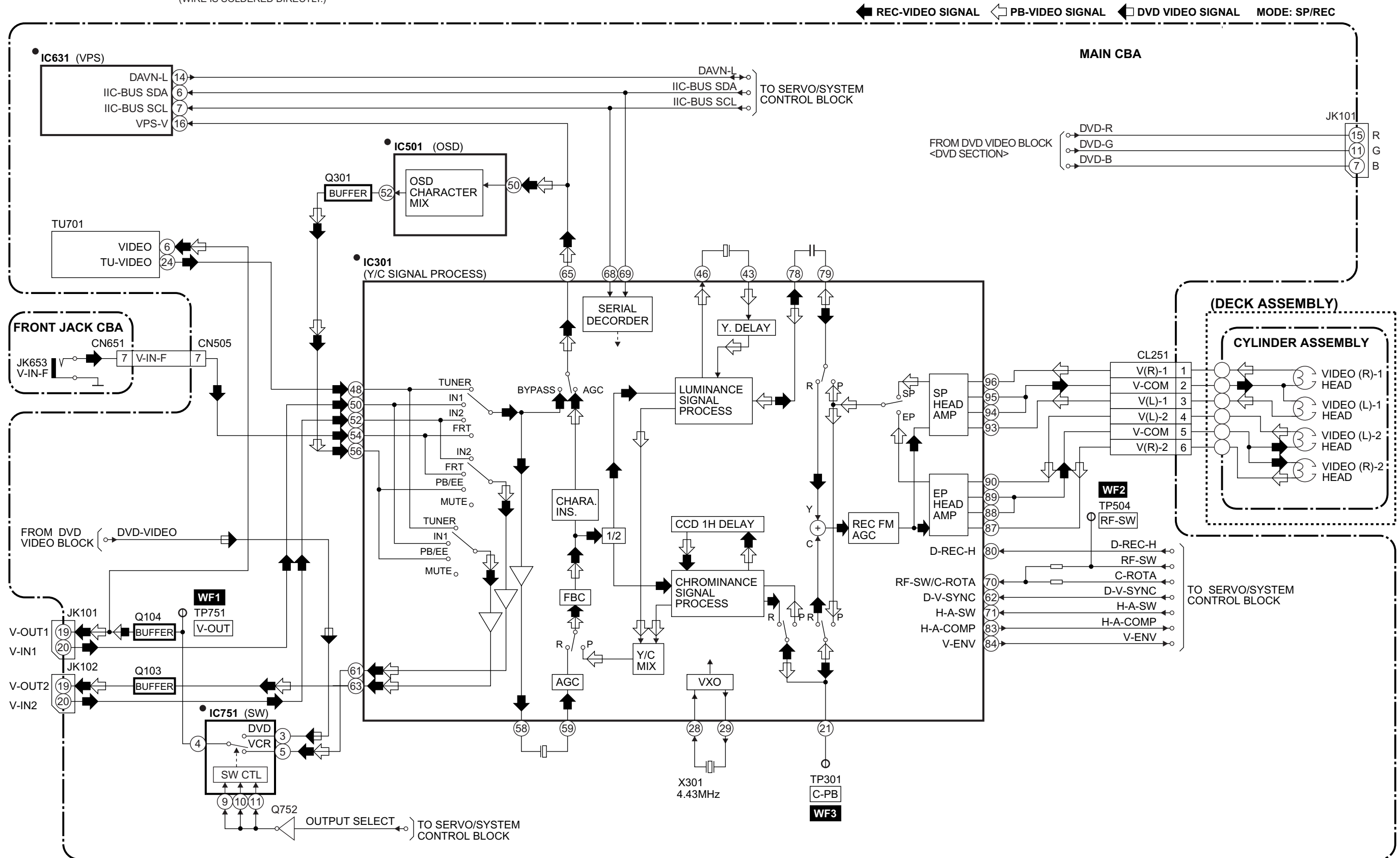

Audio Block Diagram

"●" = SMD

NOTE FOR WIRE CONNECTORS:
 1. PREFIX SYMBOL "CN" MEANS CONNECTOR.
 (CAN DISCONNECT AND RECONNECT.)
 2. PREFIX SYMBOL "CL" MEANS WIRE-SOLDER
 HOLES OF THE PCB.
 (WIRE IS SOLDERED DIRECTLY.)

PB-AUDIO SIGNAL **REC-AUDIO SIGNAL** Mode : SP/REC

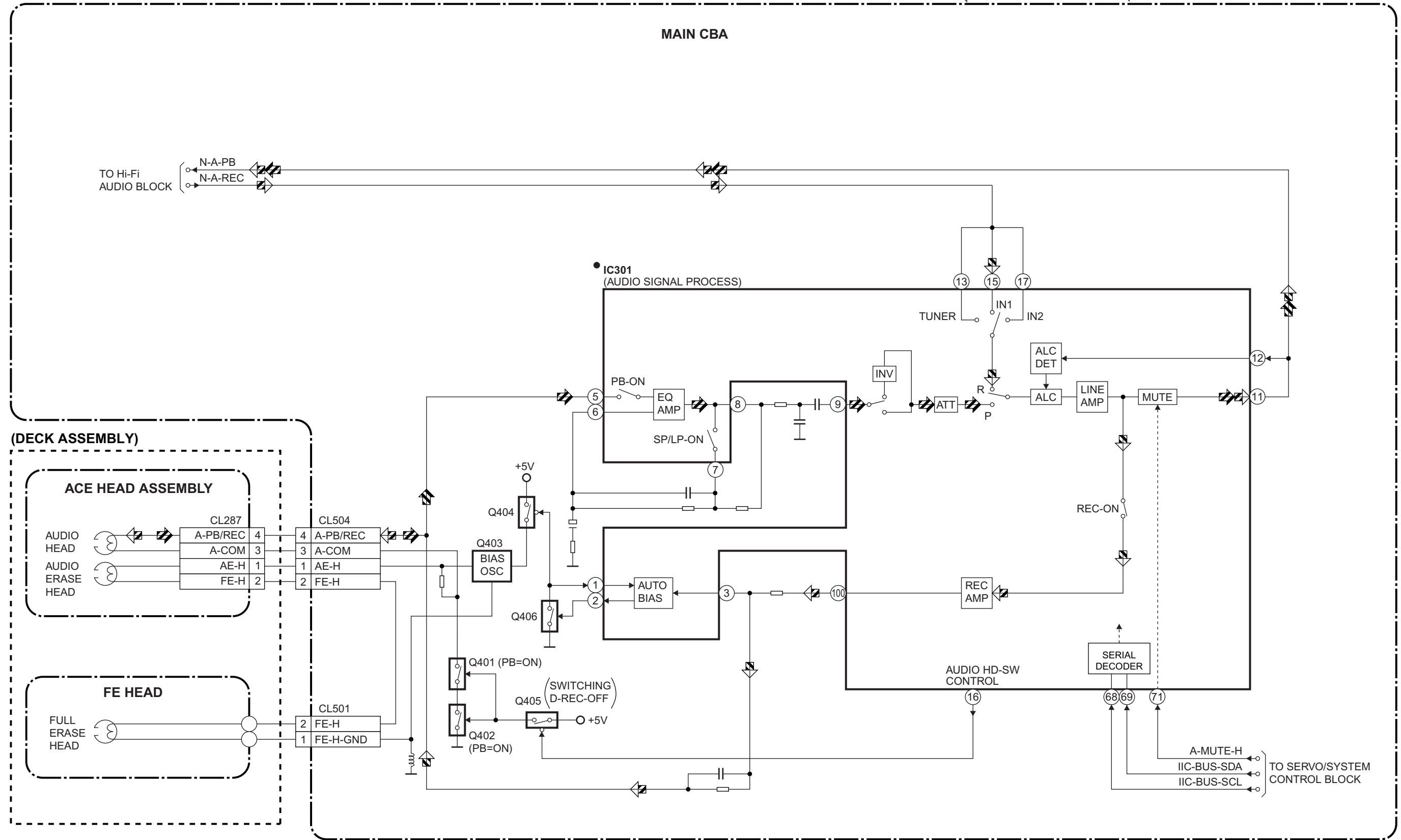

Hi-Fi Audio Block Diagram

● = SMD

NOTE FOR WIRE CONNECTORS:
 1. PREFIX SYMBOL "CN" MEANS CONNECTOR.
 (CAN DISCONNECT AND RECONNECT.)
 2. PREFIX SYMBOL "CL" MEANS WIRE-SOLDER
 HOLES OF THE PCB.
 (WIRE IS SOLDERED DIRECTLY.)

 PB-AUDIO SIGNAL
  REC-AUDIO SIGNAL
  DVD AUDIO SIGNAL
 Mode : SP/REC

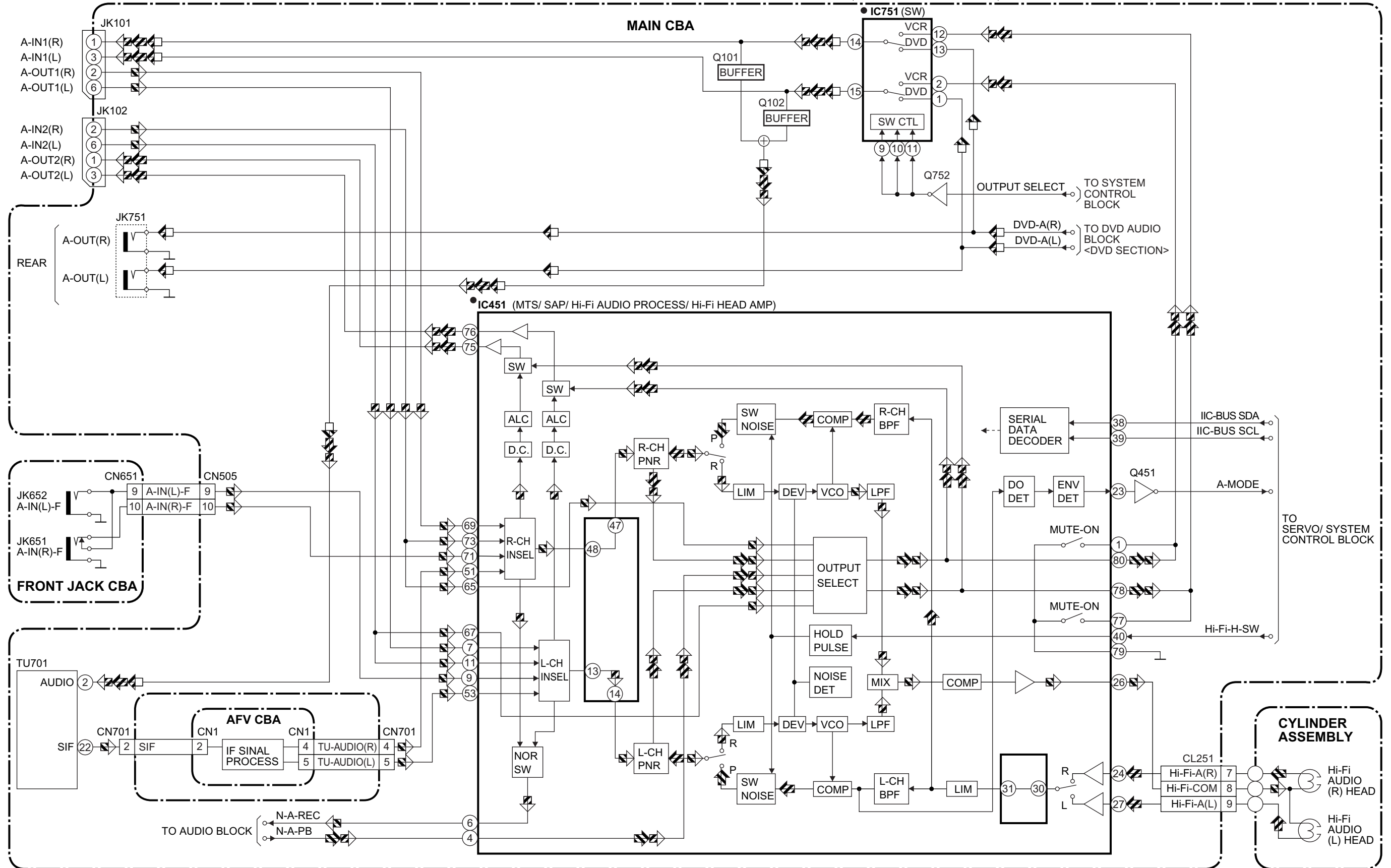

Power Supply Block Diagram

NOTE :
The voltage for parts in hot circuit is measured using hot GND as a common terminal.

CAUTION
FOR CONTINUED PROTECTION AGAINST FIRE HAZARD,
REPLACE ONLY WITH THE SAME TYPE T1.6AL/250V FUSE.

CAUTION !
Fixed voltage (or Auto voltage selectable) power supply circuit is used in this unit.
If Main Fuse (F001) is blown, check to see that all components in the power supply circuit are not defective before you connect the AC plug to the AC power supply.
Otherwise it may cause some components in the power supply circuit to fail.

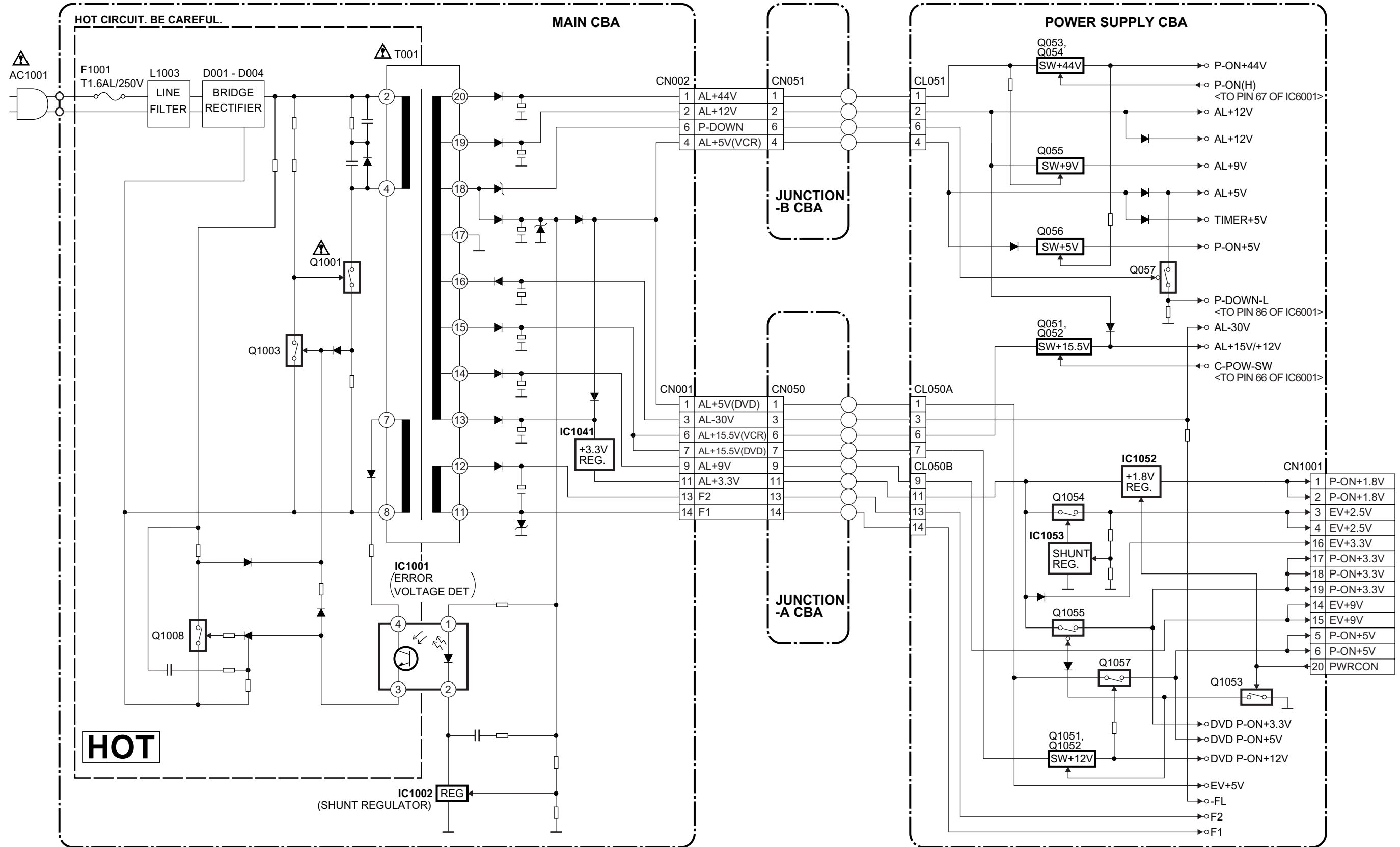

BLOCK DIAGRAMS < DVD Section >

DVD System Control Block Diagram

"●" = SMD

NOTE FOR WIRE CONNECTORS:
 1. PREFIX SYMBOL "CN" MEANS CONNECTOR.
 (CAN DISCONNECT AND RECONNECT.)
 2. PREFIX SYMBOL "CL" MEANS WIRE-SOLDER
 HOLES OF THE PCB.
 (WIRE IS SOLDERED DIRECTLY.)

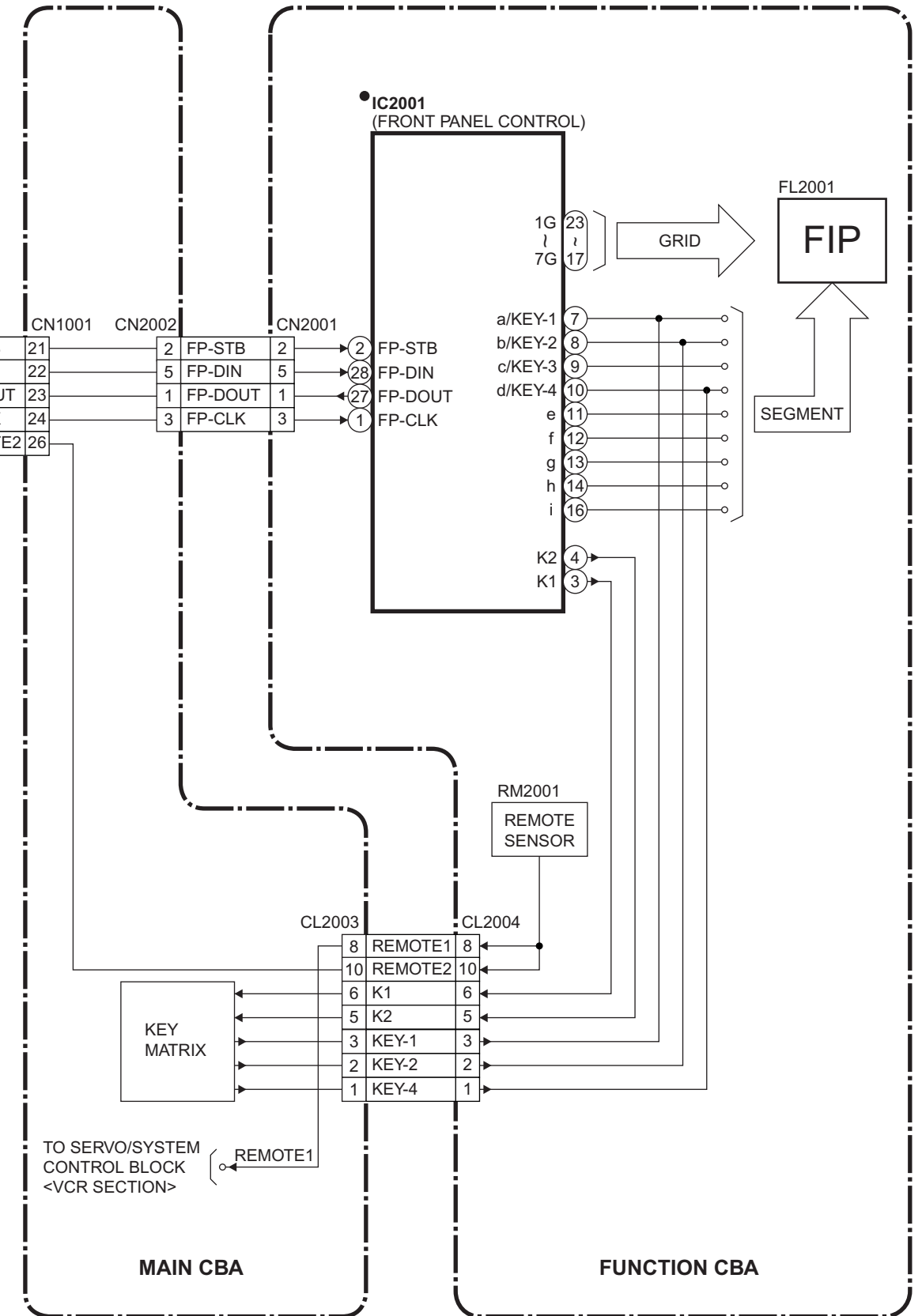
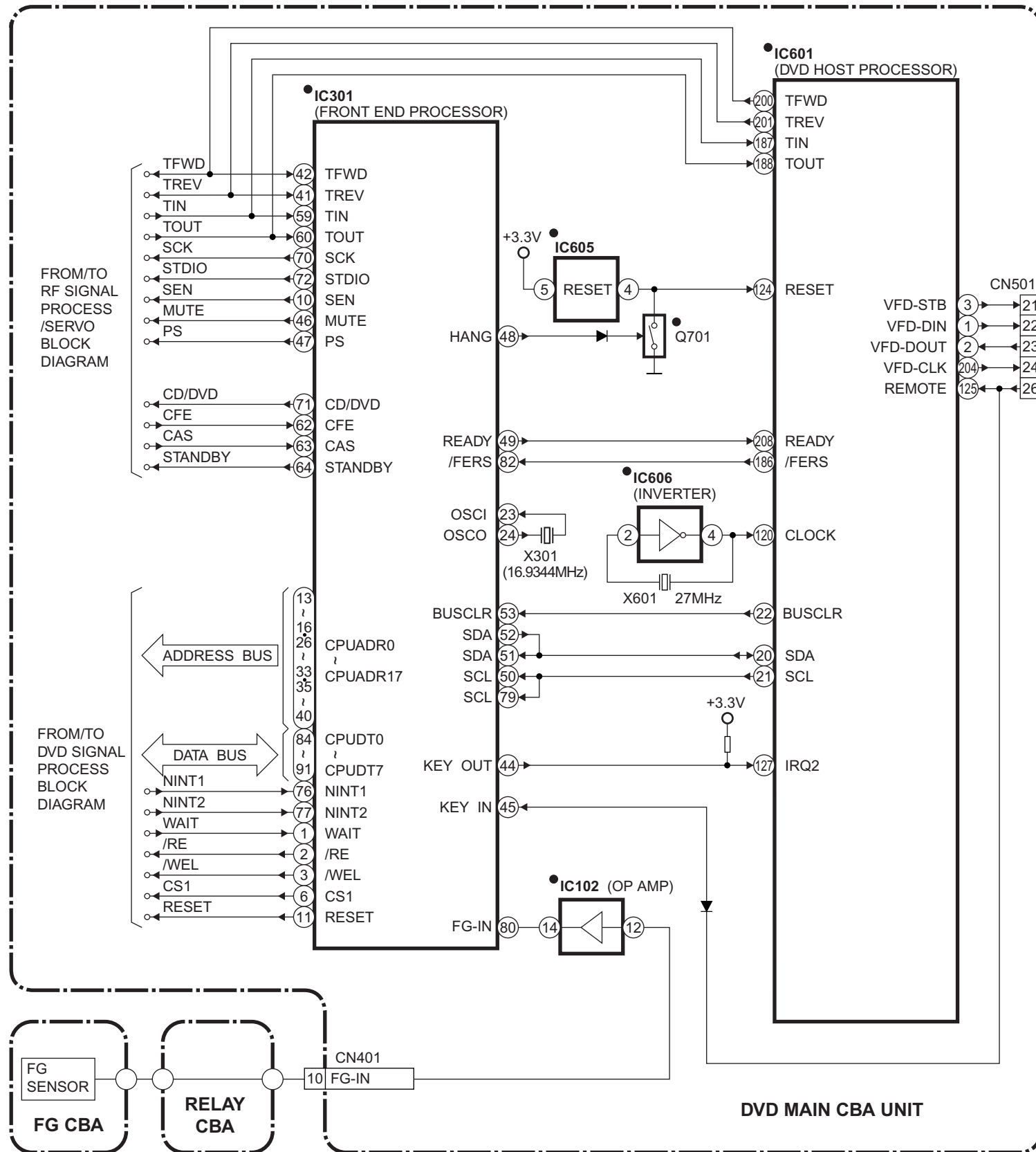

RF Signal Process/Servo Block Diagram

"●" = SMD

NOTE FOR WIRE CONNECTORS:

1. PREFIX SYMBOL "CN" MEANS CONNECTOR. (CAN DISCONNECT AND RECONNECT.)
2. PREFIX SYMBOL "CL" MEANS WIRE-SOLDER HOLES OF THE PCB. (WIRE IS SOLDERED DIRECTLY.)

◀ DATA(VIDEO/AUDIO) SIGNAL ◀ FOCUS SERVO SIGNAL ◀ TRACKING SERVO SIGNAL ◀ SLIDE SERVO SIGNAL ◀ DISK SERVO SIGNAL

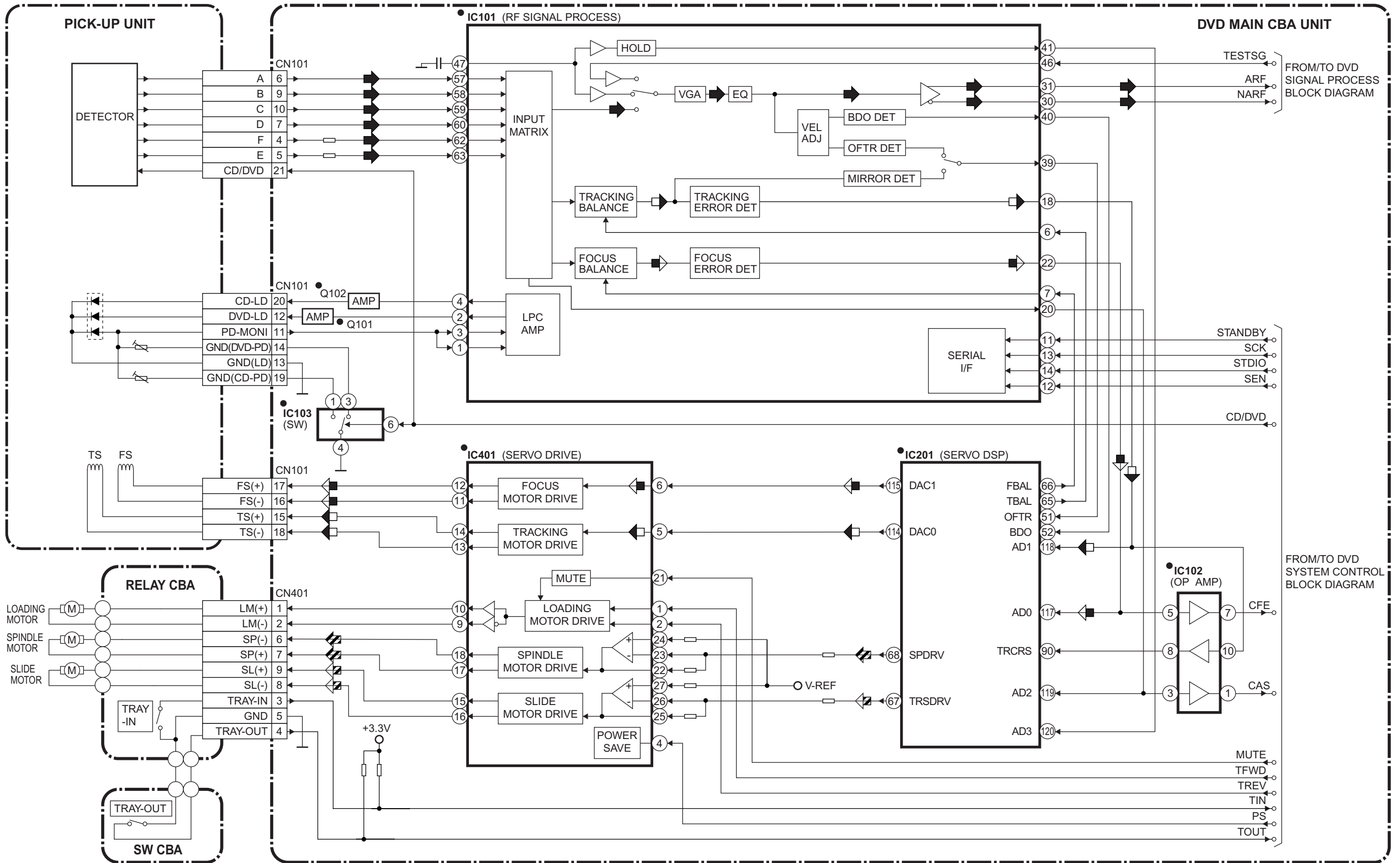

DVD Signal Process Block Diagram

"●" = SMD

NOTE FOR WIRE CONNECTORS:
 1. PREFIX SYMBOL "CN" MEANS CONNECTOR.
 (CAN DISCONNECT AND RECONNECT.)
 2. PREFIX SYMBOL "CL" MEANS WIRE-SOLDER
 HOLES OF THE PCB.
 (WIRE IS SOLDERED DIRECTLY.)

← DATA(VIDEO/AUDIO) SIGNAL

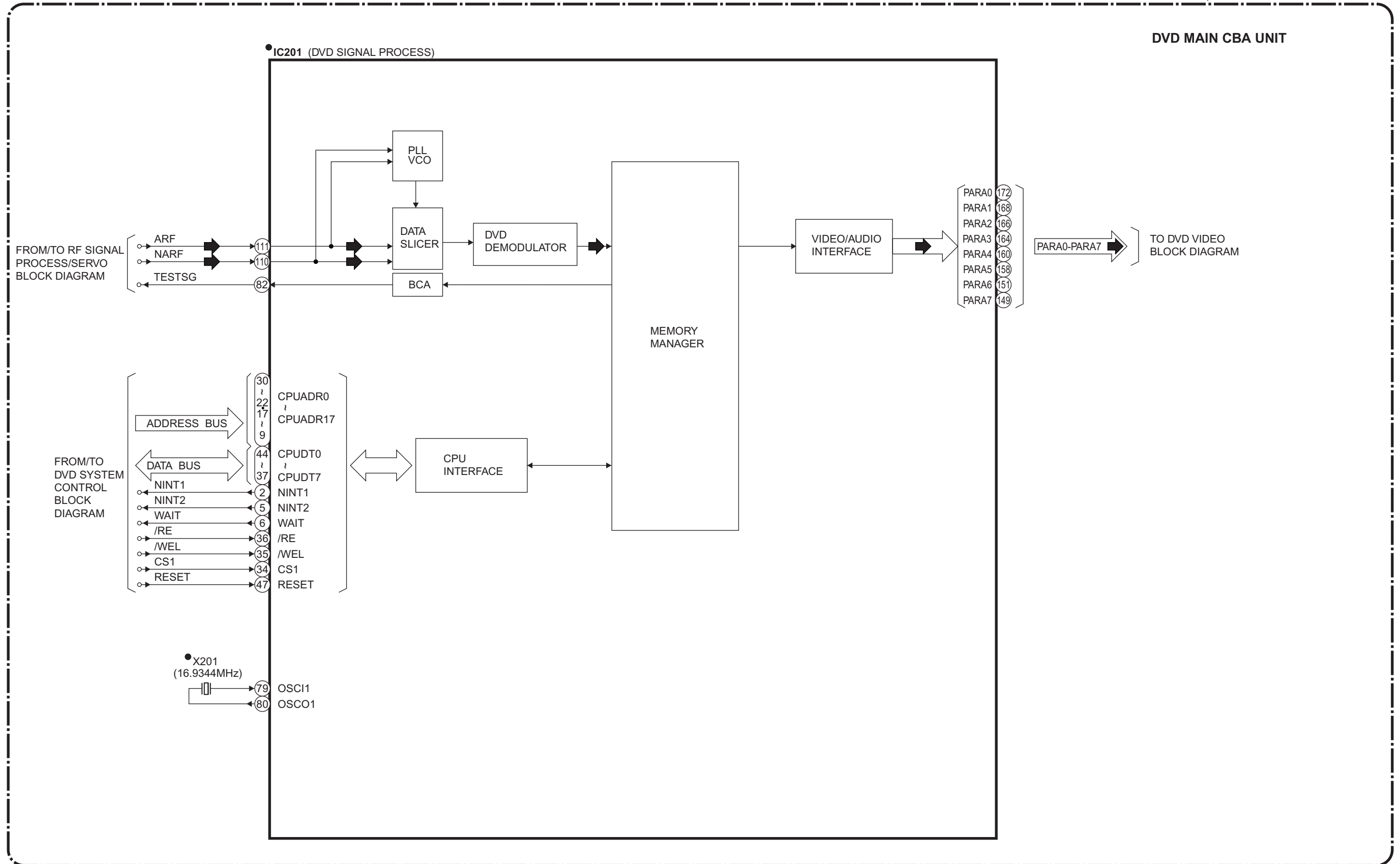

DVD Video Block Diagram

"●" = SMD

NOTE FOR WIRE CONNECTORS:
 1. PREFIX SYMBOL "CN" MEANS CONNECTOR.
 (CAN DISCONNECT AND RECONNECT.)
 2. PREFIX SYMBOL "CL" MEANS WIRE-SOLDER
 HOLES OF THE PCB.
 (WIRE IS SOLDERED DIRECTLY.)

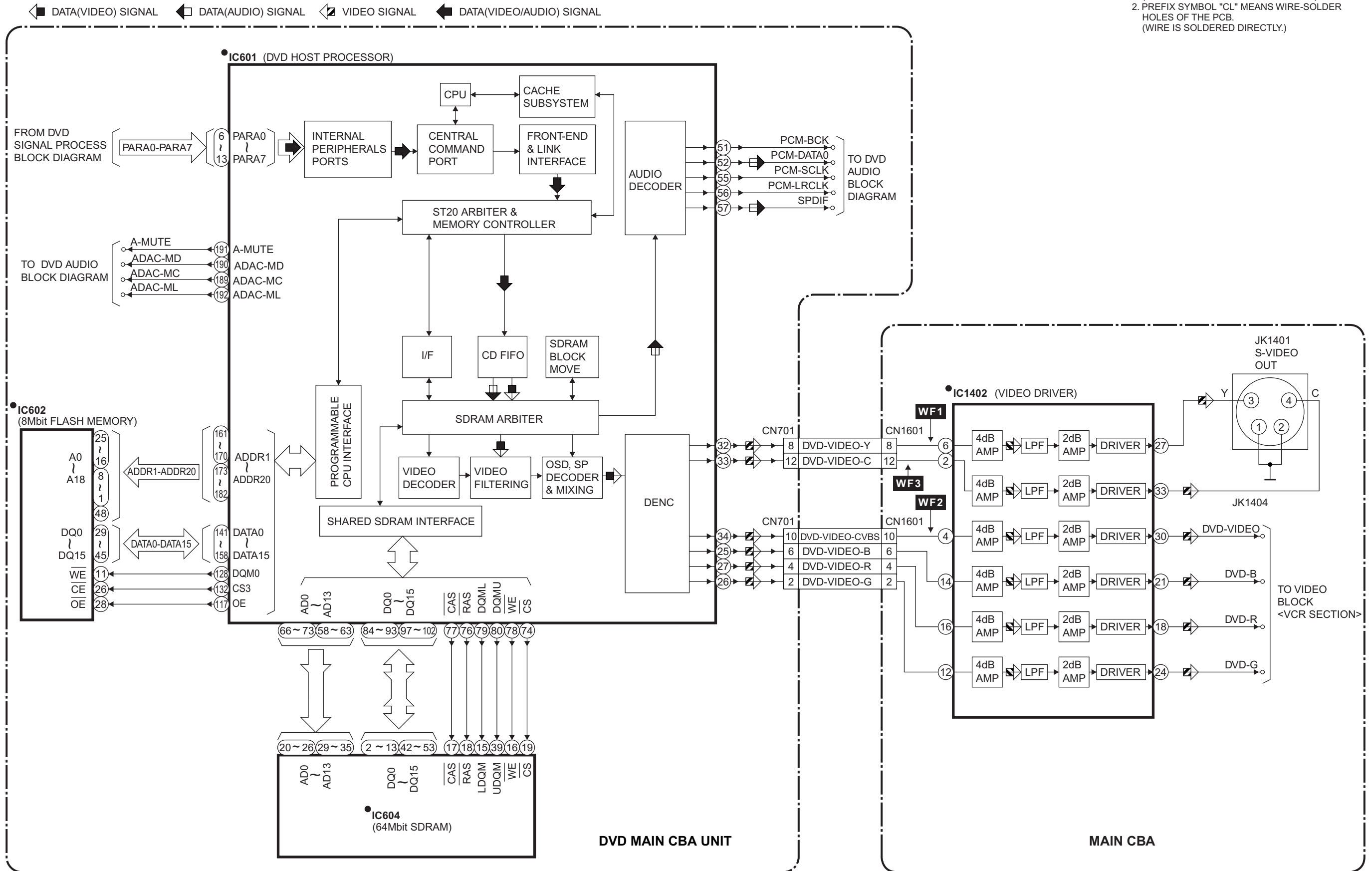

DVD Audio Block Diagram

"●" = SMD

NOTE FOR WIRE CONNECTORS:

1. PREFIX SYMBOL "CN" MEANS CONNECTOR.
(CAN DISCONNECT AND RECONNECT.)
2. PREFIX SYMBOL "CL" MEANS WIRE-SOLDER
HOLES OF THE PCB.
(WIRE IS SOLDERED DIRECTLY.)

◻ DATA(AUDIO) SIGNAL

▨ AUDIO SIGNAL

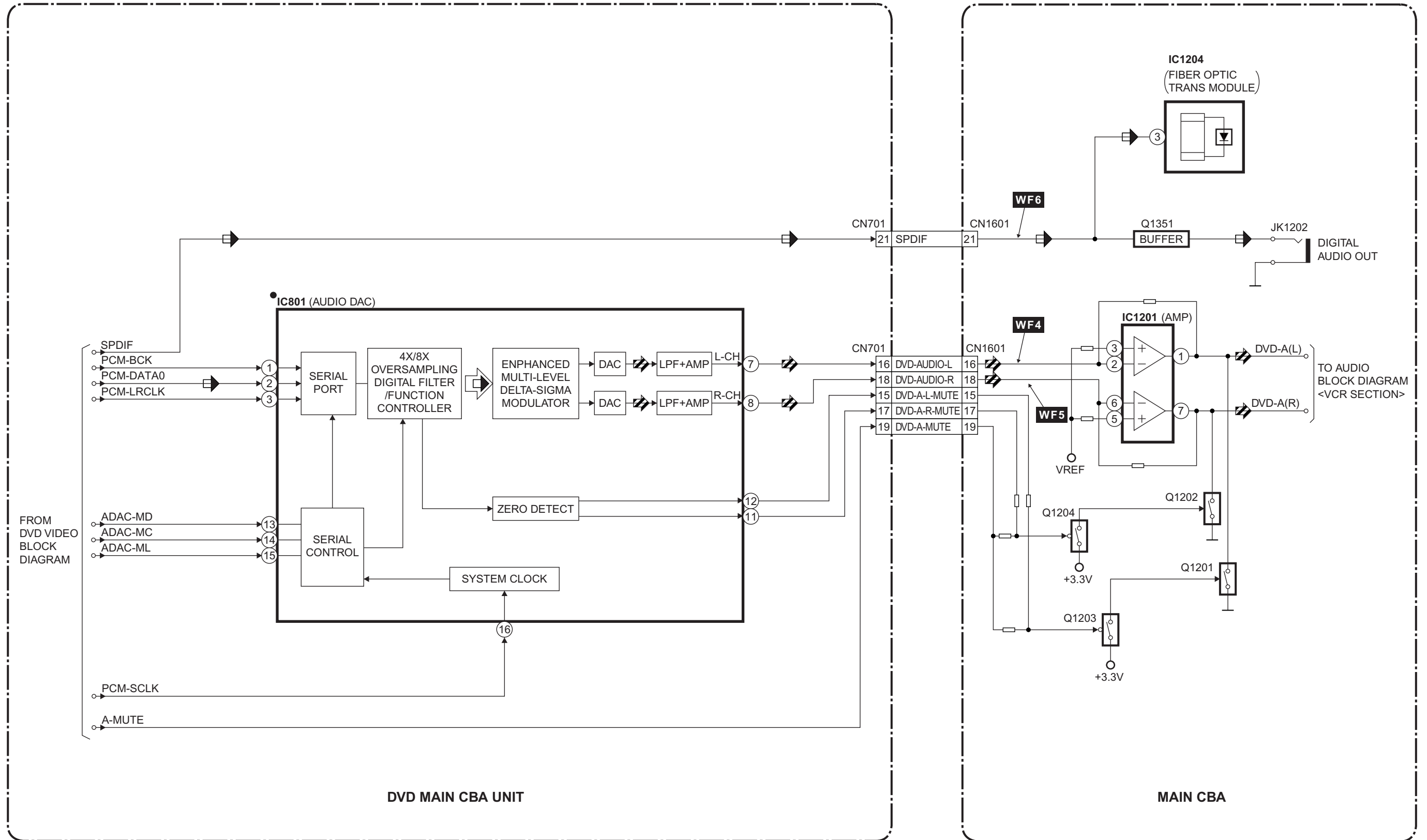

SCHEMATIC DIAGRAMS / CBA'S AND TEST POINTS

Standard Notes

WARNING

Many electrical and mechanical parts in this chassis have special characteristics. These characteristics often pass unnoticed and the protection afforded by them cannot necessarily be obtained by using replacement components rated for higher voltage, wattage, etc. Replacement parts that have these special safety characteristics are identified in this manual and its supplements; electrical components having such features are identified by the mark "⚠" in the schematic diagram and the parts list. Before replacing any of these components, read the parts list in this manual carefully. The use of substitute replacement parts that do not have the same safety characteristics as specified in the parts list may create shock, fire, or other hazards.

Capacitor Temperature Markings

Mark	Capacity change rate	Standard temperature	Temperature range
(B)	±10%	20°C	-25~+85°C
(F)	±30 - 80%	20°C	-25~+85°C
(SR)	±15%	20°C	-25~+85°C
(Y)	±22.5%	20°C	-25~+85°C

Capacitors and transistors are represented by the following symbols.

< PCB Symbols >

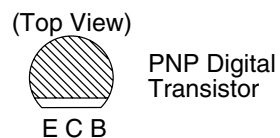
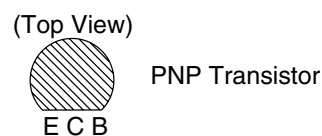
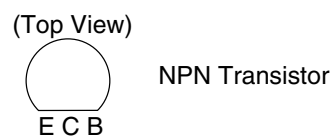
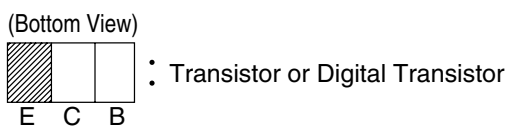
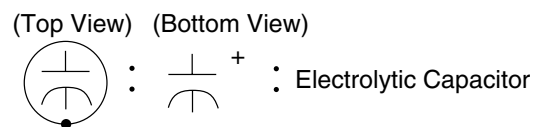

Notes:

- Do not use the part number shown on these drawings for ordering. The correct part number is shown in the parts list, and may be slightly different or amended since these drawings were prepared.
- To maintain original function and reliability of repaired units, use only original replacement parts which are listed with their part numbers in the parts list section of the service manual.
- Prefix symbol "CN" means "connector" (can disconnect and reconnect). Prefix symbol "CL" means "wire-solder holes of the PCB" (wire is soldered directly).
- How to read converged lines.

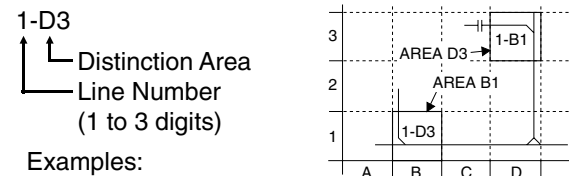

Examples:

- "1-D3" means that line number "1" goes to area "D3."
- "1-B1" means that line number "1" goes to area "B1."

- All resistance values are indicated in ohms ($K=10^3, M=10^6$).
- Resistor wattages are 1/4W or 1/6W unless otherwise specified.
- All capacitance values are indicated in μF ($P=10^{-6} \mu F$).
- All voltages are DC voltages unless otherwise specified.
- Voltage indications for PLAY and REC modes on the schematics are as shown below.

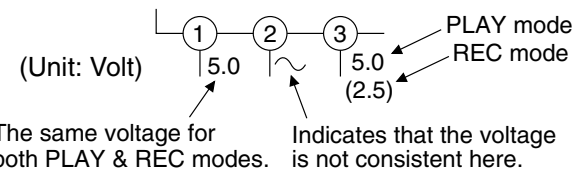

< Schematic Diagram Symbols >

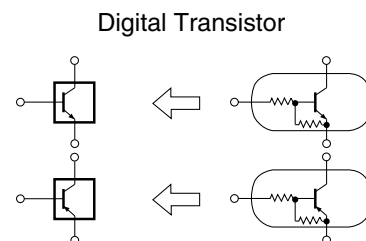

Main 1/8 Schematic Diagram Parts Location Guide

Ref No.	Position	Ref No.	Position	Ref No.	Position
CAPACITORS		COILS		RESISTORS	
C505	B-3	L503	E-3	R544	C-1
C506	B-1	TRANSISTORS		R545	C-1
C508	B-1	Q501	B-5	R546	C-2
C509	B-2	Q502	B-5	R547	C-1
C510	B-2	Q503	A-1	R548	C-1
C511	B-3	Q504	A-2	R550	C-1
C513	B-2	Q506	A-3	R553	D-1
C514	B-2	Q507	B-5	R555	D-1
C516	B-2	Q508	C-5	R557	D-4
C517	B-2	Q509	C-5	R563	D-1
C519	B-2	Q510	B-2	R565	C-4
C521	B-2	Q511	C-5	R566	C-4
C522	C-2	Q513	E-3	R567	E-5
C524	C-3	Q514	E-3	R568	F-5
C527	D-1	Q515	E-2	R569	F-4
C531	F-5	RESISTORS		R570	E-1
C533	F-5	R501	A-3	R572	E-3
C534	D-4	R502	A-3	R574	E-2
C535	E-3	R503	A-3	R575	E-2
C538	E-3	R504	A-3	R576	E-2
C539	E-3	R505	A-2	R577	E-3
C540	E-3	R506	A-2	R578	E-3
C541	E-2	R507	A-2	R581	E-3
C542	E-2	R508	B-5	R582	E-2
C543	E-2	R509	A-3	R583	E-2
C544	E-2	R511	A-2	R584	E-3
C545	E-3	R512	A-3	R585	F-2
C546	E-3	R513	B-3	R586	F-2
C547	E-3	R514	A-2	R587	F-3
C548	E-2	R515	B-5	R588	F-3
C549	E-2	R516	A-2	R589	A-2
C550	E-2	R517	A-1	R591	F-4
C553	F-2	R519	A-2	SWITCHES	
C554	E-4	R520	C-5	SW501	A-3
C555	F-1	R522	C-5	SW502	A-3
CONNECTORS		R523	A-2	SW503	A-3
CL501	F-4	R524	B-5	SW504	A-3
CL502	F-5	R525	B-2	SW505	A-3
CL504	F-5	R526	B-2	SW506	E-1
CN505	A-5	R528	B-2	SW507	A-2
DIODES		R529	B-5	SW508	A-2
D506	C-5	R530	C-5	SW511	E-2
D507	C-5	R531	C-5	VARIABLE RESISTORS	
D508	C-5	R532	C-5	VR501	B-1
D510	E-4	R533	C-5	CRYSTAL OSCILLATORS	
D511	E-3	R534	C-5	X501	E-2
D512	E-3	R535	C-5	X502	E-2
D513	E-4	R536	B-2	MISCELLANEOUS	
D555	A-1	R537	B-2	PS502	B-3
ICS		R538	B-3	TEST POINTS	
IC501	C-3	R539	B-4	TP501	A-2
IC502	B-4	R540	B-4	TP502	B-2
COILS		R541	C-1	TP503	B-2
L501	B-1	R542	C-1	TP504	D-1
L502	D-4	R543	C-2		

Main 1/8 Schematic Diagram < VCR Section >

*1 Note:
When it is necessary to replace one or more of the following Diodes,
all three should be replaced: D506, D507, D508.

*• = SMD

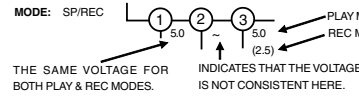

Comparison Chart of Models and Marks

MODEL	MARK
DVD740VR/001	A
DVD740VR/051	B

IC501 KEY VOLTAGE CHART

Voltage	Pin No.	KEY 1 (7PIN)	KEY 2 (8 PIN)
0.00 ~ 0.51V		OUTPUT	TIMER
0.51 ~ 0.92V		STOP/EJECT	POWER
0.92 ~ 1.27V		REW	CH UP
1.27 ~ 1.61V		PLAY	CH DOWN
1.61 ~ 1.98V		FF	-----
1.98 ~ 2.39V		REC/OTR	-----
2.39 ~ 2.90V		-----	-----
2.90 ~ 3.60V		-----	-----
3.60 ~ 4.30V		SENS-INH	-----
4.30 ~ 5.00V		KEY OFF	KEY OFF

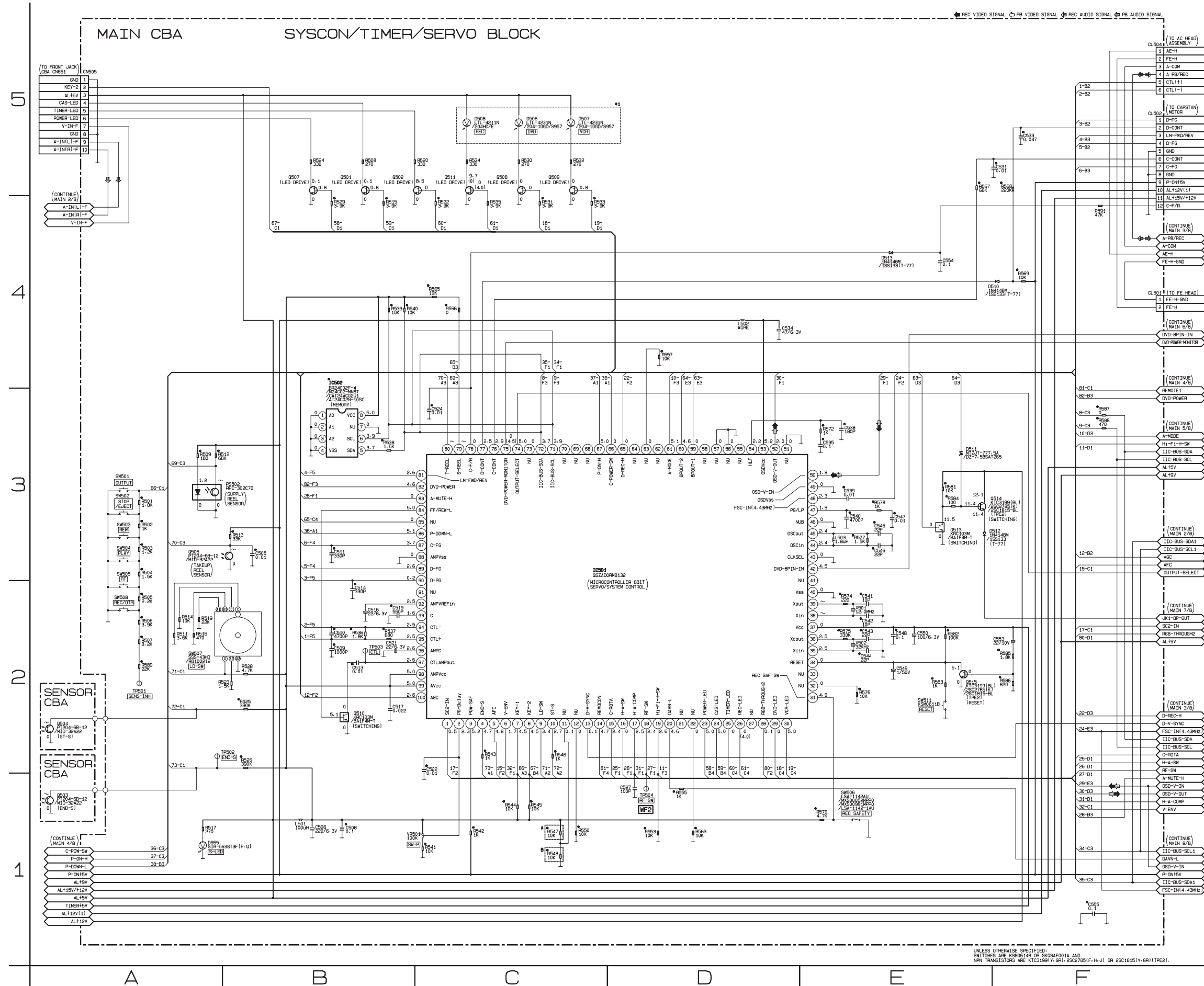

UNLESS OTHERWISE SPECIFIED,
SWITCHES ARE KINGS14B OR 8K50AF001A AND
NPN TRANSISTORS ARE KTC191(Y,GR)-25C2785(F,H,J) OR 25C1815(Y,GR)1PE21.

Main 2/8 Schematic Diagram < VCR Section >

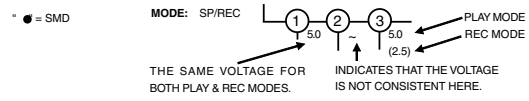

Comparison Chart of Models and Marks

MODEL	MARK
DVD740VR/001	A
DVD740VR/051	B

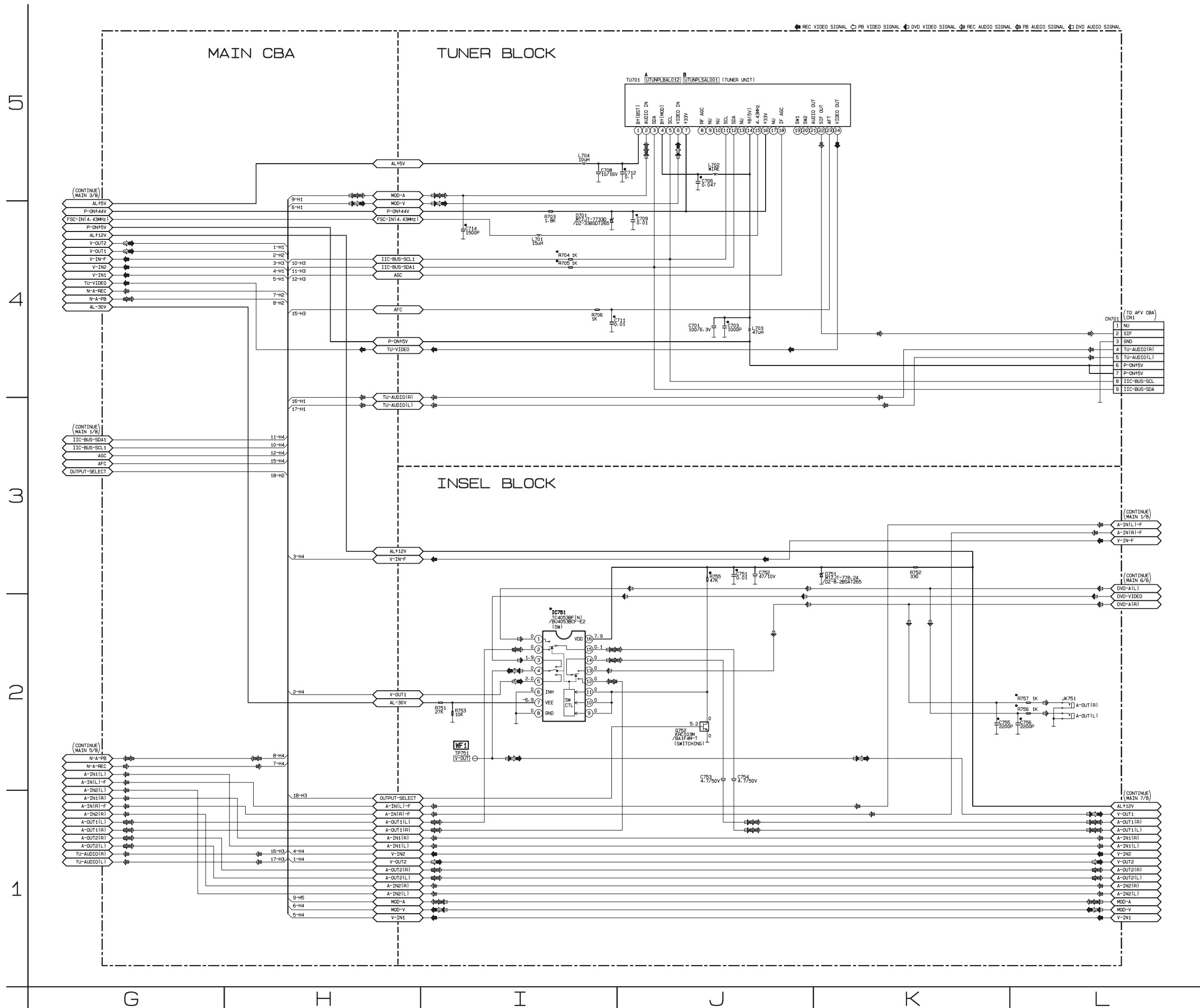

MAIN 2/8 Schematic Diagram Parts Location Guide

Ref No.	Position
CAPACITORS	
C701	J-4
C703	J-4
C706	J-5
C708	I-5
C709	I-4
C711	I-4
C712	J-5
C714	I-4
C751	J-3
C752	J-3
C753	J-2
C754	J-2
C755	K-2
C756	L-2
CONNECTORS	
CN701	L-4
DIODES	
D701	I-4
D751	K-3
ICS	
IC751	I-2
COILS	
L701	I-4
L702	J-5
L703	J-4
L704	I-5
TRANSISTORS	
Q752	J-2
RESISTORS	
R703	I-4
R704	I-4
R705	I-4
R706	I-4
R751	I-2
R752	K-3
R753	I-2
R755	J-3
R756	L-2
R757	L-2
MISCELLANEOUS	
JK751	L-2
TU701	J-5
TEST POINTS	
TP751	I-2

Main 3/8 Schematic Diagram < VCR Section >

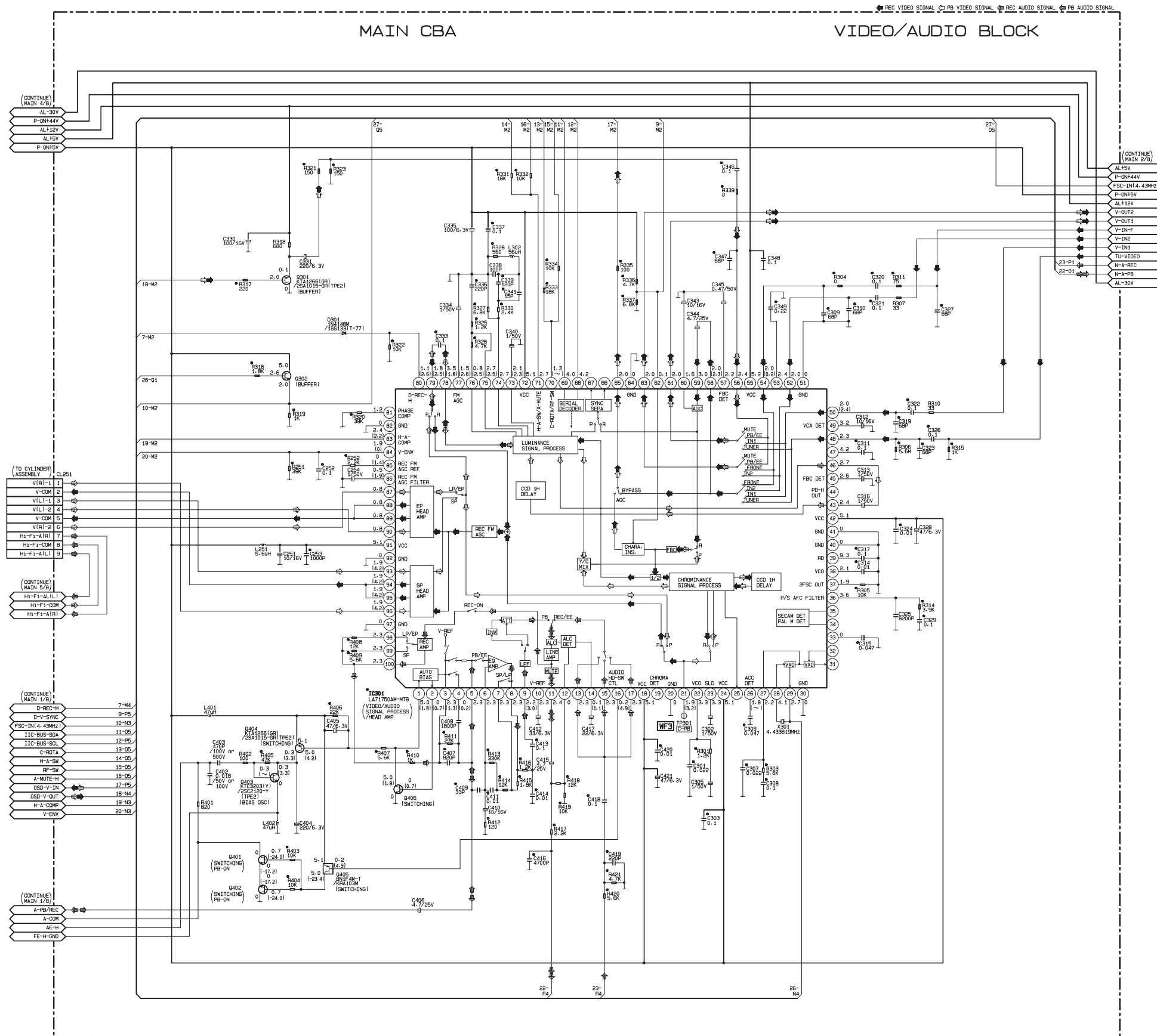
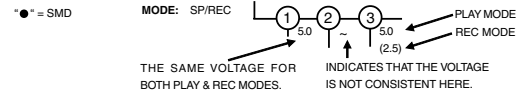

MAIN 3/8 Schematic Diagram Parts Location Guide

Ref No.	Position	Ref No.	Position
CAPACITORS		COILS	
C251	N-3	L251	N-3
C252	N-3	L302	O-4
C253	N-3	L401	N-2
C254	N-3	L402	N-2
C301	P-2	TRANSISTORS	
C302	P-2	Q301	N-4
C303	P-2	Q302	N-4
C305	P-2	Q401	N-1
C306	P-2	Q402	N-1
C307	P-2	Q403	N-2
C308	P-2	Q404	N-2
C309	Q-4	Q405	N-1
C310	Q-4	Q406	O-2
C311	Q-3	RESISTORS	
C312	Q-3	R251	N-3
C313	Q-3	R252	N-3
C314	Q-3	R301	P-2
C315	Q-2	R303	Q-4
C316	Q-3	R304	Q-4
C317	Q-3	R305	Q-3
C319	Q-3	R306	Q-3
C320	Q-4	R307	Q-4
C321	Q-4	R310	Q-4
C322	Q-4	R311	Q-4
C323	Q-3	R314	Q-3
C324	Q-3	R315	Q-3
C325	Q-3	R316	N-4
C326	Q-3	R317	N-4
C327	Q-4	R318	N-4
C328	Q-3	R319	N-3
C329	Q-3	R320	O-3
C330	N-4	R321	N-5
C331	N-4	R322	O-4
C333	O-4	R323	N-5
C334	O-4	R325	O-4
C335	O-4	R326	O-4
C336	O-4	R327	O-4
C337	O-4	R328	O-4
C338	O-4	R330	O-4
C339	O-4	R331	O-5
C340	O-4	R332	O-5
C341	O-4	R333	O-4
C343	P-4	R334	O-4
C344	P-4	R335	P-4
C345	P-4	R336	P-4
C346	P-5	R337	P-4
C347	P-4	R339	P-5
C348	P-4	R401	N-2
C349	P-4	R402	N-1
C402	N-2	R403	N-1
C403	N-2	R404	N-1
C404	N-2	R405	N-2
C405	N-2	R406	N-2
C406	O-1	R407	O-2
C407	O-2	R408	O-2
C408	O-2	R409	O-2
C409	O-2	R410	O-2
C410	O-2	R411	O-2
C411	O-2	R412	O-2
C412	O-2	R413	O-2
C413	O-2	R414	O-2
C414	O-2	R415	O-2
C415	O-2	R416	O-2
C416	O-1	R417	O-2
C417	P-2	R418	O-2
C418	P-2	R419	O-2
C419	P-1	R420	P-1
C420	P-2	R421	P-1
C421	P-2	CRYSTAL OSCILLATORS	
CONNECTORS		X301	P-2
CL251	M-3	TEST POINTS	
DIODES		TP301	P-2
D301	N-4		
ICS			
IC301	O-2		

UNLESS OTHERWISE SPECIFIED:
NPN TRANSISTORS ARE KTC1991(Y,GR), 2SC785(F,H,J) OR 2SC1815-(Y,GR)(TP2).

Main 4/8 Schematic Diagram < VCR Section >

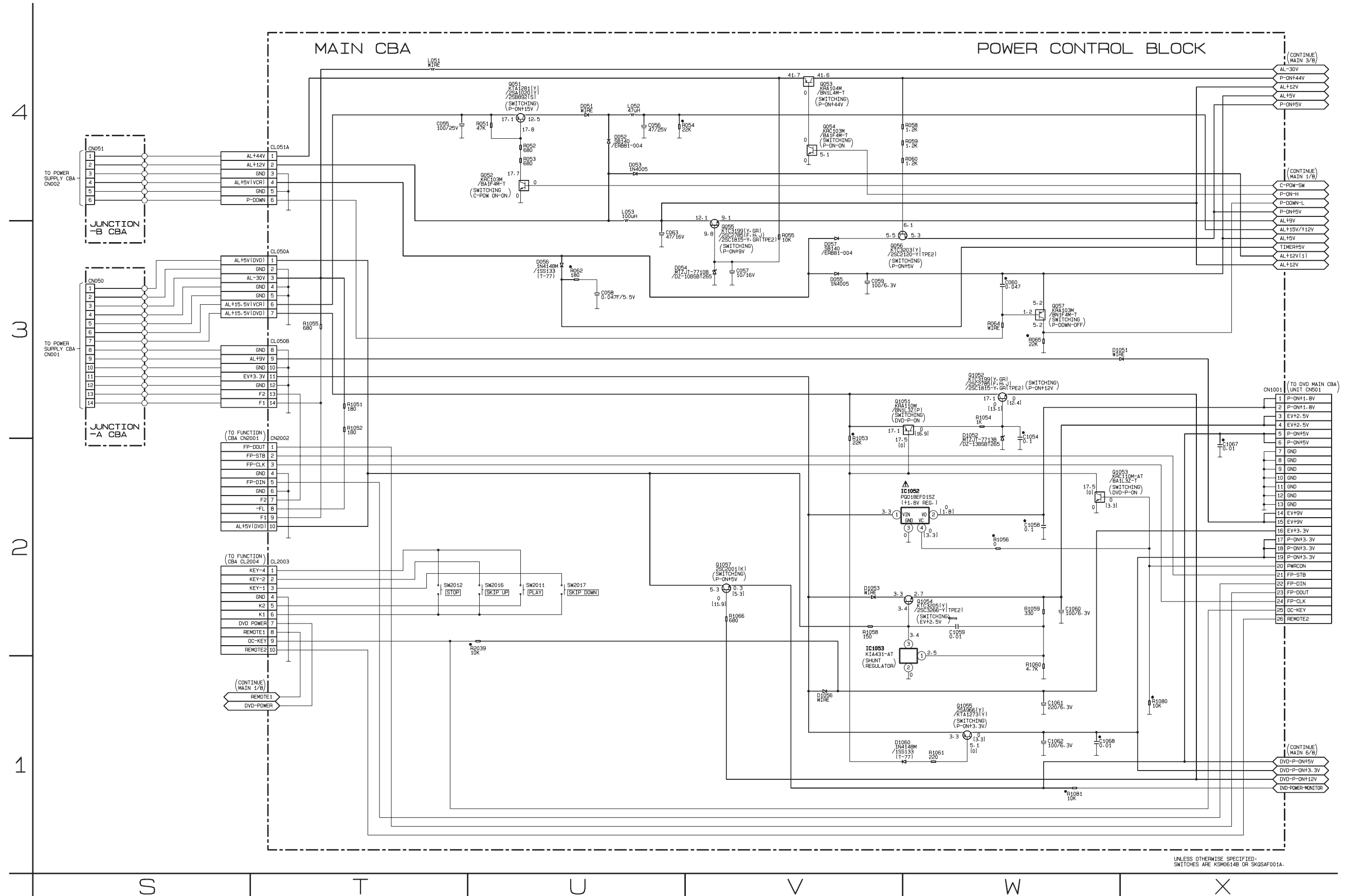
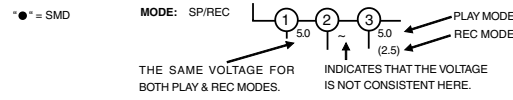

UNLESS OTHERWISE SPECIFIED:
SWITCHES ARE KSM0614B OR SKGSAF001A.

Main 4/8 Schematic Diagram Parts Location Guide

MAIN 4/8 Schematic Diagram Parts Location Guide

Ref No.	Position	Ref No.	Position
CAPACITORS		TRANSISTORS	
C055	T-4	Q051	U-4
C056	U-4	Q052	U-4
C057	V-3	Q053	V-4
C058	U-3	Q054	V-4
C059	V-3	Q055	V-3
C060	W-3	Q056	V-3
C063	U-3	Q057	W-3
C1054	W-3	Q1051	V-3
C1058	W-2	Q1052	W-3
C1059	W-2	Q1053	W-2
C1060	W-2	Q1054	W-2
C1061	W-1	Q1055	W-1
C1062	W-1	Q1057	V-2
C1067	X-2	RESISTORS	
C1068	W-1	R051	U-4
CONNECTORS		R052	U-4
CL051A	T-4	R053	U-4
CL050A	T-3	R054	U-4
CL050B	T-3	R055	V-3
CL2003	T-2	R058	W-4
CN050	S-3	R059	W-4
CN051	S-4	R060	W-4
CN1001	X-3	R062	U-3
CN2002	T-2	R064	W-3
DIODES		R065	W-3
D051	U-4	R1051	T-3
D052	U-4	R1052	T-3
D053	U-4	R1053	V-3
D054	U-3	R1054	W-3
D055	V-3	R1055	T-3
D056	U-3	R1056	W-2
D057	V-3	R1058	V-2
D1051	W-3	R1059	W-2
D1052	W-3	R1060	W-1
D1053	V-2	R1061	W-1
D1056	V-1	R1066	V-2
D1060	V-1	R1080	X-1
ICS		R1081	W-1
IC1052	W-2	R2039	U-2
IC1053	V-2	SWITCHES	
COILS		SW2011	U-2
L051	T-4	SW2012	T-2
L052	U-4	SW2016	U-2
L053	U-4	SW2017	U-2

Main 5/8 Schematic Diagram Parts Location Guide

MAIN 5/8 Schematic Diagram Parts Location Guide

Ref No.	Position	Ref No.	Position
CAPACITORS		CAPACITORS	
C451	Y-2	C488	Z-3
C452	Y-3	ICS	
C453	Y-3	IC451	Y-2
C454	Y-3	COILS	
C455	Y-2	L451	AA-2
C456	Y-2	L452	AA-2
C457	Y-2	TRANSISTORS	
C458	Y-2	Q451	AA-2
C459	Y-2	RESISTORS	
C460	Y-1	R451	Y-2
C461	Z-1	R452	Y-2
C462	Z-1	R453	Y-2
C463	Z-1	R454	Y-2
C464	Z-3	R455	Y-2
C465	Z-1	R456	Y-2
C466	Z-3	R457	Y-2
C467	AA-1	R458	Y-2
C468	Z-3	R459	Y-1
C469	Z-1	R460	Z-1
C470	Z-3	R461	Z-1
C471	Z-1	R462	Z-3
C472	AA-3	R463	Z-1
C473	AA-1	R464	Z-1
C474	AA-1	R465	Z-3
C475	AA-3	R466	Z-3
C476	AA-3	R467	Z-1
C477	AA-2	R468	Z-1
C478	AA-2	R469	Z-3
C479	AA-2	R470	Z-1
C480	AA-2	R471	Z-1
C481	AA-2	R472	Z-1
C482	AA-2	R473	AA-2
C483	AA-3	R475	AA-2
C484	AA-3	R476	AA-2
C487	Z-3		

Main 6/8 Schematic Diagram < VCR Section >

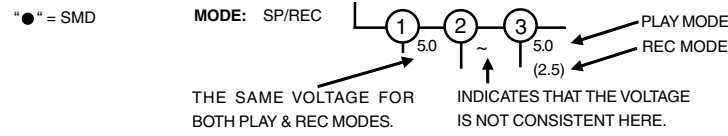

MAIN 6/8 Schematic Diagram Parts Location Guide

Ref No.	Position	Ref No.	Position
CAPACITORS		TRANSISTORS	
C1201	BB-1	Q1501	EE-3
C1202	BB-1	Q1502	EE-3
C1203	BB-1	RESISTORS	
C1204	CC-1	R1201	BB-1
C1205	CC-1	R1202	BB-1
C1206	CC-1	R1203	BB-1
C1207	CC-1	R1204	BB-1
C1208	CC-1	R1205	BB-1
C1221	CC-1	R1206	CC-1
C1222	CC-1	R1207	CC-1
C1245	CC-1	R1208	CC-1
C1246	BB-1	R1209	CC-1
C1247	BB-1	R1210	CC-1
C1249	BB-1	R1211	CC-1
C1351	EE-1	R1212	CC-1
C1352	EE-1	R1221	DD-1
C1353	EE-1	R1222	DD-1
C1354	FF-1	R1223	DD-1
C1356	FF-1	R1224	DD-1
C1391	CC-1	R1225	DD-1
C1401	CC-3	R1226	DD-1
C1421	CC-2	R1235	CC-1
C1422	EE-3	R1236	CC-1
C1441	BB-3	R1237	CC-1
C1442	EE-2	R1238	CC-1
C1445	EE-2	R1239	CC-1
C1461	CC-3	R1240	CC-1
C1462	EE-2	R1245	BB-1
C1471	CC-1	R1246	BB-1
C1481	CC-3	R1247	BB-1
C1482	EE-2	R1352	EE-1
C1486	EE-2	R1353	EE-1
C1523	DD-3	R1354	EE-1
C1531	DD-2	R1355	EE-1
C1532	DD-2	R1356	FF-1
C1534	BB-2	R1360	EE-1
C2058	EE-2	R1364	EE-1
CONNECTORS		R1392	BB-2
CN1601	BB-3	R1393	BB-2
DIODES		R1394	BB-2
D1401	EE-2	R1395	BB-2
D1402	EE-2	R1401	CC-3
D1501	EE-3	R1421	BB-2
ICS		R1422	EE-3
IC1201	CC-1	R1441	BB-3
IC1204	FF-1	R1442	EE-2
IC1402	DD-3	R1461	CC-3
COILS		R1471	CC-3
L1251	FF-1	R1481	BB-3
L1521	DD-2	R1501	EE-3
TRANSISTORS		R1502	EE-3
Q1201	DD-1	R1521	DD-2
Q1202	DD-1	MISCELLANEOUS	
Q1203	DD-1	JK1202	FF-1
Q1204	DD-1	JK1401	FF-2
Q1351	EE-1		

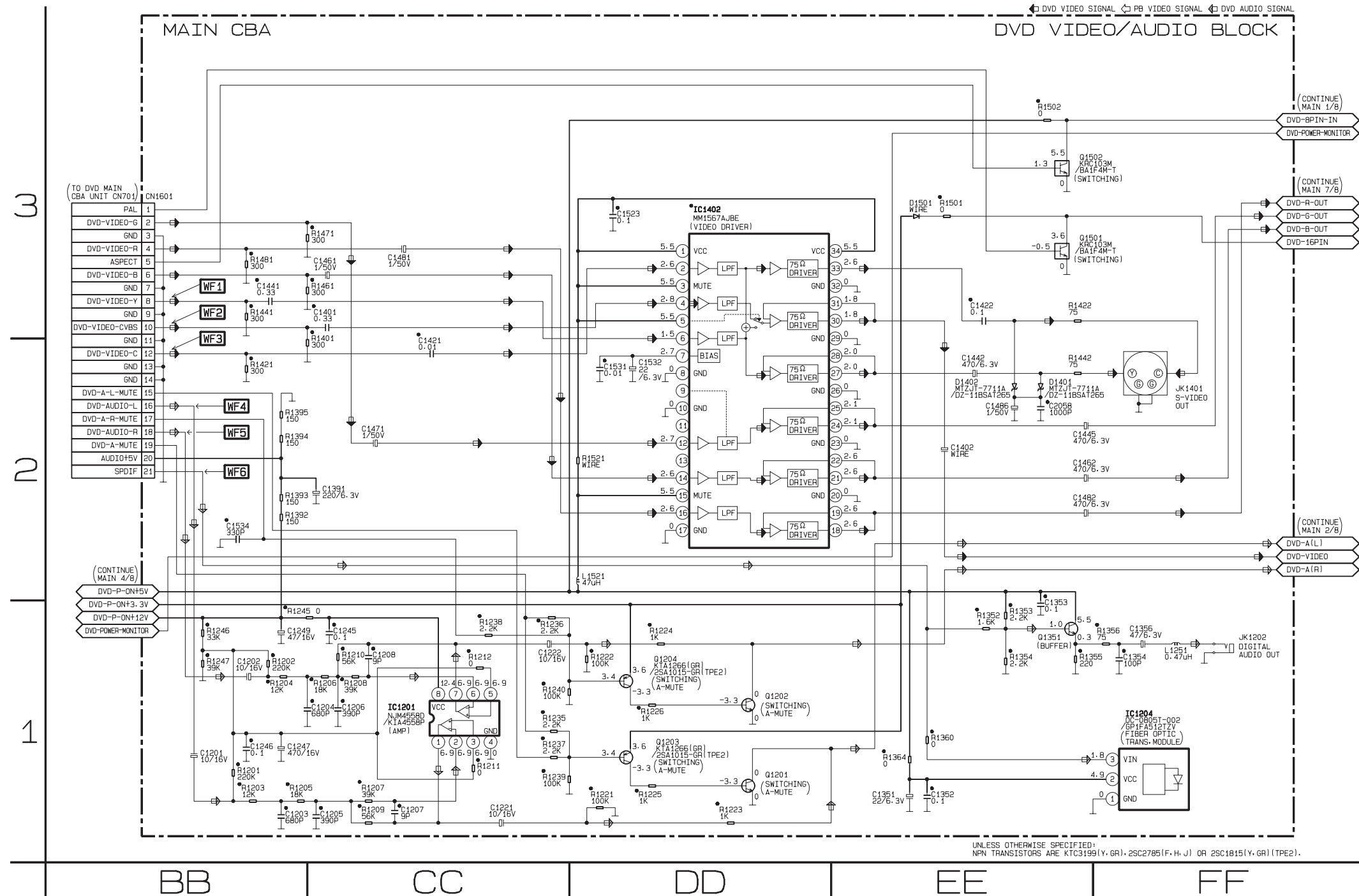

UNLESS OTHERWISE SPECIFIED:
NPN TRANSISTORS ARE KTC3199(Y, GR), 25C2785(F, H, J) OR 25C1815(Y, GR)(TPE2).

Main 7/8 Schematic Diagram < VCR Section >

● = SMD

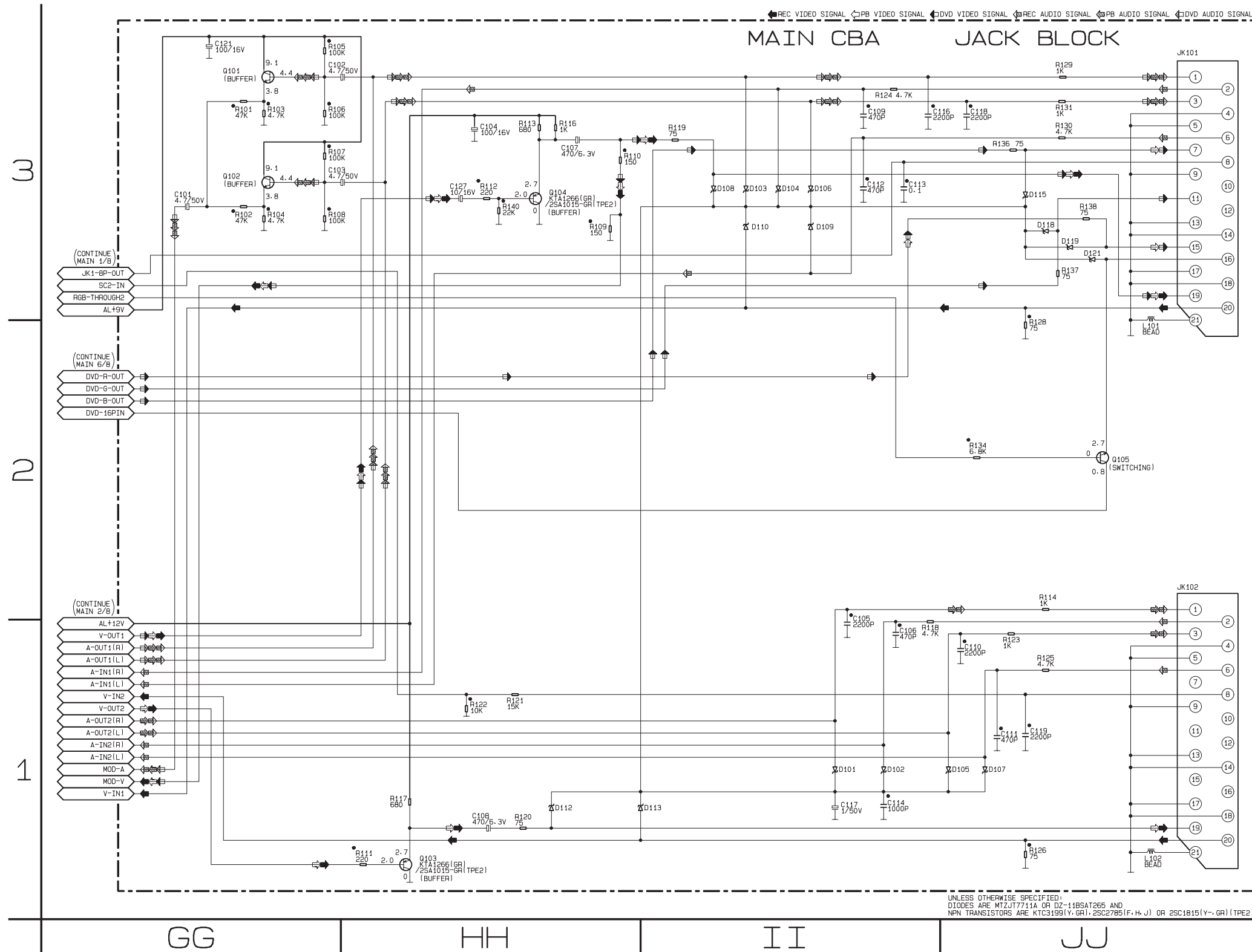
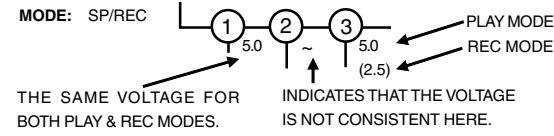

MAIN 7/8 Schematic Diagram Parts Location Guide

Ref No.	Position	Ref No.	Position
CAPACITORS		TRANSISTORS	
C101	GG-3	Q103	HH-1
C102	GG-3	Q104	HH-3
C103	GG-3	Q105	JJ-2
C104	HH-3	RESISTORS	
C105	II-2	R101	GG-3
C106	II-1	R102	GG-3
C107	HH-3	R103	GG-3
C108	HH-1	R104	GG-3
C109	II-3	R105	GG-3
C110	JJ-1	R106	GG-3
C111	JJ-1	R107	GG-3
C112	II-3	R108	GG-3
C113	II-3	R109	HH-3
C114	II-1	R110	HH-3
C116	II-3	R111	HH-1
C117	II-1	R112	HH-3
C118	JJ-3	R113	HH-3
C119	JJ-1	R114	JJ-2
C121	GG-3	R116	HH-3
C127	HH-3	R117	HH-1
DIODES		R118	II-1
D101	II-1	R119	II-3
D102	II-1	R120	HH-1
D103	II-3	R121	HH-1
D104	II-3	R122	HH-1
D105	JJ-1	R123	JJ-1
D106	II-3	R124	II-3
D107	JJ-1	R125	JJ-1
D108	II-3	R126	JJ-1
D109	II-3	R128	JJ-2
D110	II-3	R129	JJ-3
D112	HH-1	R130	JJ-3
D113	II-1	R131	JJ-3
D115	JJ-3	R133	II-2
D118	JJ-3	R134	JJ-2
D119	JJ-3	R136	JJ-3
D121	JJ-3	R137	JJ-3
COILS		R138	JJ-3
L101	JJ-2	R140	HH-3
L102	JJ-1	MISCELLANEOUS	
TRANSISTORS		JK101	JJ-3
Q101	GG-3	JK102	JJ-2
Q102	GG-3		

Main 8/8 Schematic Diagram < VCR Section >

"•" = SMD

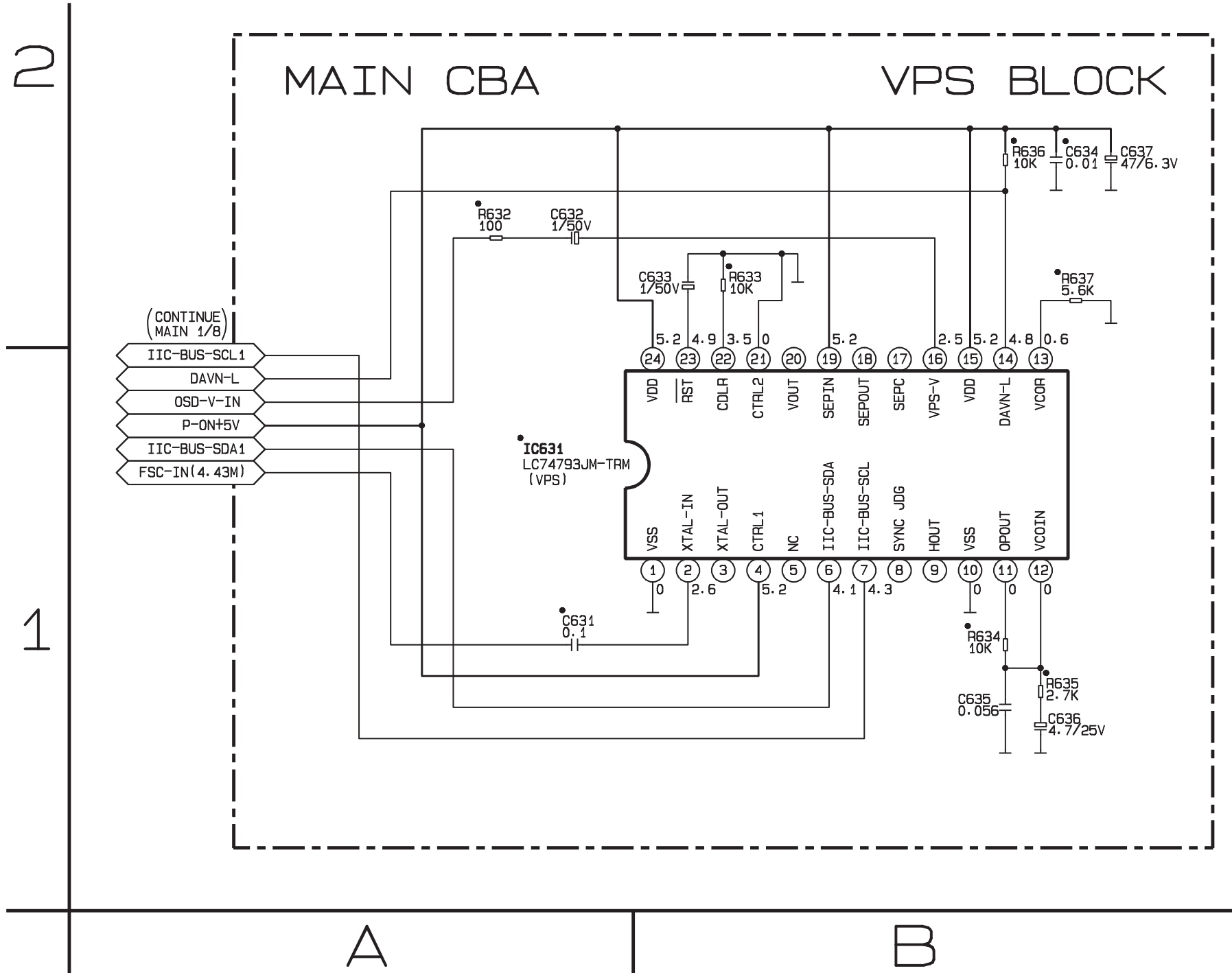
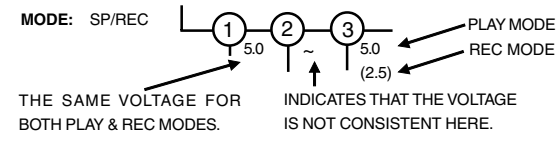

MAIN 8/8 Schematic Diagram
Parts Location Guide

Ref No.	Position
CAPACITORS	
C631	A-1
C632	A-2
C633	B-2
C634	B-2
C635	B-1
C636	B-1
C637	B-2
ICS	
IC631	A-1
RESISTORS	
R632	A-2
R633	B-2
R634	B-1
R635	B-1
R636	B-2
R637	B-2

Power Supply Schematic Diagram < VCR Section >

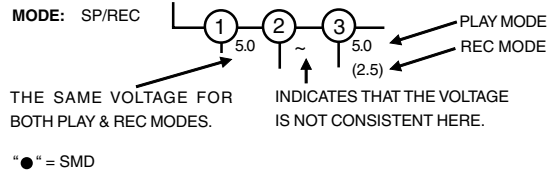

CAUTION!

Fixed voltage (or Auto voltage selectable) power supply circuit is used in this unit. If Main Fuse (F001) is blown, check to see that all components in the power supply circuit are not defective before you connect the AC plug to the AC power supply. Otherwise it may cause some components in the power supply circuit to fail.

NOTE:

THE VOLTAGE FOR PARTS IN HOT CIRCUIT IS MEASURED USING HOT GND AS A COMMON TERMINAL.

CAUTION

FOR CONTINUED PROTECTION AGAINST FIRE HAZARD, REPLACE ONLY WITH THE SAME TYPE FUSE.

Comparison Chart of Models and Marks

MODEL	MARK
DVD740VR/001	A
DVD740VR/051	B

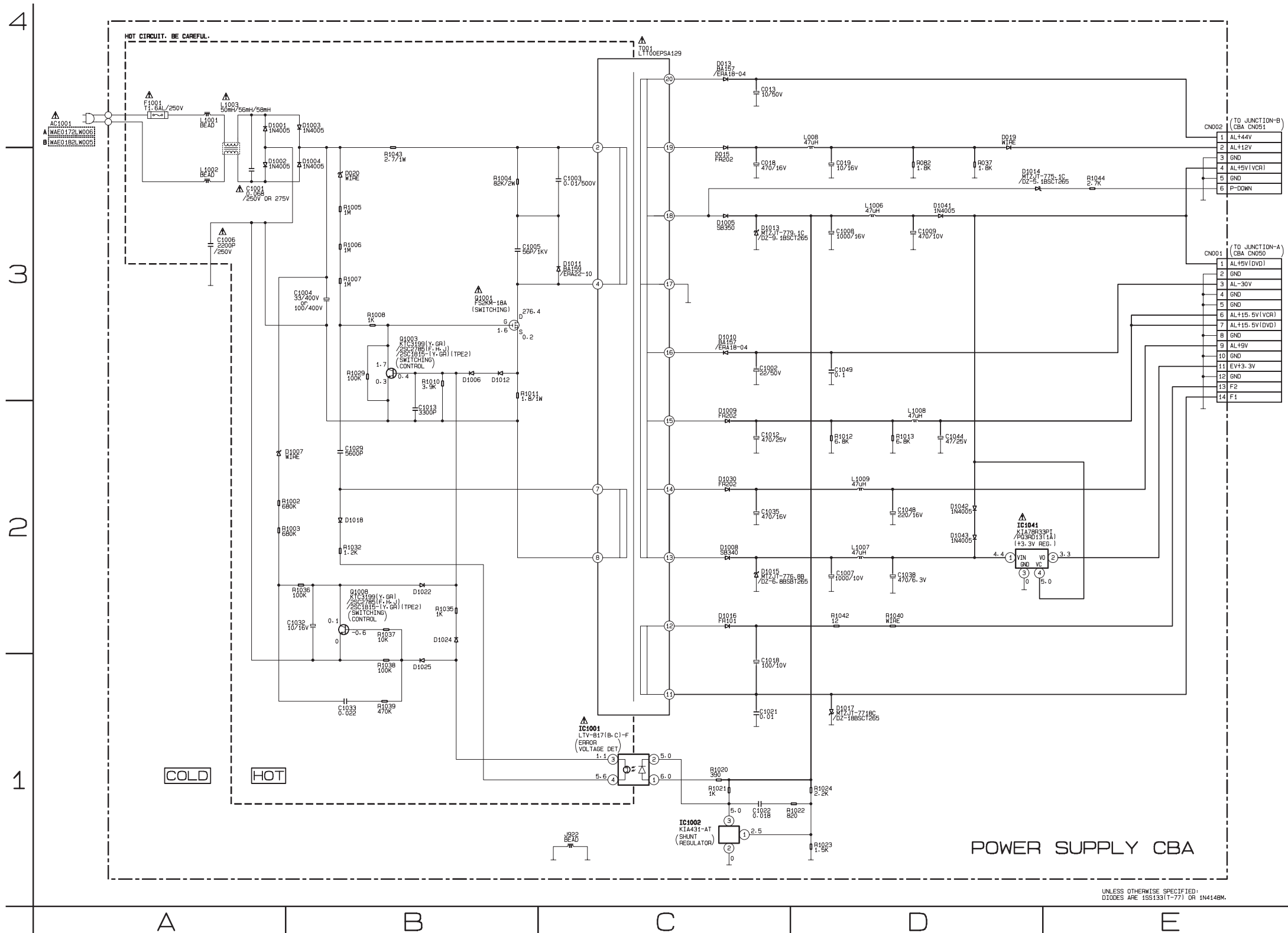

Power Supply Schematic Diagram Parts Location Guide

Ref No.	Position	Ref No.	Position
CAPACITORS		DIODES	
C013	C-4	D1041	D-3
C018	C-3	D1042	D-2
C019	D-3	D1043	D-2
C1001	A-3	ICS	
C1002	C-3	IC1001	C-1
C1003	C-3	IC1002	C-1
C1004	B-3	IC1041	D-2
C1005	B-3	COILS	
C1006	A-3	J922	C-1
C1007	D-2	L008	D-4
C1008	D-3	L1001	A-4
C1009	D-3	L1002	A-3
C1012	C-2	L1003	A-4
C1013	B-2	L1006	D-3
C1018	C-1	L1007	D-2
C1021	C-1	L1008	D-2
C1022	C-1	L1009	D-2
C1029	B-2	TRANSISTORS	
C1032	B-2	Q1001	B-3
C1033	B-1	Q1003	B-3
C1035	C-2	Q1008	B-2
C1038	D-2	RESISTORS	
C1044	D-2	R037	D-3
C1048	D-2	R082	D-3
C1049	D-3	R1002	A-2
CONNECTORS		R1003	A-2
CN001	E-3	R1004	B-3
CN002	E-4	R1005	B-3
DIODES		R1006	B-3
D013	C-4	R1007	B-3
D015	C-3	R1008	B-3
D019	D-4	R1010	B-3
D020	B-3	R1011	B-3
D1001	A-4	R1012	D-2
D1002	A-3	R1013	D-2
D1003	B-4	R1020	C-1
D1004	B-3	R1021	C-1
D1005	C-3	R1022	C-1
D1006	B-3	R1023	D-1
D1007	B-2	R1024	D-1
D1008	C-2	R1029	B-3
D1009	C-2	R1032	B-2
D1010	C-3	R1035	B-2
D1011	C-3	R1036	B-2
D1012	B-3	R1037	B-2
D1013	C-3	R1038	B-1
D1014	D-3	R1039	B-1
D1015	C-2	R1040	D-2
D1016	C-2	R1042	D-2
D1017	D-1	R1043	B-3
D1018	B-2	R1044	E-3
D1022	B-2	MISCELLANEOUS	
D1024	B-2	AC1001	A-4
D1025	B-1	F1001	A-4
D1030	C-2	T001	C-4

Function Schematic Diagram < VCR Section >

• = SMD

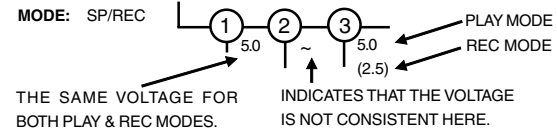

FL2001 MATRIX CHART

	7G	6G	5G	4G	3G	2G	1G
a	STANDBY	a	a	a	a	a	①
b	REPEAT	b	b	b	b	b	②
c	A	c	c	c	c	c	③
d	B	d	d	d	d	d	④
e	▶	e	e	e	e	e	⑤
f	⏸	f	f	f	f	f	DVD
g	—	g	g	g	g	g	PBC
h	—	⏮	TITLE	⏭	CHP.	TRK.	CD
i	—	—	□	—	—	—	V

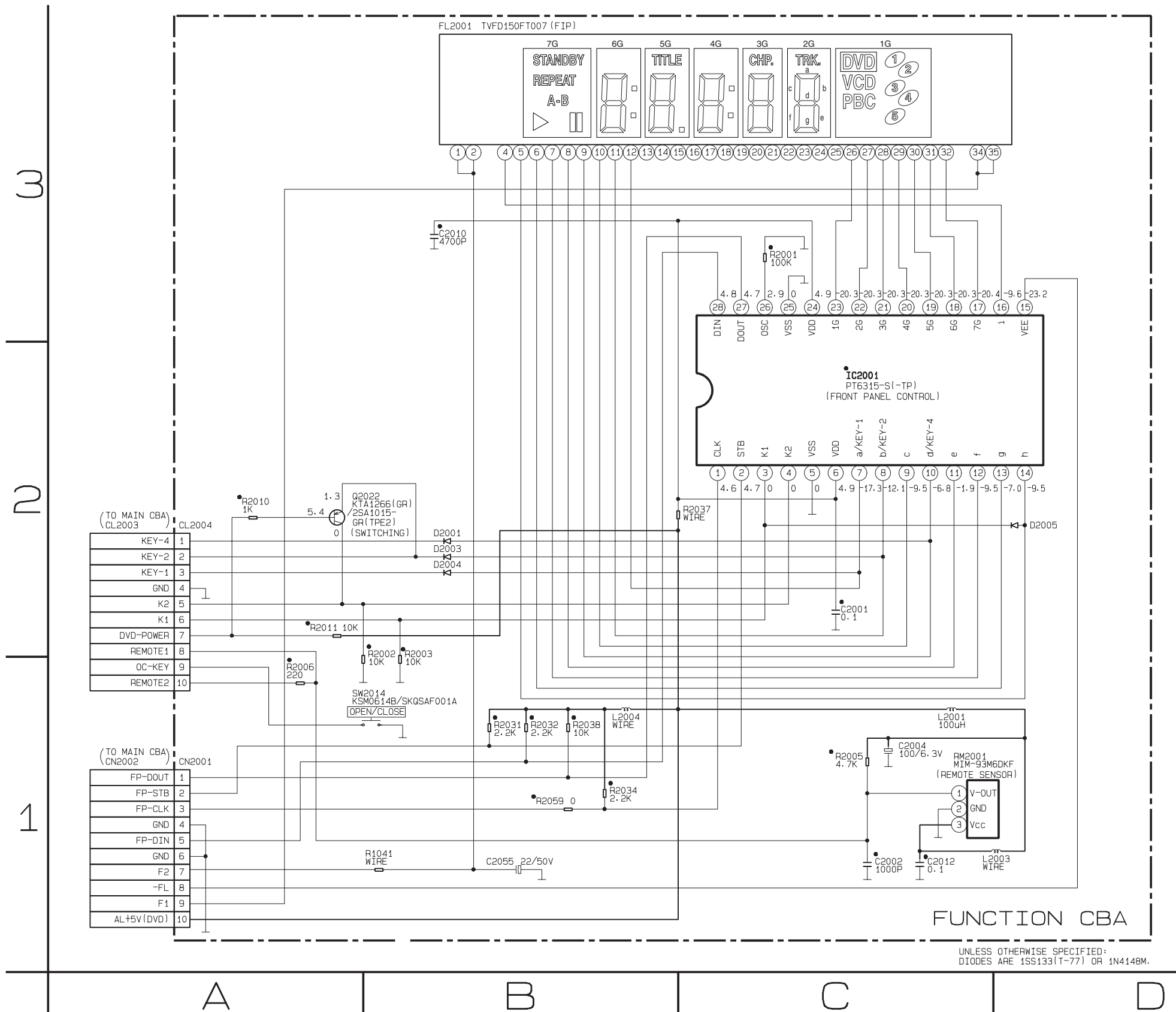

Function Schematic Diagram
Parts Location Guide

Ref No.	Position
CAPACITORS	
C2001	C-2
C2002	C-1
C2004	C-1
C2010	B-3
C2012	C-1
C2055	B-1
CONNECTORS	
CL2004	A-2
CN2001	A-1
DIODES	
D2001	B-2
D2003	B-2
D2004	B-2
D2005	D-2
IC	
IC2001	C-2
COILS	
L2001	C-1
L2003	C-1
L2004	B-1
TRANSISTOR	
Q2022	A-2
RESISTORS	
R1041	B-1
R2001	C-3
R2002	B-2
R2003	B-2
R2005	C-1
R2006	A-1
R2010	A-2
R2031	B-1
R2032	B-1
R2034	B-1
R2037	C-2
R2038	B-1
R2059	B-1
SWITCH	
SW2014	A-1
MISCELLANEOUS	
FL2001	B-3
RM2001	C-1

UNLESS OTHERWISE SPECIFIED:
DIODES ARE 1SS133(T-77) OR 1N4148M.

Front Jack Schematic Diagram < VCR Section >

***2 Note:**

When it is necessary to replace one or more of the following Diodes, all four should be replaced: D652, D653, D654, D655.

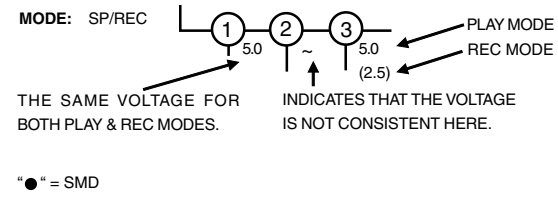

"●" = SMD

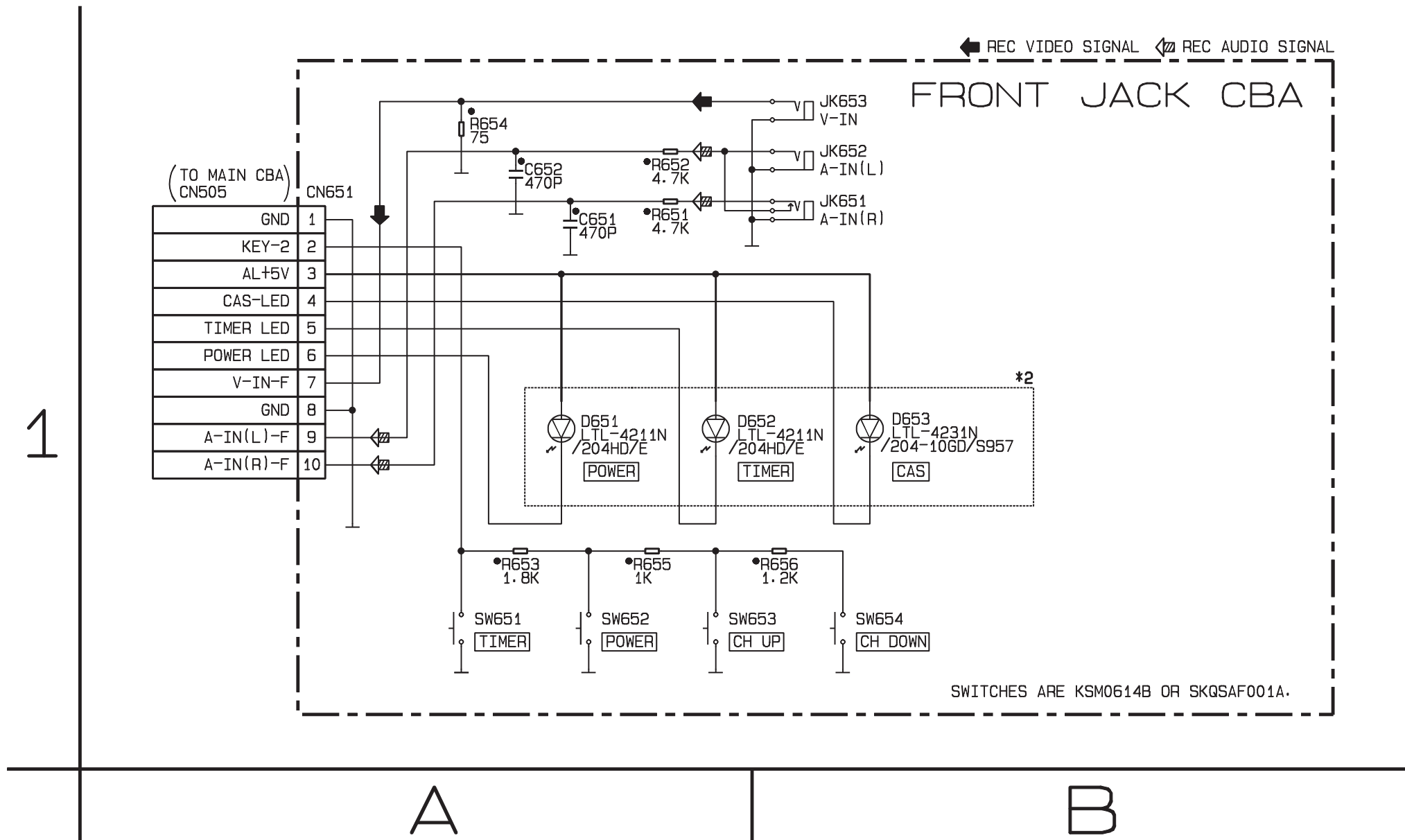

Front Jack Schematic Diagram
Parts Location Guide

Ref No.	Position
CAPACITORS	
C651	A-1
C652	A-1
CONNECTOR	
CN651	A-1
DIODES	
D651	A-1
D652	A-1
D653	B-1
RESISTORS	
R651	A-1
R652	A-1
R653	A-1
R654	A-1
R655	A-1
R656	B-1
SWITCHES	
SW651	A-1
SW652	A-1
SW653	A-1
SW654	B-1
MISCELLANEOUS	
JK651	B-1
JK652	B-1
JK653	B-1

AFV Schematic Diagram < VCR Section >

"●" = SMD

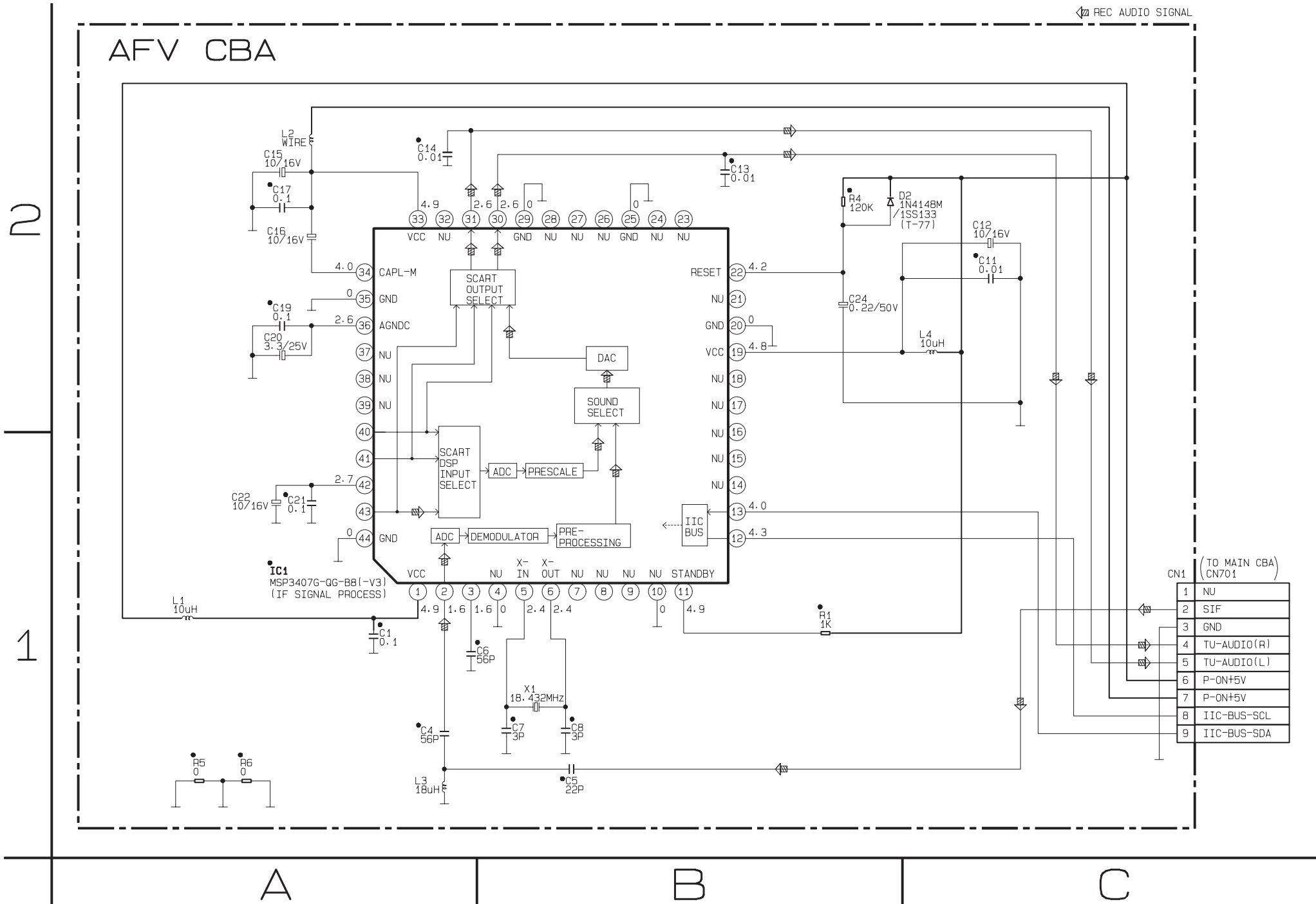
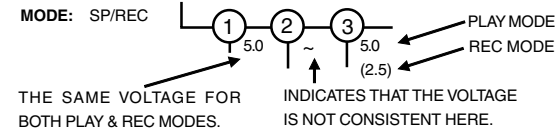

AFV Schematic Diagram
Parts Location Guide

Ref No.	Position
CAPACITORS	
C1	A-1
C4	A-1
C5	B-1
C6	B-1
C7	B-1
C8	B-1
C11	C-2
C12	C-2
C13	B-2
C14	A-2
C15	A-2
C16	A-2
C17	A-2
C19	A-2
C20	A-2
C21	A-1
C22	A-1
C24	B-2
CONNECTOR	
CN1	C-1
DIODE	
D2	B-2
IC	
IC1	A-1
COILS	
L1	A-1
L2	A-2
L3	A-1
L4	C-2
RESISTORS	
R1	B-1
R4	B-2
R5	A-1
R6	A-1
CRYSTAL OSCILLATOR	
X1	B-1

Main CBA Parts Location Guide

Ref No.	Position	Ref No.	Position	Ref No.	Position	Ref No.	Position	Ref No.	Position	Ref No.	Position	Ref No.	Position	Ref No.	Position	Ref No.	Position	Ref No.	Position	Ref No.	Position
CAPACITORS		CAPACITORS		CAPACITORS		CAPACITORS		DIODES		COILS		RESISTORS		RESISTORS		RESISTORS		RESISTORS		RESISTORS	
C055	B-4	C336	C-3	C481	C-4	C1058	B-3	D053	B-2	L452	C-3	R058	A-2	R327	C-3	R507	A-1	R589	A-1	R1360	A-5
C056	B-4	C337	C-3	C482	C-3	C1059	A-3	D054	A-2	L501	B-1	R059	A-2	R328	C-3	R508	G-2	R591	F-1	R1364	B-5
C057	A-2	C338	C-3	C483	C-3	C1060	A-3	D055	B-3	L502	C-1	R060	A-2	R330	C-3	R509	C-2	R632	B-2	R1392	A-4
C058	B-2	C339	C-3	C484	C-3	C1061	A-3	D056	B-3	L503	C-2	R062	B-2	R331	C-3	R511	F-1	R633	B-1	R1393	A-4
C059	B-3	C340	C-3	C487	C-3	C1062	A-3	D057	B-3	L701	F-4	R064	B-3	R332	C-3	R512	C-1	R634	C-1	R1394	A-4
C060	B-3	C341	C-3	C488	C-3	C1067	A-2	D101	E-5	L702	G-5	R065	B-2	R333	C-2	R513	E-1	R635	C-1	R1395	A-4
C063	A-2	C343	C-3	C505	D-2	C1068	A-2	D102	E-5	L703	G-4	R101	C-5	R334	C-2	R514	F-1	R636	B-1	R1401	A-5
C101	C-5	C344	D-3	C506	B-1	C1201	B-4	D103	C-5	L704	F-5	R102	C-5	R335	C-3	R515	G-2	R637	C-1	R1421	A-5
C102	C-5	C345	D-3	C508	B-1	C1202	B-5	D104	D-5	L1251	B-5	R103	C-5	R336	C-3	R516	F-1	R703	G-5	R1422	B-5
C103	C-5	C346	D-3	C509	E-1	C1203	B-4	D105	E-5	L1521	A-5	R104	C-5	R337	C-3	R517	D-2	R704	F-2	R1441	A-5
C104	E-5	C347	D-3	C510	E-1	C1204	B-5	D106	D-5	TRANSISTORS		R105	C-5	R339	D-3	R519	F-1	R705	F-2	R1442	B-5
C105	E-5	C348	D-3	C511	E-1	C1205	B-4	D107	E-5	Q051	B-4	R106	C-5	R401	E-4	R520	G-2	R706	G-3	R1461	A-5
C106	E-5	C349	D-3	C513	D-1	C1206	B-5	D108	D-5	Q052	B-4	R107	C-5	R402	D-4	R522	G-2	R751	B-4	R1471	A-5
C107	E-5	C402	D-4	C514	E-1	C1207	B-4	D109	D-5	Q053	A-1	R108	C-5	R403	E-4	R523	F-1	R752	C-4	R1481	A-5
C108	F-5	C403	D-4	C516	D-1	C1208	B-4	D110	E-5	Q054	B-2	R109	E-5	R404	E-4	R524	G-2	R753	C-4	R1501	B-5
C109	D-5	C404	D-4	C517	D-1	C1221	B-4	D112	F-5	Q055	A-2	R110	E-5	R405	C-4	R525	F-1	R755	C-4	R1502	A-5
C110	E-5	C405	D-4	C519	D-1	C1222	B-4	D113	F-5	Q056	A-2	R111	F-5	R406	D-4	R526	D-1	R756	C-5	R1521	B-5
C111	E-5	C406	E-4	C521	D-1	C1245	B-5	D115	D-5	Q057	B-3	R112	E-5	R407	D-4	R528	F-1	R757	C-5	R2039	A-1
C112	D-5	C407	D-4	C522	D-1	C1246	A-4	D118	D-5	Q101	C-5	R113	E-5	R408	D-3	R529	G-2	R1051	A-4	SWITCHES	
C113	D-5	C408	D-4	C524	E-2	C1247	A-4	D119	D-5	Q102	C-5	R114	E-5	R409	D-3	R530	C-1	R1052	A-4	SW501	D-1
C114	F-5	C409	D-4	C527	C-1	C1249	B-4	D121	E-5	Q103	F-5	R116	E-5	R410	D-4	R531	C-1	R1053	B-3	SW502	D-1
C116	D-5	C410	D-4	C531	E-1	C1351	A-5	D301	C-3	Q104	E-5	R117	F-5	R411	D-4	R532	D-1	R1054	A-3	SW503	E-1
C117	F-5	C411	D-3	C533	E-2	C1352	B-5	D506	C-1	Q105	F-5	R118	E-5	R412	E-4	R533	C-1	R1055	A-4	SW504	E-1
C118	C-5	C412	D-3	C534	C-1	C1353	B-5	D507	D-1	Q301	F-4	R119	D-5	R413	D-4	R534	F-1	R1056	B-3	SW505	E-1
C119	E-5	C413	D-3	C535	C-1	C1354	B-5	D508	F-1	Q302	D-3	R120	F-5	R414	D-3	R535	E-1	R1058	A-3	SW506	C-1
C121	C-5	C414	D-4	C538	C-2	C1356	B-5	D510	E-2	Q401	E-4	R121	F-5	R415	D-3	R536	E-1	R1059	A-3	SW507	F-1
C127	E-5	C415	D-3	C539	D-2	C1391	A-4	D511	C-2	Q402	E-4	R122	F-5	R416	D-3	R537	E-1	R1060	B-3	SW508	E-1
C251	C-3	C416	B-3	C540	D-2	C1401	B-5	D512	C-2	Q403	C-4	R123	E-5	R417	D-3	R538	D-1	R1061	A-3	SW511	B-2
C252	C-3	C417	E-3	C541	C-1	C1421	B-5	D513	F-1	Q404	D-4	R124	D-5	R418	D-3	R539	E-2	R1066	B-4	SW2011	C-1
C253	D-3	C418	D-3	C542	C-1	C1422	B-5	D555	D-2	Q405	E-4	R125	E-5	R419	D-4	R540	E-2	R1080	A-2	SW2012	B-1
C254	C-3	C419	E-4	C543	C-1	C1441	B-5	D701	G-5	Q406	D-3	R126	F-5	R420	E-4	R541	G-2	R1081	A-2	SW2016	C-1
C301	D-3	C420	D-3	C544	C-1	C1442	B-5	D751	C-4	Q451	C-3	R128	D-5	R421	E-4	R542	F-1	R1201	B-4	SW2017	B-1
C302	D-3	C421	D-3	C545	D-2	C1445	D-5	D1051	A-3	Q501	G-2	R129	C-5	R451	B-3	R543	D-1	R1202	A-4	VARIABLE RESISTORS	
C303	E-3	C451	B-3	C546	D-2	C1461	B-5	D1052	A-3	Q502	G-2	R130	D-5	R452	C-3	R544	D-1	R1203	C-4	VR501	G-2
C305	D-3	C452	C-3	C547	D-2	C1462	C-5	D1053	A-3	Q506	D-2	R131	C-5	R453	B-3	R545	F-1	R1204	B-5	CRYSTAL OSCILLATORS	
C306	E-3	C453	C-3	C548	C-1	C1471	B-5	D1056	A-3	Q507	G-2	R133	F-5	R454	C-3	R546	C-1	R1205	C-4	X301	E-3
C307	E-3	C454	C-3	C549	C-1	C1481	B-5	D1060	A-3	Q508	C-1	R134	F-5	R455	B-3	R547	C-1	R1206	B-5	X501	C-1
C308	D-3	C455	B-3	C550	C-1	C1482	D-5	D1401	B-5	Q509	C-1	R136	D-5	R456	B-3	R548	C-1	R1207	B-4	X502	C-1
C309	D-2	C456	B-3	C553	C-1	C1486	B-5	D1402	B-5	Q510	E-1	R137	D-5	R457	B-3	R550	C-1	R1208	B-5	MISCELLANEOUS	
C310	D-3	C457	B-3	C554	E-2	C1523	B-5	D1501	B-5	Q511	E-1	R138	D-5	R458	B-3	R553	C-1	R1209	B-4	JK101	E-5
C311	D-2	C458	B-3	C555	E-2	C1531	C-5	ICS		Q513	C-2	R140	E-5	R459	B-3	R555	B-1	R1210	B-5	JK102	E-5
C312	D-3	C459	B-3	C631	B-1	C1532	C-5	IC301	D-3	Q514	C-2	R251	C-3	R460	B-3	R557	E-2	R1211	B-4	JK751	C-5
C313	D-3	C460	B-3	C632	B-1	C1534	A-5	IC451	C-3	Q515	C-1	R252	C-3	R461	B-3	R563	C-1	R1212	B-5	JK1202	B-5
C314	E-3	C461	B-3	C633	B-1	C2058	B-5	IC501	D-1	Q752	C-4	R301	D-3	R462	C-3	R565	E-2	R1221	B-5	JK1401	B-5
C315	E-3	C462	B-3	C634	B-1	CONNECTORS		IC502	D-2	Q1051	B-3	R303	E-3	R463	B-3	R566	E-2	R1222	C-5	PS502	C-2
C316	D-3	C463	C-3	C635	C-1	CL051A	B-3	IC631	B-1	Q1052	A-4	R304	D-2	R464	B-3	R567	E-1	R1223	B-4	TU701	G-4
C317	E-3	C464	C-3	C636	C-1	CL050A	A-4	IC751	C-4	Q1053	A-3	R305	E-3	R465	C-3	R568	E-2	R1224	B-4	TEST POINTS	
C319	D-2	C465	C-3	C637	B-1	CL050B	A-4	IC1052	B-3	Q1054	A-3	R306	D-2	R466	C-3	R569	E-1	R1225	B-4	TP301	F-4
C320	D-2	C466	C-3	C701	G-4	CL251	C-3	IC1053	B-3	Q1055	A-3	R307	D-3	R467	B-3	R570	C-1	R1226	B-5	TP501	B-1
C321	D-3	C467	C-3	C703	G-4	CL501	C-4	IC1201	B-4	Q1057	B-3	R310	E-3	R468	B-3	R572	C-2	R1235	A-5	TP502	B-2
C322	D-2	C468	C-3	C706	G-5	CL502	F-2	IC1204	A-5	Q1201	B-4	R311	D-2	R469	C-3	R574	C-1	R1236	A-5	TP503	G-2
C323	E-3	C469	C-4	C708	F-5	CL504	E-4	IC1402	B-5	Q1202	B-4	R314	E-3	R470	C-4	R575	C-1	R1237	A-4	TP504	B-2
C324	E-3	C470	C-3	C709	G-5	CL506	A-1	COILS		Q1203	A-4	R315	E-3	R471	B-4	R576	C-1	R1238	A-5	TP751	E-4
C325	E-3	C471	C-4	C711	G-3	CL508	E-4	L051	A-4	Q1204	B-4	R316	E-3	R472	B-4	R577	D-2	R1239	A-4		
C326	E-3	C472	C-3	C712	G-5	CL2003	A-1	L052	B-4	Q1351	A-5	R317	E-4	R473	C-3	R578	D-2	R1240	A-5		
C327	D-2	C473	C-3	C714	G-5	CN505	G-3	L053	B-2	Q1501	A-5	R318	E-4	R475	C-4	R581	C-2	R1245	B-5		
C328	D-3	C474	C-4	C751	C-4	CN701	G-3	L101	E-5	Q1502	A-4	R319	E-3	R476	C-3	R582	C-2	R1246	B-5		
C329	E-3	C475	C-3	C752	C-4	CN1001	A-2	L102	F-5	RESISTORS		R320	C-3	R501	D-1	R583	C-2	R1247	A-4		
C330	F-4	C476	C-3	C753	C-4	CN1601	A-5	L251	C-3	R051	B-4	R321	D-2	R502	D-1	R584	C-2	R1352	A-5		
C331	F-4	C477	C-4	C754	C-4	CN2002	A-3	L302	C-3	R052	B-4	R322	C-3	R503	E-1	R585	C-2	R1353	A-5		
C333	C-3	C478	C-4	C755	C-5	DIODES		L401	E-3	R053	B-4	R323	D-2	R504	E-1	R586	C-2	R1354	A-5		
C334	C-3	C479	C-3	C756	C-5	D051	B-4	L402	C-4	R054	B-4	R325	C-3	R505	E-1	R587	C-3	R1355	B-5		
C335	C-3	C480	C-3	C1054	A-3	D052	B-4	L451	C-3	R055	A-2	R326	C-3	R506	B-1	R588	C-3	R1356	B-5		

Main CBA Bottom View

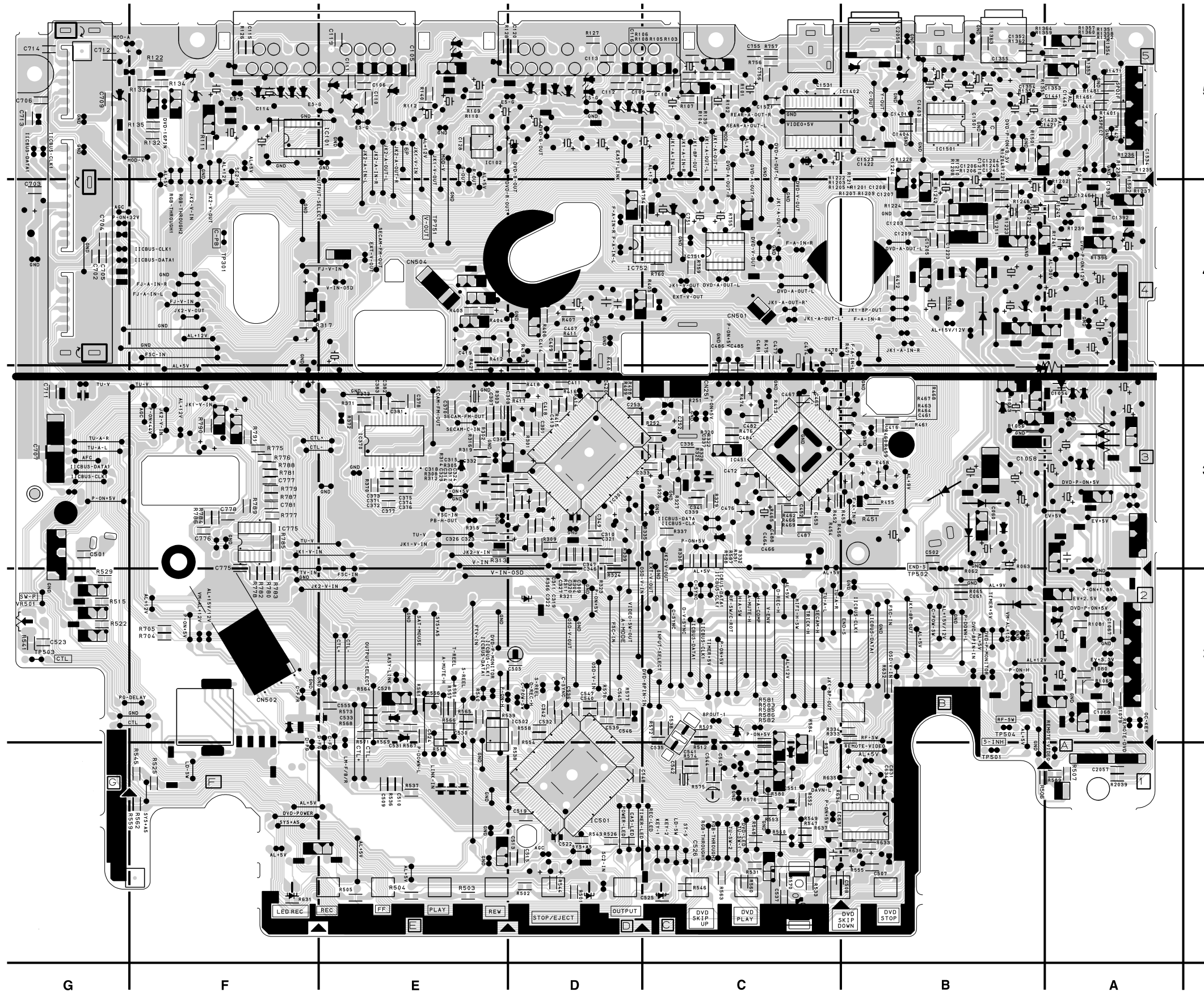

POWER SUPPLY CBA Parts Location Guide

Ref No.	Position	Ref No.	Position
CAPACITORS			
C013	C-2	D1041	A-3
C018	C-2	D1042	A-3
C019	C-2	D1043	C-3
C1001	B-1	ICs	
C1002	C-2	IC1001	B-1
C1003	B-2	IC1002	C-1
C1004	A-2	IC1041	B-3
C1005	B-2	COILS	
C1006	A-3	J922	A-3
C1007	C-1	L008	C-2
C1008	C-2	L1001	A-1
C1009	C-3	L1002	A-2
C1012	C-2	L1003	A-1
C1013	B-1	L1006	C-2
C1018	C-1	L1007	C-1
C1021	C-1	L1008	C-1
C1022	C-1	L1009	C-1
C1029	B-2	TRANSISTORS	
C1032	B-1	Q1001	B-2
C1033	B-1	Q1003	B-1
C1035	C-2	Q1008	B-1
C1038	C-1	RESISTORS	
C1044	C-2	R037	C-2
C1048	C-1	R082	C-3
C1049	C-2	R1002	B-1
CONNECTORS			
CN001	A-3	R1003	B-1
CN002	A-3	R1004	B-3
DIODES			
D013	C-2	R1005	B-2
D015	C-2	R1006	B-1
D019	A-3	R1007	B-1
D020	B-2	R1008	B-1
D1001	A-2	R1010	B-1
D1002	A-2	R1011	B-2
D1003	A-2	R1012	C-2
D1004	A-2	R1013	C-1
D1005	C-2	R1020	C-1
D1006	B-1	R1021	C-1
D1007	B-2	R1022	C-1
D1008	C-1	R1023	C-1
D1009	C-2	R1024	C-1
D1010	C-2	R1029	B-1
D1011	B-2	R1032	B-1
D1012	B-2	R1035	B-1
D1013	C-2	R1036	B-1
D1014	C-2	R1037	B-1
D1015	C-1	R1038	B-1
D1016	C-1	R1039	B-1
D1017	C-1	R1040	C-1
D1018	B-1	R1042	C-1
D1019	B-1	R1043	B-3
D1020	B-1	R1044	A-3
D1022	B-1	MISCELLANEOUS	
D1024	B-1	AC1001	A-2
D1025	B-1	F1001	B-2
D1030	C-2	T001	A-2

Power Supply CBA Top View

CAUTION!
 Fixed voltage (or Auto voltage selectable) power supply circuit is used in this unit.
 If Main Fuse (F001) is blown, check to see that all components in the power supply circuit are not defective before you connect the AC plug to the AC power supply.
 Otherwise it may cause some components in the power supply circuit to fail.

NOTE:
 The voltage for parts in hot circuit is measured using hot GND as a common terminal.

Power Supply CBA Bottom View

BECAUSE A HOT CHASSIS GROUND IS PRESENT IN THE POWER SUPPLY CIRCUIT , AN ISOLATION TRANSFORMER MUST BE USED. ALSO , IN ORDER TO HAVE THE ABILITY TO INCREASE THE INPUT SLOWLY , WHEN TROUBLESHOOTING THIS TYPE POWER SUPPLY CIRCUIT , A VARIABLE ISOLATION TRANSFORMER IS REQUIRED.

CAUTION
 FOR CONTINUED PROTECTION AGAINST FIRE HAZARD, REPLACE ONLY WITH THE SAME TYPE FUSE.

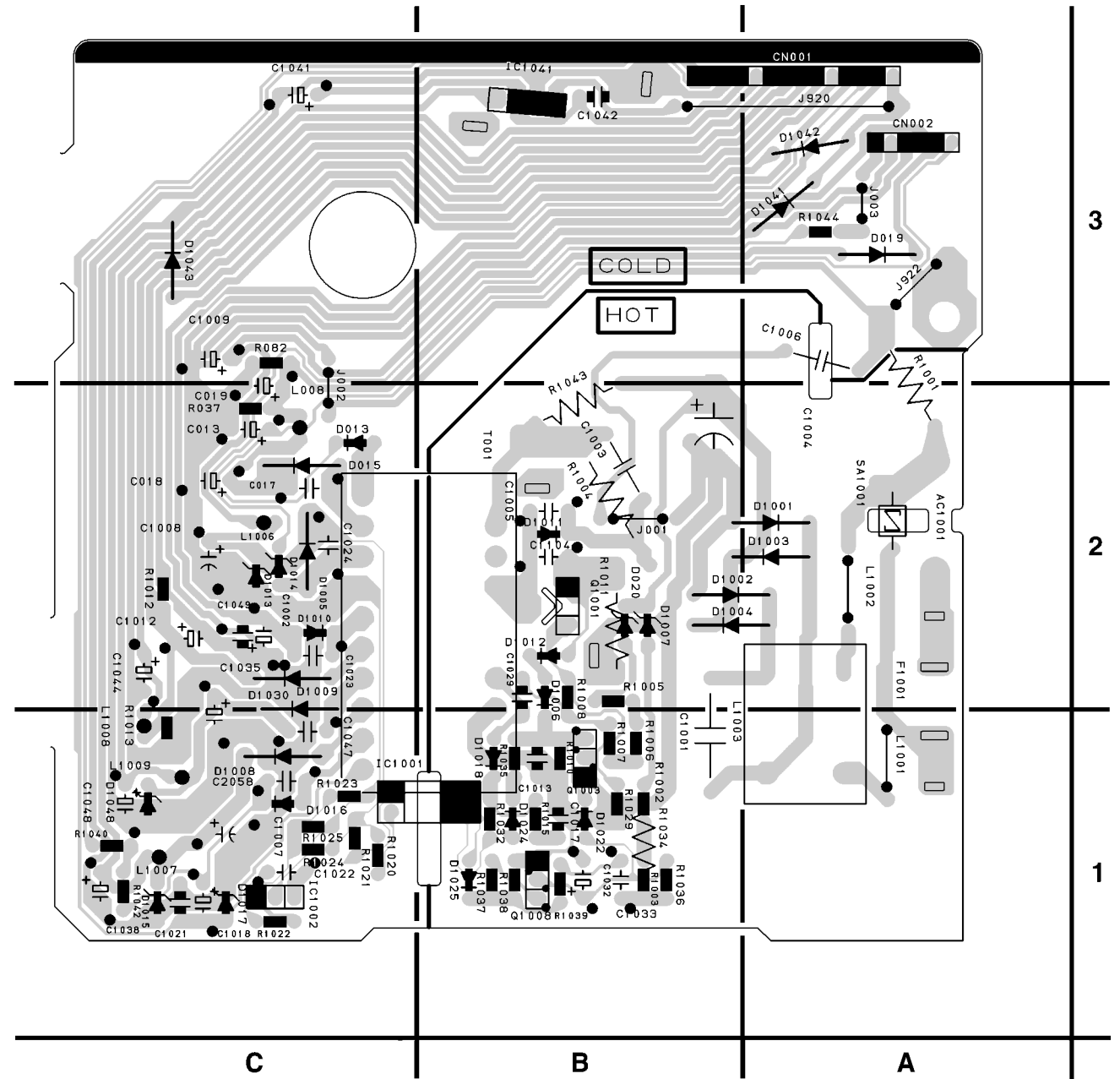
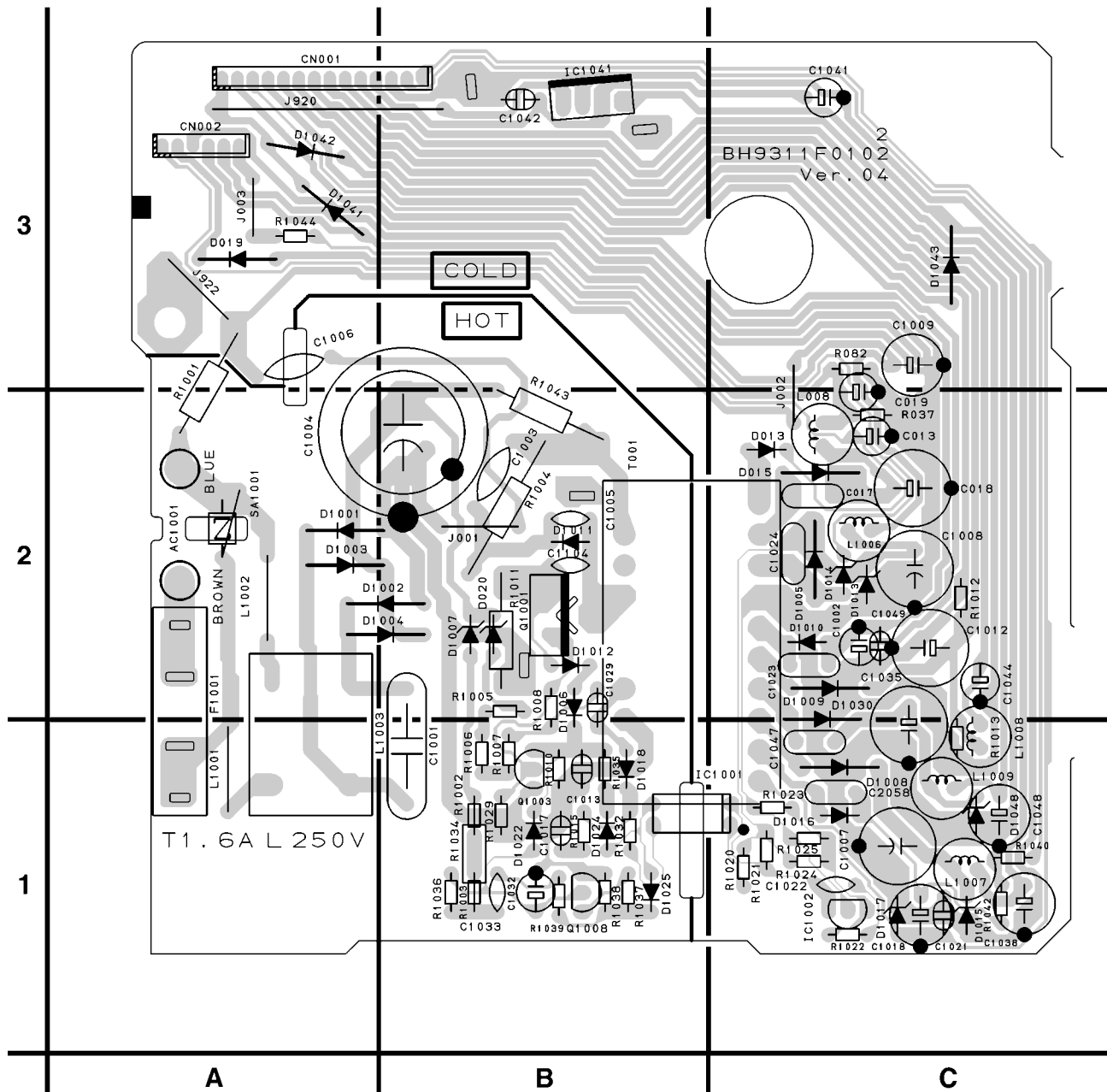

Function CBA Top View

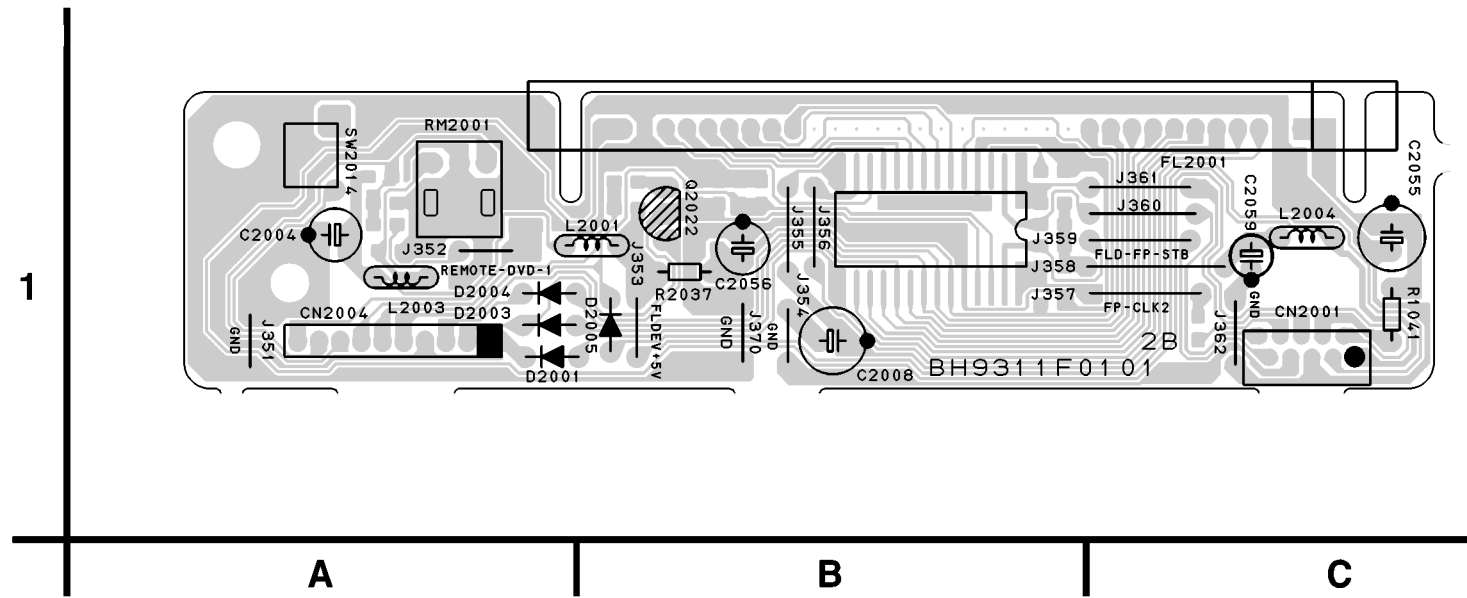

Function CBA Bottom View

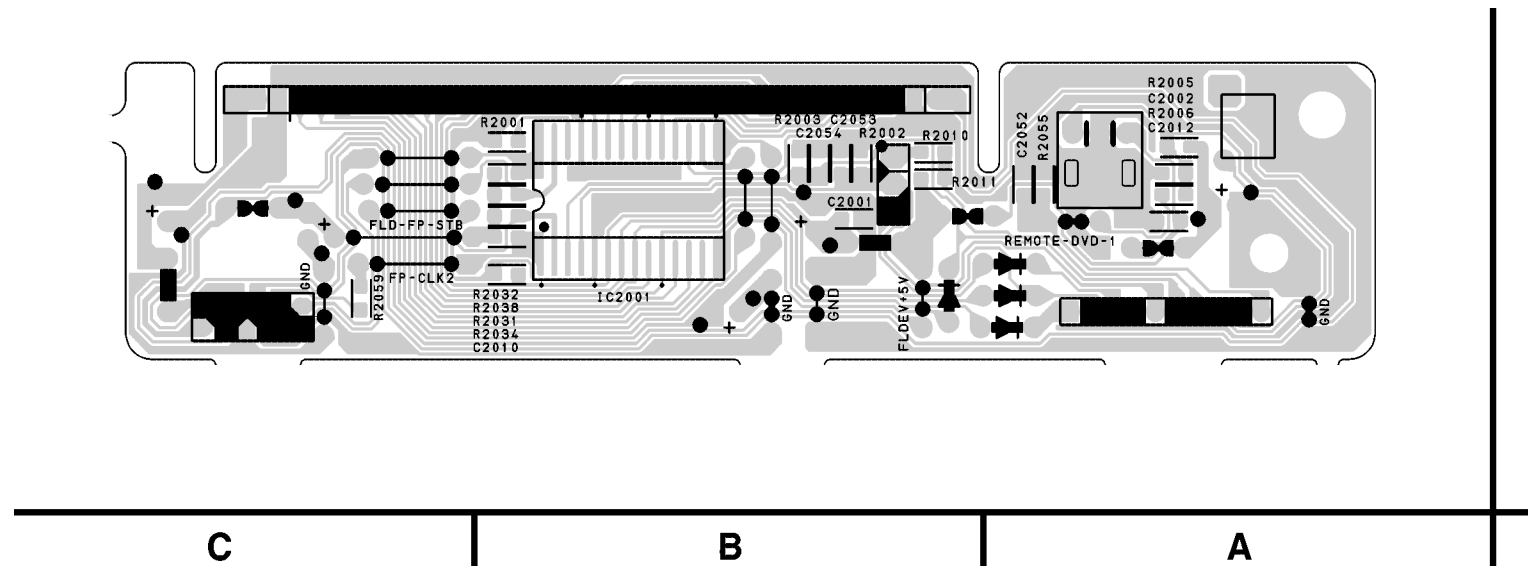

FUNCTION CBA
Parts Location Guide

Ref No.	Position
CAPACITORS	
C2001	B-1
C2002	A-1
C2004	A-1
C2010	B-1
C2012	A-1
C2055	C-1
CONNECTORS	
CL2004	A-1
CN2001	C-1
DIODES	
D2001	A-1
D2003	A-1
D2004	A-1
D2005	B-1
IC	
IC2001	B-1
COILS	
L2001	A-1
L2003	A-1
L2004	C-1
TRANSISTOR	
Q2022	B-1
RESISTORS	
R1041	C-1
R2001	B-1
R2002	B-1
R2003	B-1
R2005	A-1
R2006	A-1
R2010	B-1
R2011	B-1
R2031	B-1
R2032	B-1
R2034	B-1
R2037	B-1
R2038	B-1
R2059	C-1
SWITCH	
SW2014	A-1
MISCELLANEOUS	
FL2001	C-1
RM2001	A-1

BH9311F01012-B

Front Jack CBA Top View

Front Jack CBA Bottom View

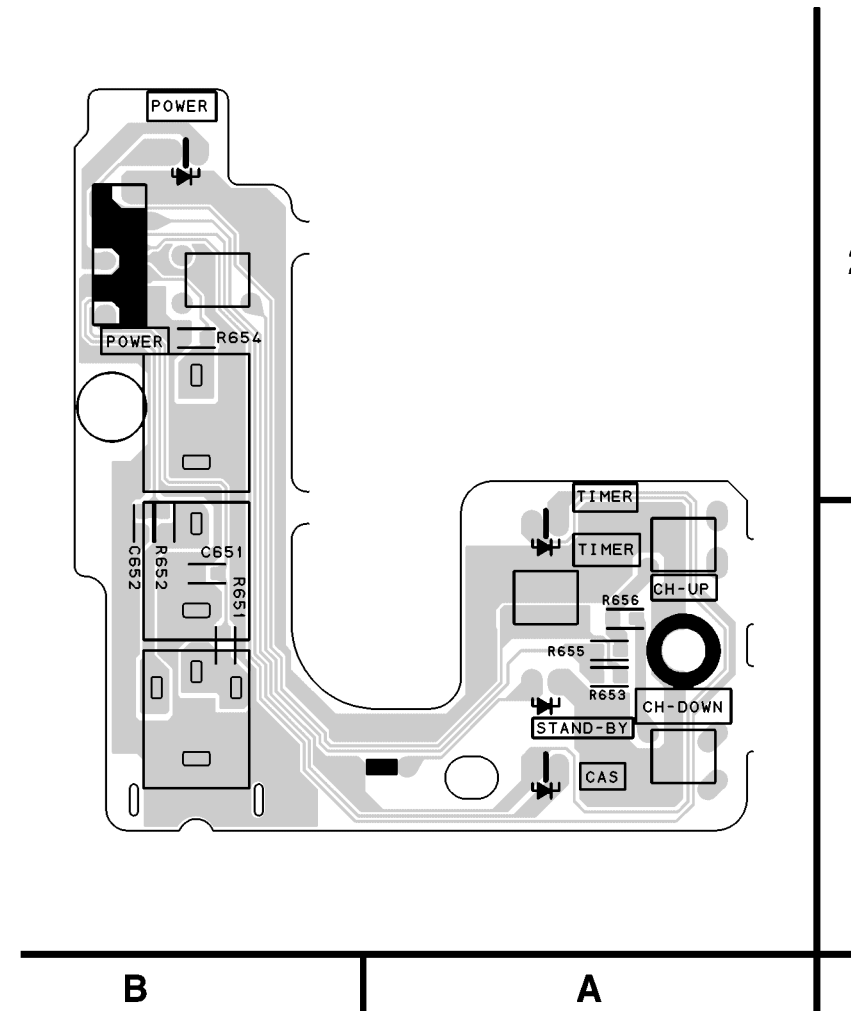
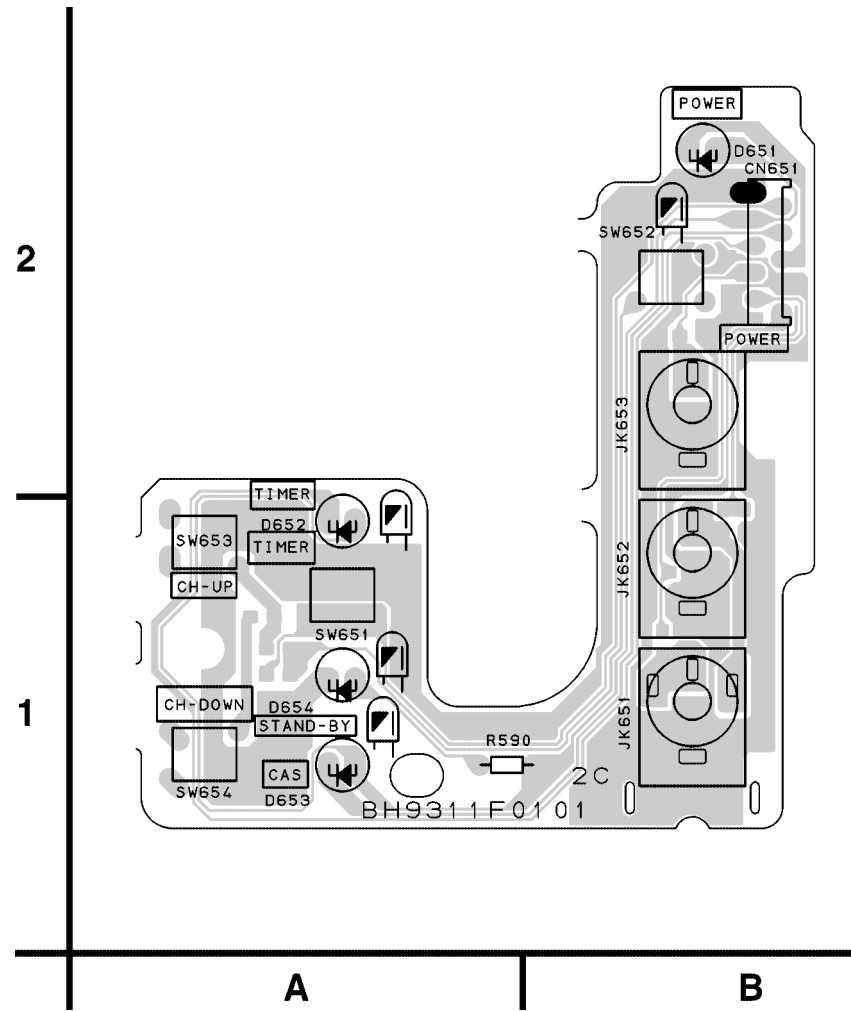

FRONT JACK CBA
Parts Location Guide

Ref No.	Position
CAPACITORS	
C651	B-1
C652	B-1
CONNECTOR	
CN651	B-2
DIODES	
D651	B-2
D652	A-1
D653	A-1
RESISTORS	
R651	B-1
R652	B-1
R653	A-1
R654	B-2
R655	A-1
R656	A-1
SWITCHES	
SW651	A-1
SW652	B-2
SW653	A-1
SW654	A-1
MISCELLANEOUS	
JK651	B-1
JK652	B-1
JK653	B-2

BH9311F01012-C

AFV CBA Top View

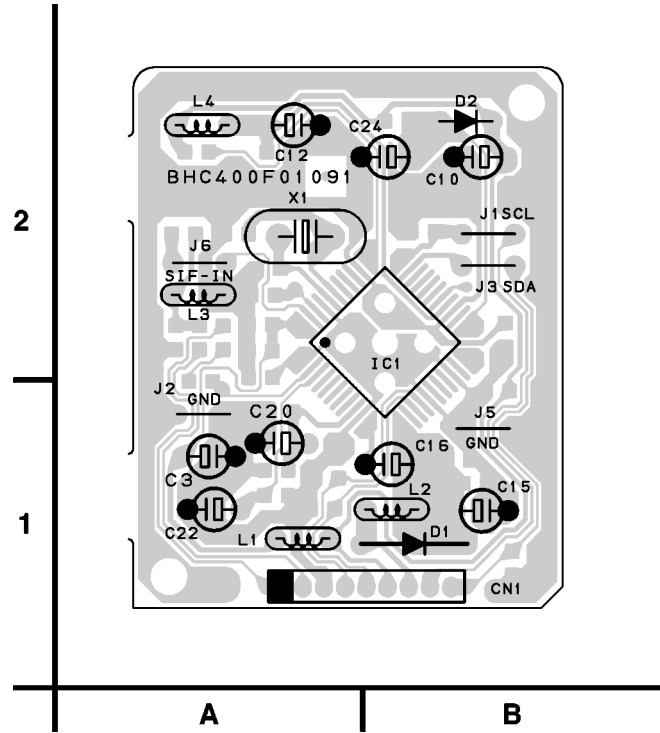

AFV CBA Bottom View

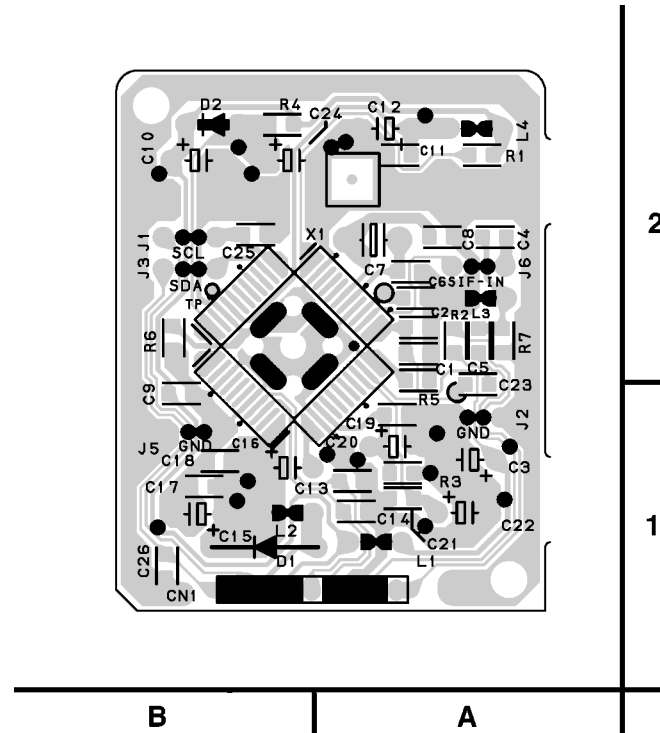

BHC400F01091

AFV CBA Parts Location Guide

Ref No.	Position	Ref No.	Position	Ref No.	Position
CAPACITORS		CAPACITORS		COILS	
C1	A-2	C17	B-1	L1	A-1
C4	A-2	C19	A-1	L2	B-1
C5	A-2	C20	A-1	L3	A-2
C6	A-2	C21	A-1	L4	A-2
C7	A-2	C22	A-1	RESISTORS	
C8	A-2	C24	A-2	R1	A-2
C11	A-2	CONNECTOR		R4	B-2
C12	A-2	CN1	B-1	R5	A-1
C13	B-1	DIODE		R6	B-2
C14	A-1	D2	B-2	CRYSTAL OSCILLATOR	
C15	B-1	IC		X1	A-2
C16	B-1	IC1	B-2		

Junction-A CBA Top View

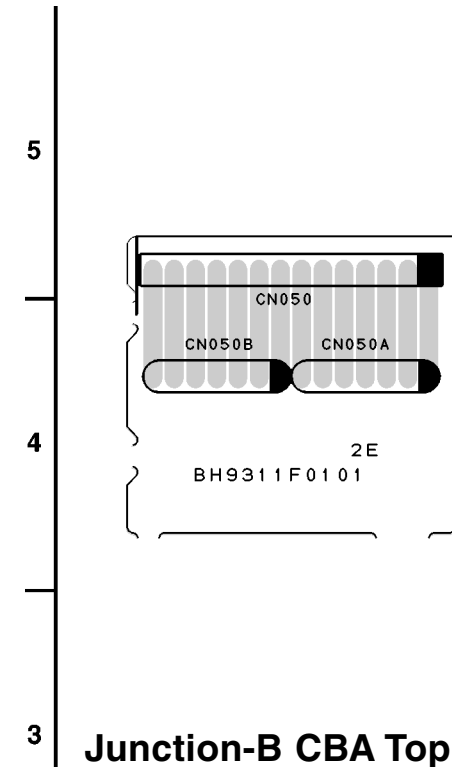

Junction-A CBA Bottom View

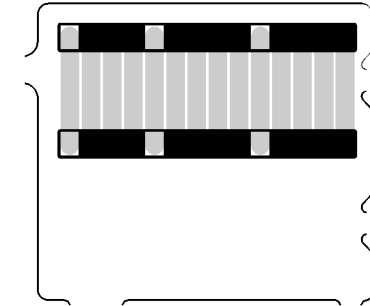

BH9311F01012-E

Junction-B CBA Top View

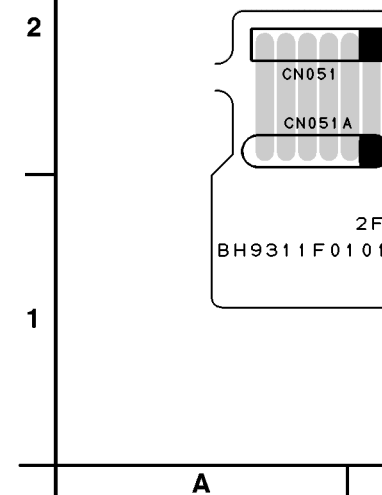

Junction-B CBA Bottom View

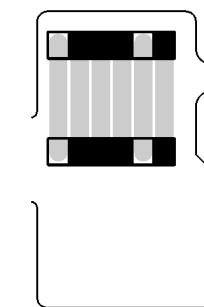

BH9311F01012-F

• = SMD
MODE: SP/REC 1 2 3
PLAY MODE
REC MODE
THE SAME VOLTAGE FOR BOTH PLAY & REC MODES.
INDICATES THAT THE VOLTAGE IS NOT CONSISTENT HERE.

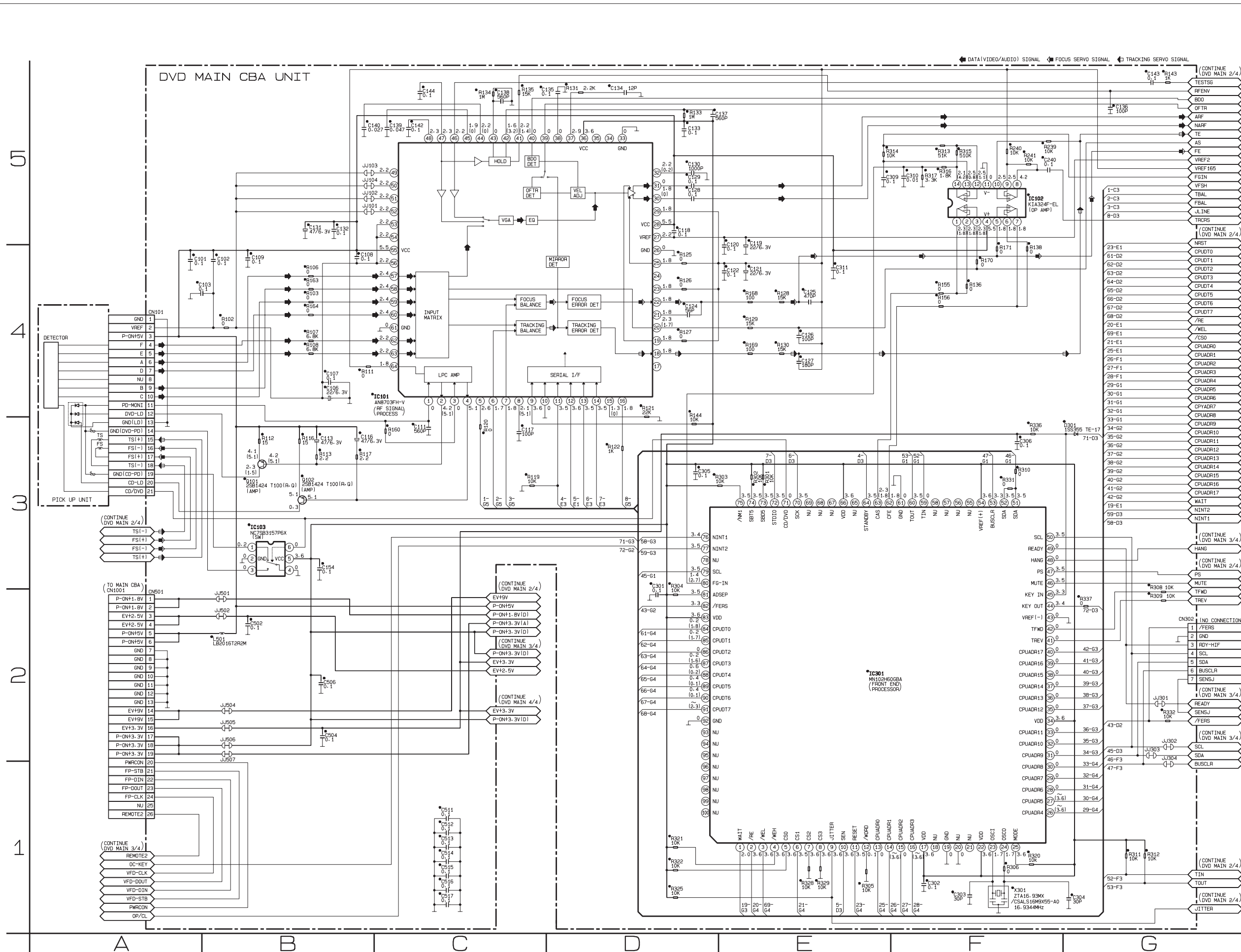

DVD Main 2/4 Schematic Diagram < DVD Section >

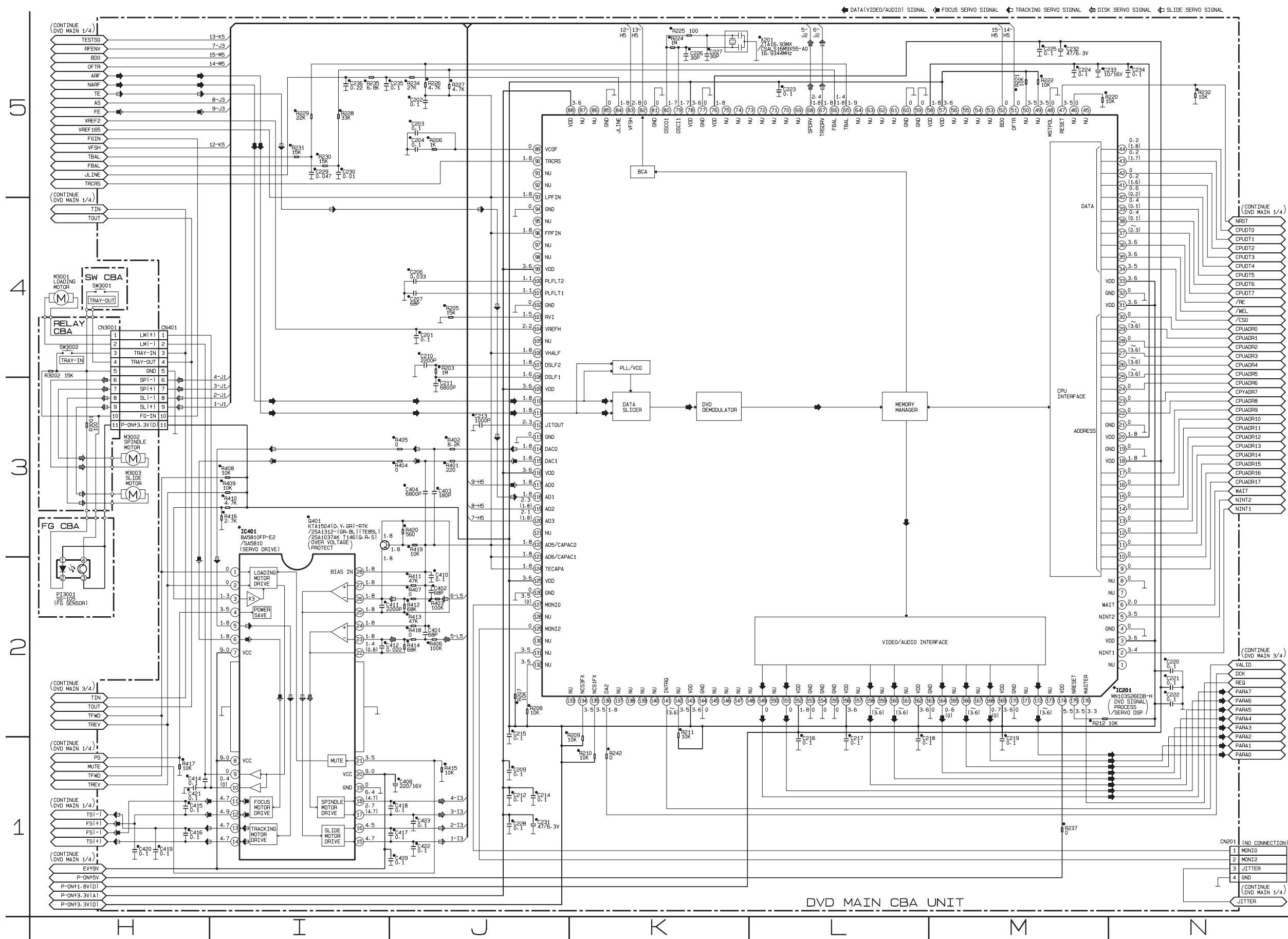
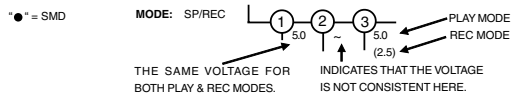

DVD MAIN CBA UNIT

DVD Main 3/4 Schematic Diagram < DVD Section >

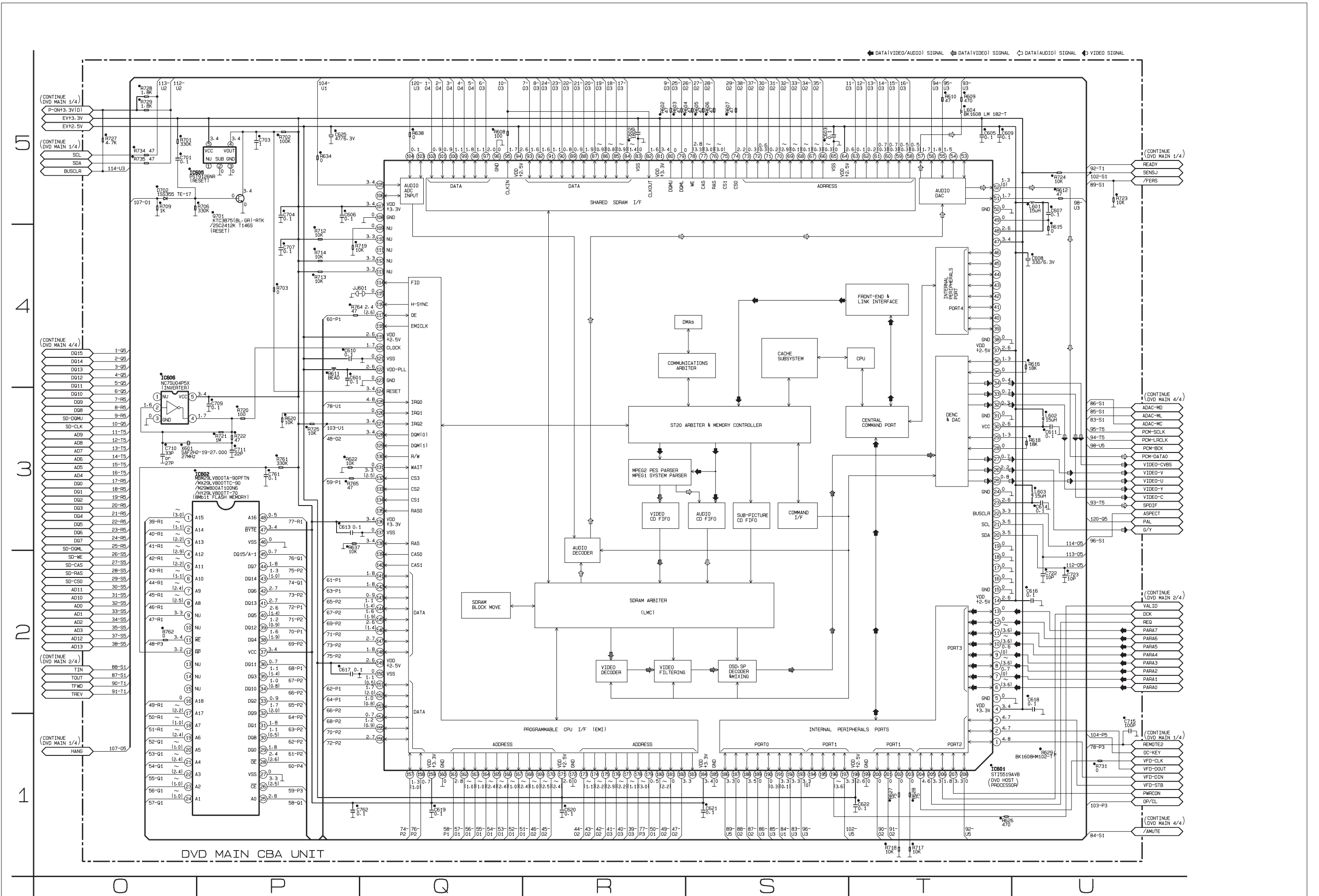
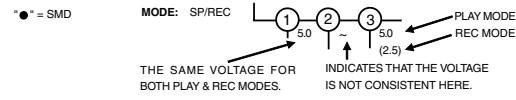

DVD Main 4/4 Schematic Diagram < DVD Section >

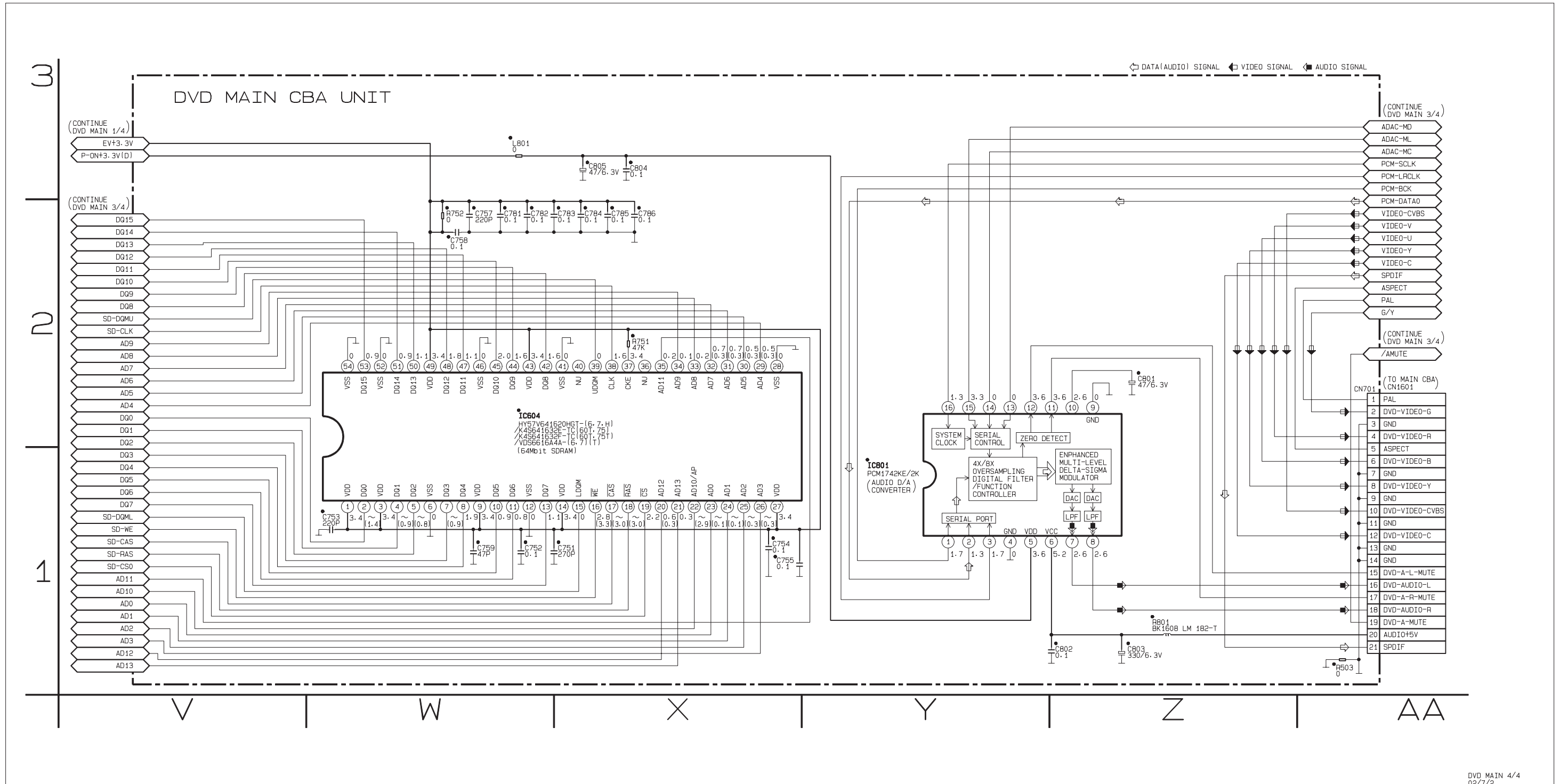
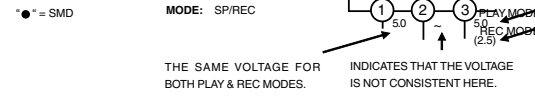

WAVEFORMS

WF1 (TP751 of Main CBA)

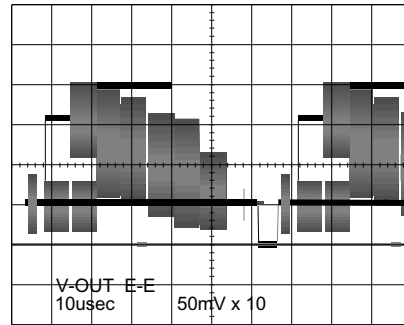

WF1 UPPER (TP751 of Main CBA)

WF2 LOWER (TP302 of Main CBA)

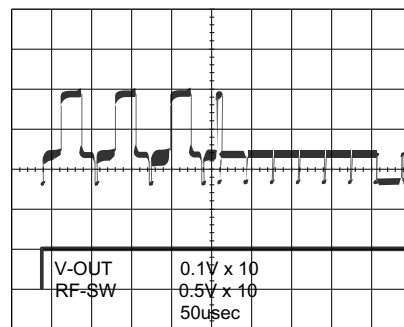

WF5 UPPER (TP301 of Main CBA)

WF2 LOWER (TP302 of Main CBA)

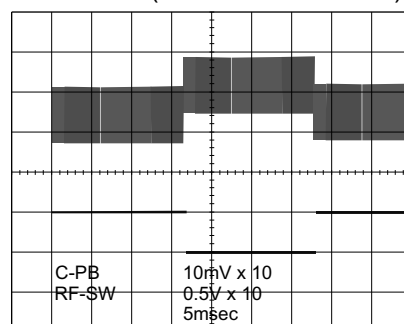

WAVEFORMS

NOTE:

Input

CD: 1kHz PLAY
(WF4~WF6)

DVD: POWER ON (STOP) MODE
(WF1~WF3)

WF1 Pin 5 of CN1601

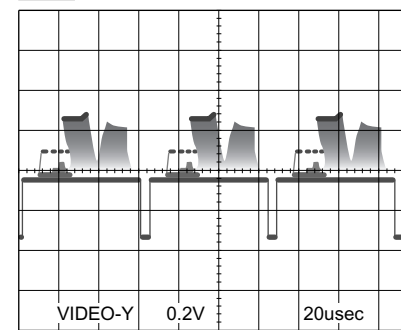

WF4 Pin 13 of CN1601

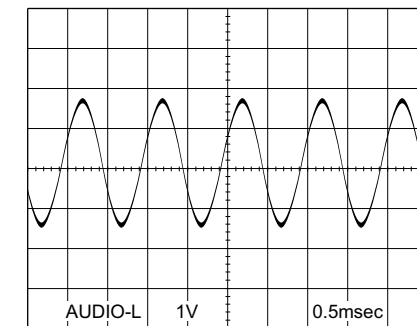

WF2 Pin 7 of CN1601

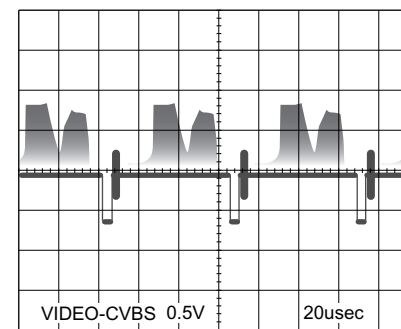

WF5 Pin 15 of CN1601

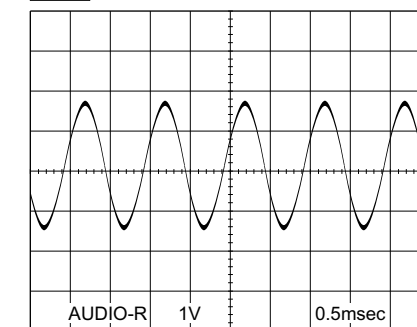

WF3 Pin 9 of CN1601

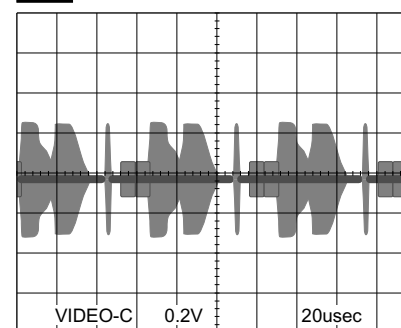

WF6 Pin 18 of CN1601

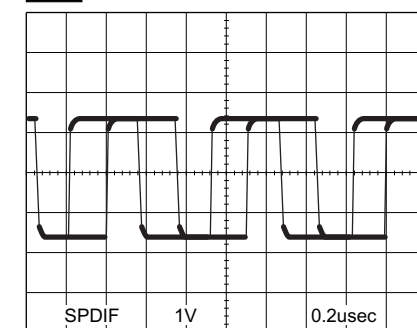

WIRING DIAGRAM < VCR SECTION >

NOTE FOR WIRE CONNECTORS:

1. PREFIX SYMBOL "CN" MEANS CONNECTOR.
(CAN DISCONNECT AND RECONNECT.)
2. PREFIX SYMBOL "CL" MEANS WIRE-SOLDER
HOLES OF THE PCB.
(WIRE IS SOLDERED DIRECTLY.)

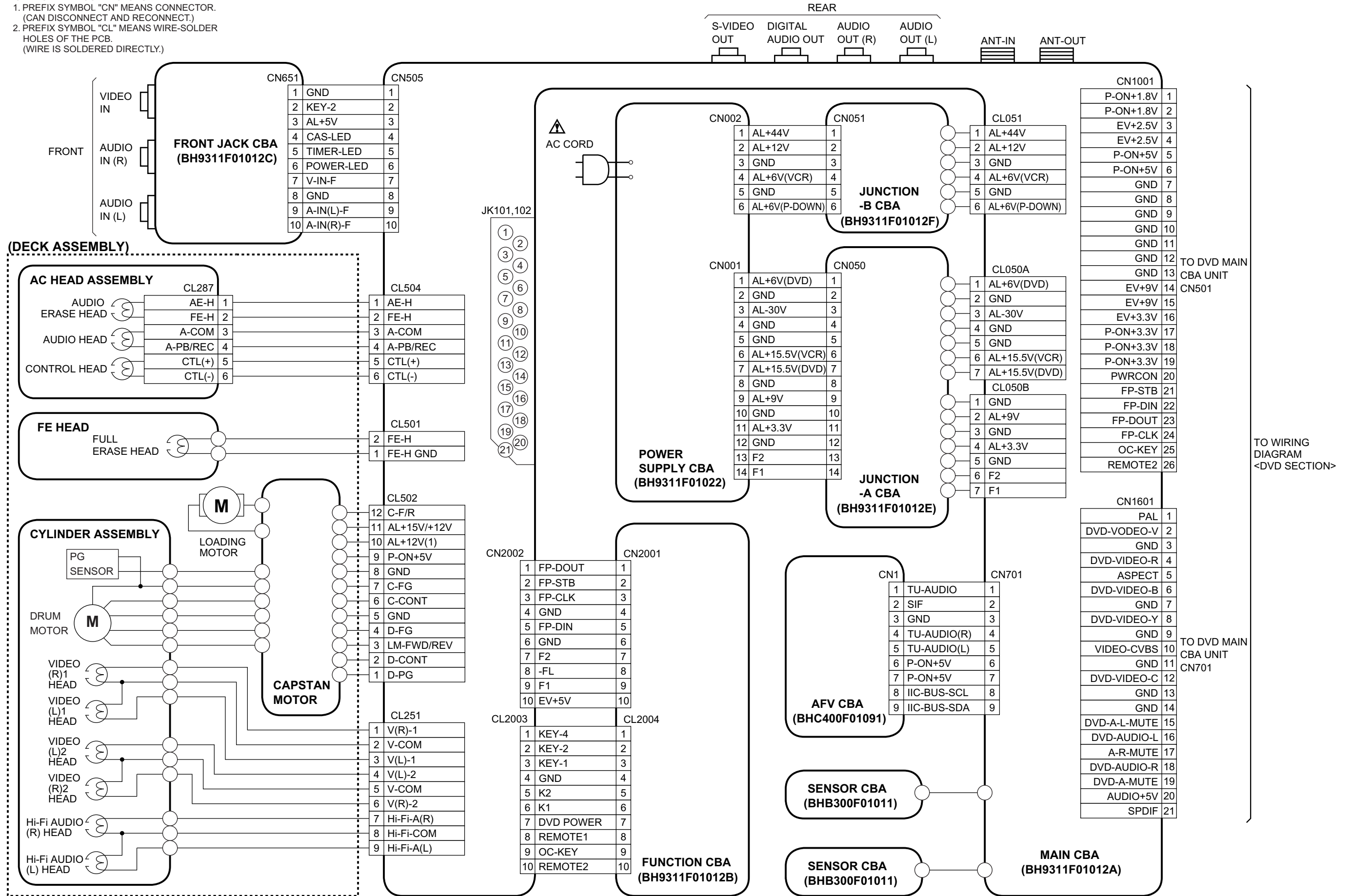

WIRING DIAGRAM< DVD SECTION>

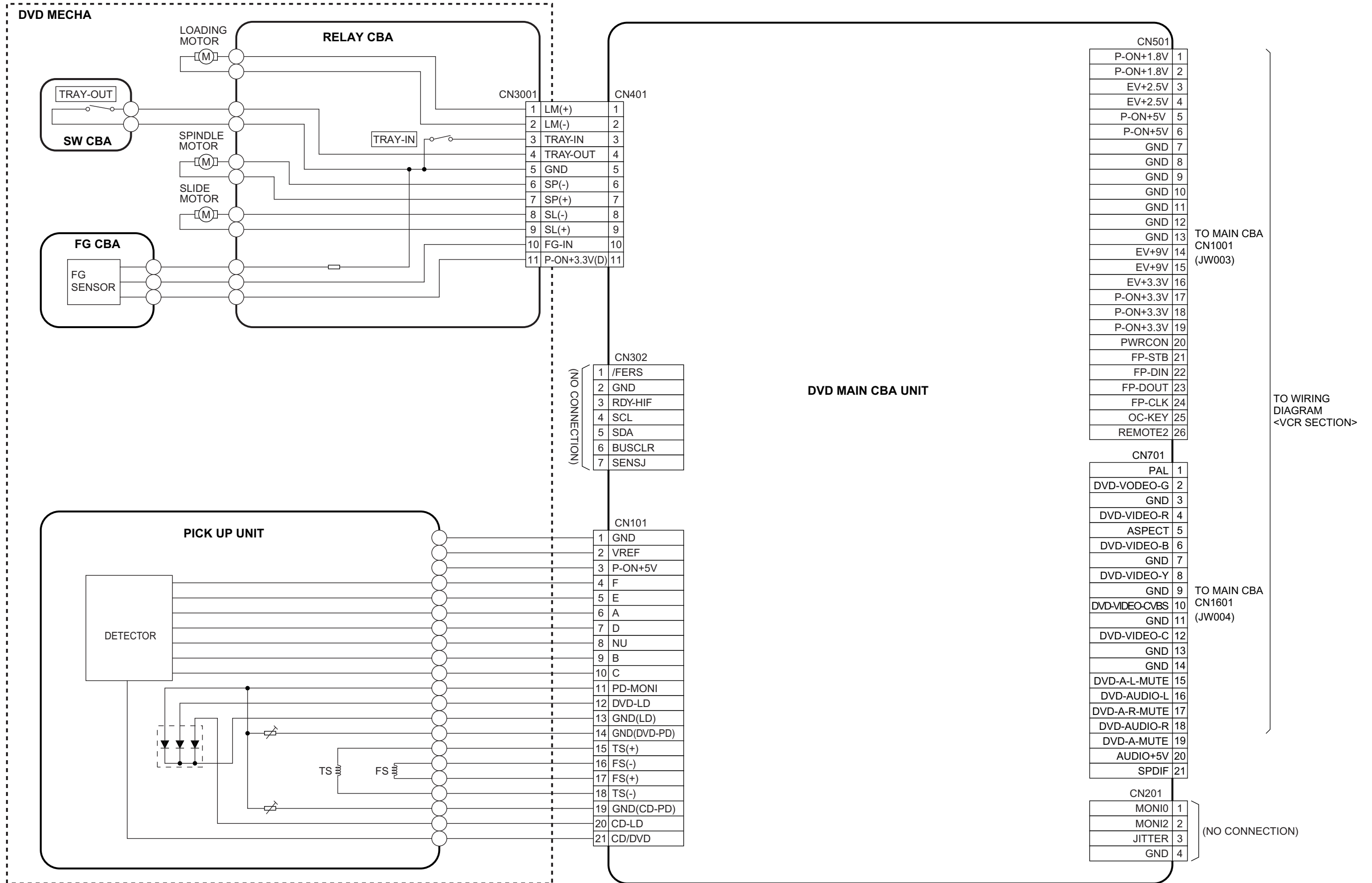

SYSTEM CONTROL TIMING CHARTS

Mode SW : LD-SW

LD-SW Position detection A/D Input voltage Limit (Calculated voltage)	Symbol
3.76V~4.50V (4.12V)	EJ
4.51V~5.00V (5.00V)	CL
0.00V~0.25V (0.00V)	SB
1.06V~1.50V (1.21V)	TL
0.66V~1.05V (0.91V)	FB
1.99V~2.60V (2.17V)	SF
1.51V~1.98V (1.80V)	AU
3.20V~3.75V (3.40V)	AL
0.26V~0.65V (0.44V)	SS
4.51V~5.00V (5.00V)	GC
2.61V~3.19V (2.97V)	RS

Note :

↑ Note:

EJ → RS: Loading FWD (LM-FWD "H", LM-REV "L")

RS → EJ: Loading REV (LM-FWD "L", LM-REV "H")

Stop (A) = Loading

Stop (B) = Unloading

Note :

Symbol	Loading Status
EJ	Eject
CL	Eject ~ REW Reel
SB	REW Reel ~ Stop(B)
TL	Stop(B) ~ Brake Cancel
FB	Brake Cancel
SF	~ Stop(A)
AU	Stop(A) ~ Play / REC
AL	Play / REC ~ Still / Slow
SS	Still / Slow ~ Capstan Reversal
GC	Capstan Reversal ~ RS (REW Search)
RS	RS (REW Search)

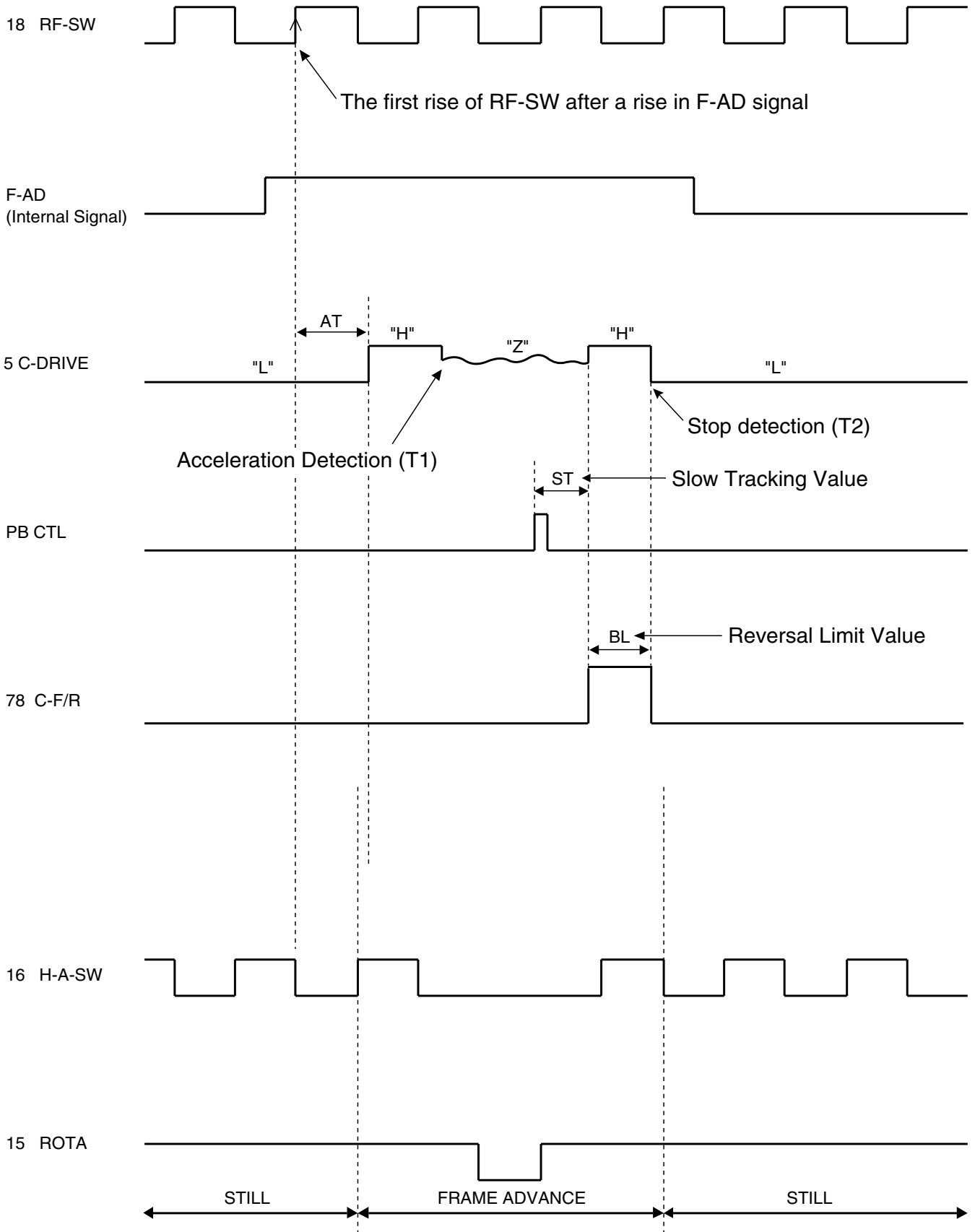

Fig. 1

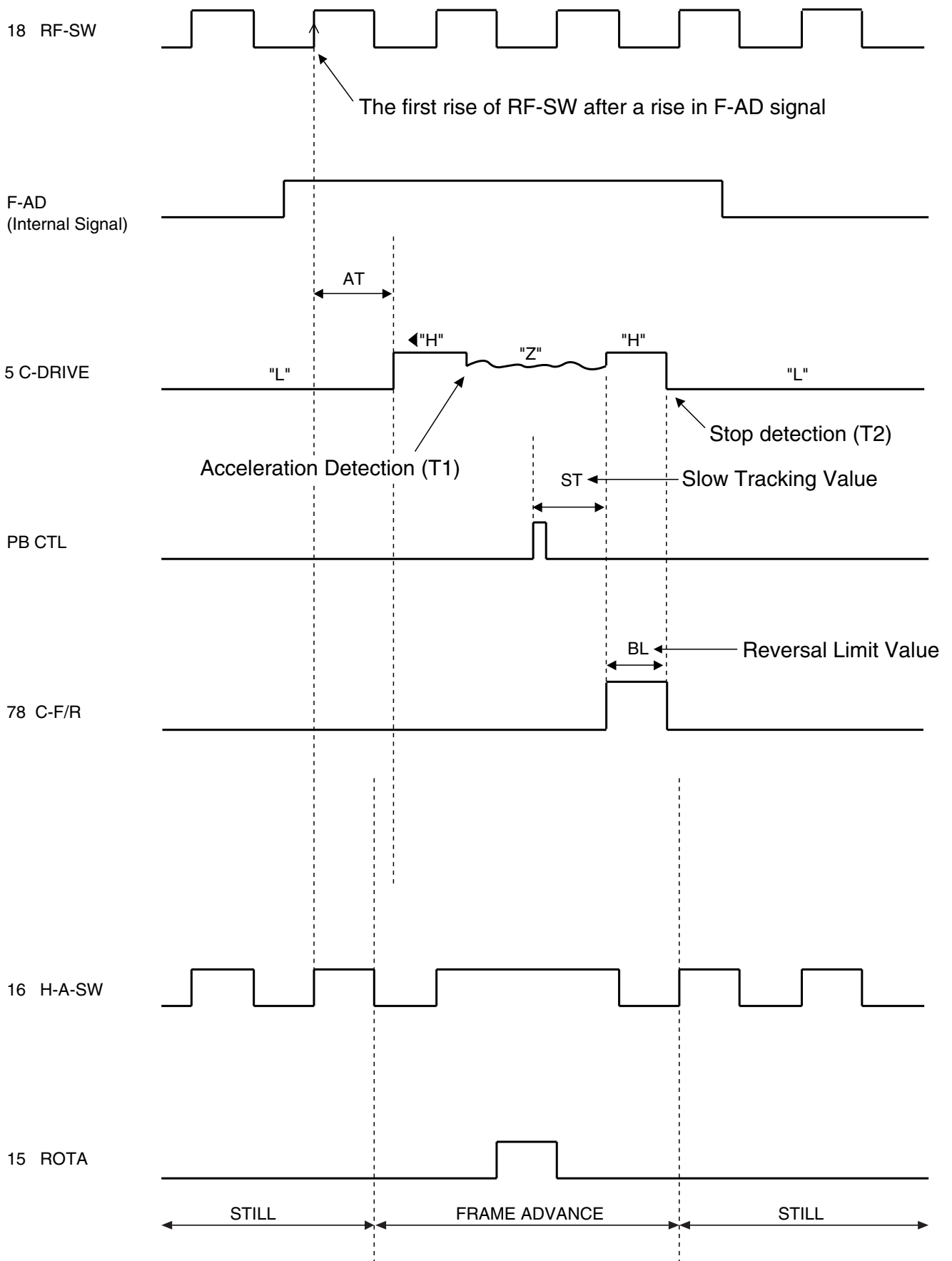

Fig. 2

1. EJECT (POWER OFF) -> CASSETTE IN (POWER ON) -> STOP(B) -> STOP(A) -> PLAY -> RS -> FS -> PLAY -> STILL -> PLAY -> STOP(A)

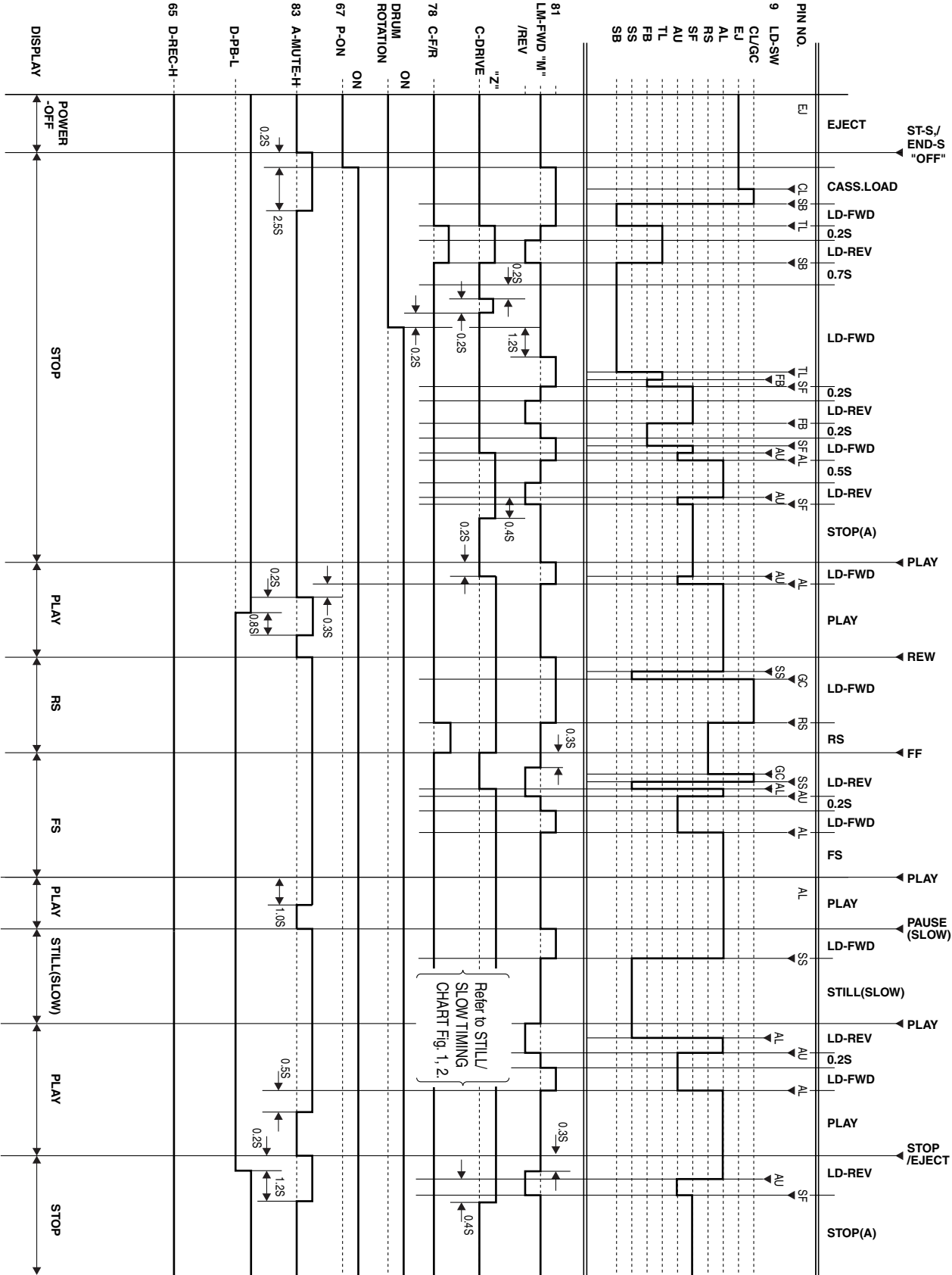

Fig. 3

IC PIN FUNCTION DESCRIPTIONS

[VCR Section]

IC501(SERVO / SYSTEM CONTROL IC)

“H” ≥ 4.5V, “L” ≤ 1.0V

Pin No.	IN/OUT	Signal Name	Function	Active Level
1	IN	SC2-IN	Input Signal from Pin 8 of SCART2	L/Hi-z
2	IN	PG-DELAY	Video Head Switching Pulse Signal Adjusted Voltage	A/D
3	IN	POW-SAF	P-ON Power Detection Input Signal	A/D
4	IN	END-S	Tape End Position Detect Signal	A/D
5	IN	AFC	Automatic Frequency Control Signal	A/D
6	IN	V-ENV	Video Envelope Comparator Signal	A/D
7	IN	KEY-1	Key Scan Input Signal 1	A/D
8	IN	KEY-2	Key Scan Input Signal 2	A/D
9	IN	LD-SW	Deck Mode Position Detector Signal	A/D
10	OUT	ST-S	Tape Start Position Detector Signal	A/D
11	-	N.U.	Not Used	-
12	-	N.U.	Not Used	-
13	OUT	D-V-SYNC	Dummy V-sync Output	H/Hi-z
14	IN	REMOCORN	Remote Control Sensor	L
15	OUT	C-ROTA	Color Phase Rotary Changeover Signal	H/L
16	OUT	H-A-SW	Video Head Amp Switching Pulse	H/L
17	IN	H-A-COMP	Head Amp Comparator Signal	H/L
18	OUT	RF-SW	Video Head Switching Pulse	H/L
19	OUT	Hi-Fi-H-SW	HiFi Audio Head Switching Pulse	H/L
20	IN	DAVN-L	VPS/PDC Data Receive = “L”	L
21	-	N.U.	Not Used	-
22	-	N.U.	Not Used	-

Pin No.	IN/OUT	Signal Name	Function	Active Level
23	OUT	POWER LED	“POWER” LED Signal Output	H/L
24	OUT	CAS LED	“CASSETTE” LED Signal Output	H/L
25	OUT	TIMER LED	“TIMER” LED Signal Output	H/L
26	OUT	REC LED	“REC” LED Signal Output	H/L
27	-	N.U.	Not Used	-
28	OUT	RGB-THROUGH	SCART 2 RGB Through Control Signal	L/Hi-z
29	OUT	DVD LED	“DVD” LED Signal Output	H/L
30	OUT	VCR LED	“VCR” LED Signal Output	H/L
31	IN	REC-SAF-SW	Recoding Safety SW Detect (With Record tab=”L”/ With out Record tab=”H”)	H/L
32	-	N.U.	Not Used	-
33	-	N.U.	Not Used	-
34	IN	RESET	System Reset Signal (Reset=”L”)	L
35	IN	XCIN	Sub Clock	-
36	OUT	XCOUT	Sub Clock	-
37	-	Vcc	Vcc	-
38	IN	XIN	Main Clock Input	-
39	OUT	XOUT	Main Clock Input	-
40	-	Vss	Vss(GND)	-
41	-	N.U.	Not Used	-
42	-	DVD-8PIN-IN	SCART 8Pin DVD Input Control Signal	H/L
43	IN	CLKSEL	Clock Select (GND)	L
44	IN	OSCIN	Clock Input for letter size	-
45	OUT	OSCOU	Clock Output for letter size	-
46	-	NUB	Not Used	-
47	-	PG/LP	PG/LP	-
48	IN	FSC-IN [4.43MHz]	4.43MHz Clock Input	-
49	-	OSDVss	OSDVss	-
50	IN	OSD-V-IN	OSD Video Signal Input	-
51	-	N.U.	Not Used	-

Pin No.	IN/OUT	Signal Name	Function	Active Level
52	OUT	OSD-V-OUT	OSD Video Signal Output	-
53	-	OSDVcc	OSDVcc	-
54	-	HLF	LPF Connected Terminal (Slicer)	-
55	-	N.U.	Not Used	-
56	-	N.U.	Not Used	-
57	-	N.U.	Not Used	-
58	-	N.U.	Not Used	-
59	OUT	8POUT-1	SCART 1 8Pin Output Control Signal	H/L
60	OUT	8POUT-2	SCART 2 8Pin Output Control Signal	H/L
61	IN	A-MODE	Hi-Fi Tape Detection Signal	L
62	-	N.U.	Not Used	-
63	-	N.U.	Not Used	-
64	-	N.U.	Not Used	-
65	OUT	D-REC-H	Delayed Record Signal	L
66	OUT	C-POWER-SW	Capstan Power Switching Pulse	L/Hi-z
67	IN	P-ON-H	Power On Signal at High	H
68	-	N.U.	Not Used	-
69	-	N.U.	Not Used	-
70	-	N.U.	Not Used	-
71	OUT	IIC-BUS-SCL	IIC BUS Control Clock	H/L
72	IN/OUT	IIC-BUS-SDA	IIC BUS Control Data	H/L
73	-	N.U.	Not Used	-
74	OUT	OUTPUT-SELECT	Output Select	H/L
75	-	DVD-POWER-MONITOR	DVD Power Monitor Signal (P-off="H", P-on="L")	H/L
76	OUT	C-CONT	Capstan Motor Control Signal	PWM
77	OUT	D-CONT	Drum Motor Control Signal	PWM
78	OUT	C-F/R	Capstan Motor FWD/REV Control Signal (FWD="L"/REV="H")	H/L
79	IN	S-REEL	Supply Reel Rotation Signal	PULSE
80	IN	T-REEL	Take Up Reel Rotation Signal	PULSE

Pin No.	IN/OUT	Signal Name	Function	Active Level
81	OUT	LM-FWD/REV	Loading Motor Control Signal	H/L/Hi-z
82	OUT	DVD-POWER	DVD Power Control Signal	L
83	OUT	A-MUTE-H	Audio Mute Control Signal (Mute = "H")	H
84	OUT	FF/REW-L	CTL Amp Gain Switching Signal (FF/REW="L")	L
85	-	N.U.	Not Used	-
86	IN	P-DOWN-L	Power Voltage Down Detector Signal	L
87	IN	C-FG	Capstan Motor Rotation Detection Pulse	PULSE
88	-	AMPVss	AMPVss (GND)	-
89	IN	D-FG	Drum Motor Rotation Detection Pulse	PULSE
90	IN	D-PG	Drum Motor Pulse Generator	PULSE
91	-	N.U.	Not Used	-
92	-	AMPVRE _{FIN}	V-Ref for CTL AMP	-
93	-	C	C Terminal	-
94	OUT	CTL (-)	Playback/Record Control Signal (-)	H/L
95	OUT	CTL (+)	Playback/Record Control Signal (+)	H/L
96	-	AMPC	CTL AMP Connected Terminal	-
97	-	CTLAMP out	To Monitor for CTL AMP Output	PULSE
98	-	AMPVcc	AMPVcc	-
99	-	AVcc	A/D Converter Power Input/ Standard Voltage Input	-
100	IN	AGC	IF AGC Control Signal	H/L/Hi-z

Notes:

Abbreviation for Active Level:

PWM -----Pulse Wide Modulation

A/D-----Analog - Digital Converter

IC2001 [PT6315-S(TP)]

Pin No.	In/Out	Signal Name	Name Function
1	In	CLK	Clock Input
2	In	STB	Serial Interface Strobe
3	In	K1	Key Data 1 Input
4	In	K2	Key Data 2 Input
5	-	VSS	GND
6	-	VDD	Power Supply
7	Out	a / KEY-1	Segment Output / Key Souce-1
8	Out	b / KEY-2	Segment Output / Key Souce-2
9	Out	c	Segment Output
10	Out	d / KEY-4	Segment Output/ Key Souce-4
11	Out	e	Segment Output
12	In	f	
13	In	g	
14	Out	h	
15	-	VEE	Pull Down Level
16	Out	i	Segment Output
17	Out	7G	Grid Output
18		6G	
19		5G	
20		4G	
21		3G	
22		2G	
23		1G	
24	-	VDD	Power Supply
25	-	VSS	GND
26	In	OSC	Oscillator Input
27	Out	DOUT	Serial Data Output
28	In	DIN	Serial Data Input

LEAD IDENTIFICATIONS

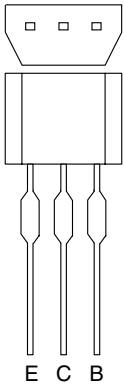

BN1F4M-T
BA1F4M-T
KTA1266(GR)
KTC3199(Y,GR,BL)
2SC2785(J,H,F,K)
KRC103M
KRA103M
BN1L3Z(P)
KRA110M
KTA1273(Y)
KTA1281(Y)
KRA104M
BN1L4M-T
KRC110M-AT
BA1L3Z-T

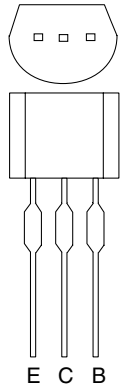

2SC1815-BL(TPE2)
2SC1815-Y(TPE2)
2SC1815-GR(TPE2)
2SC2120-Y(TPE2)
KTC3203(Y)
KTC3205(Y)
2SA966(Y)
2SC2001(K,L)
2SA1020(Y)
2SB892(S)
2SC3266-Y(TPE2)
2SA1015-GR(TPE2)

FS2KM-18A
KIA78R33PI
PQ3RD13(1A)

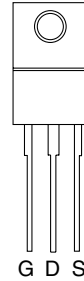

NJM4558D
KIA4558P

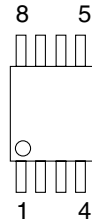

PT6315-S-(TP)

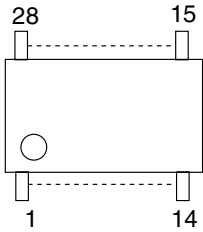

LC74793JM-TRM

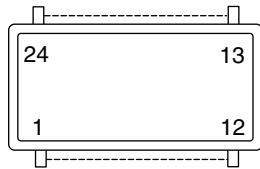

LTV-817(B,C)-F



QSZAD0RMB132
LA71750AM-MTB

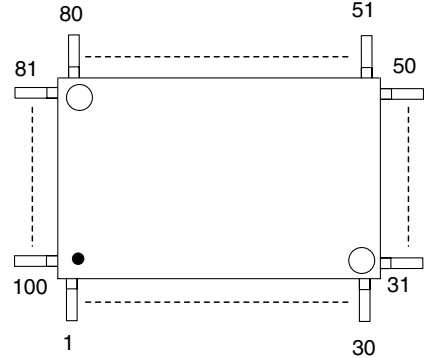

OC-0805T-002
GP1FA512TZV

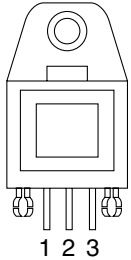

MM1567AJBE

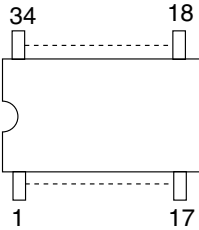

TC4053BF(N)
BU4053BCF-E2

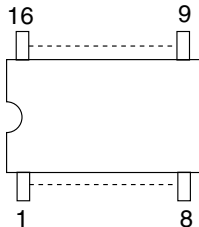

MID-32A22
PT204-6B-12

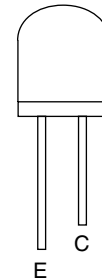

BR24C02F-W
AT24C02N-10SC
M24C02-MN6T
CAT24WC02JI

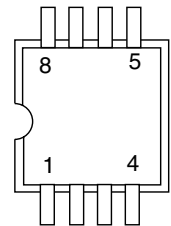

PQ018EF01SZ

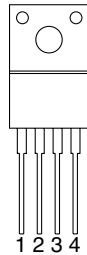

MSP3407G-QG-B8-V3
MSP3407G-QG-B8

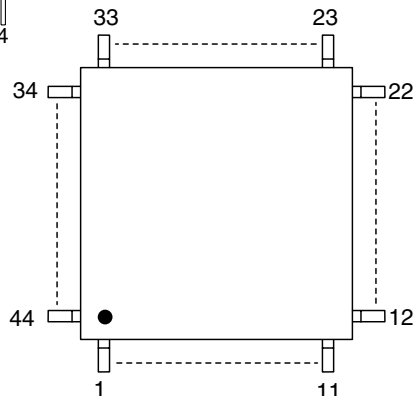

Note:

- A: Anode
- K: Cathode
- E: Emitter
- C: Collector
- B: Base
- R: Reference
- S: Source
- G: Gate
- D: Drain

KIA431-AT

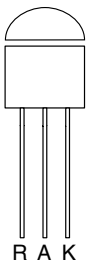

LA72646M-A-MPB

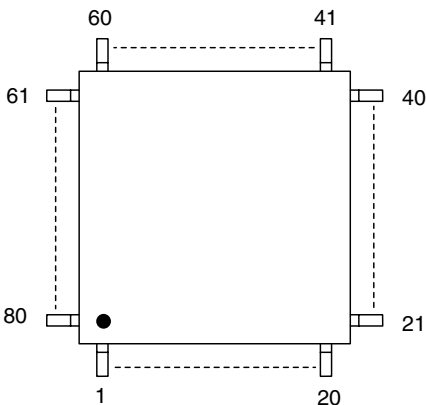

Cabinet

EXPLODED VIEWS

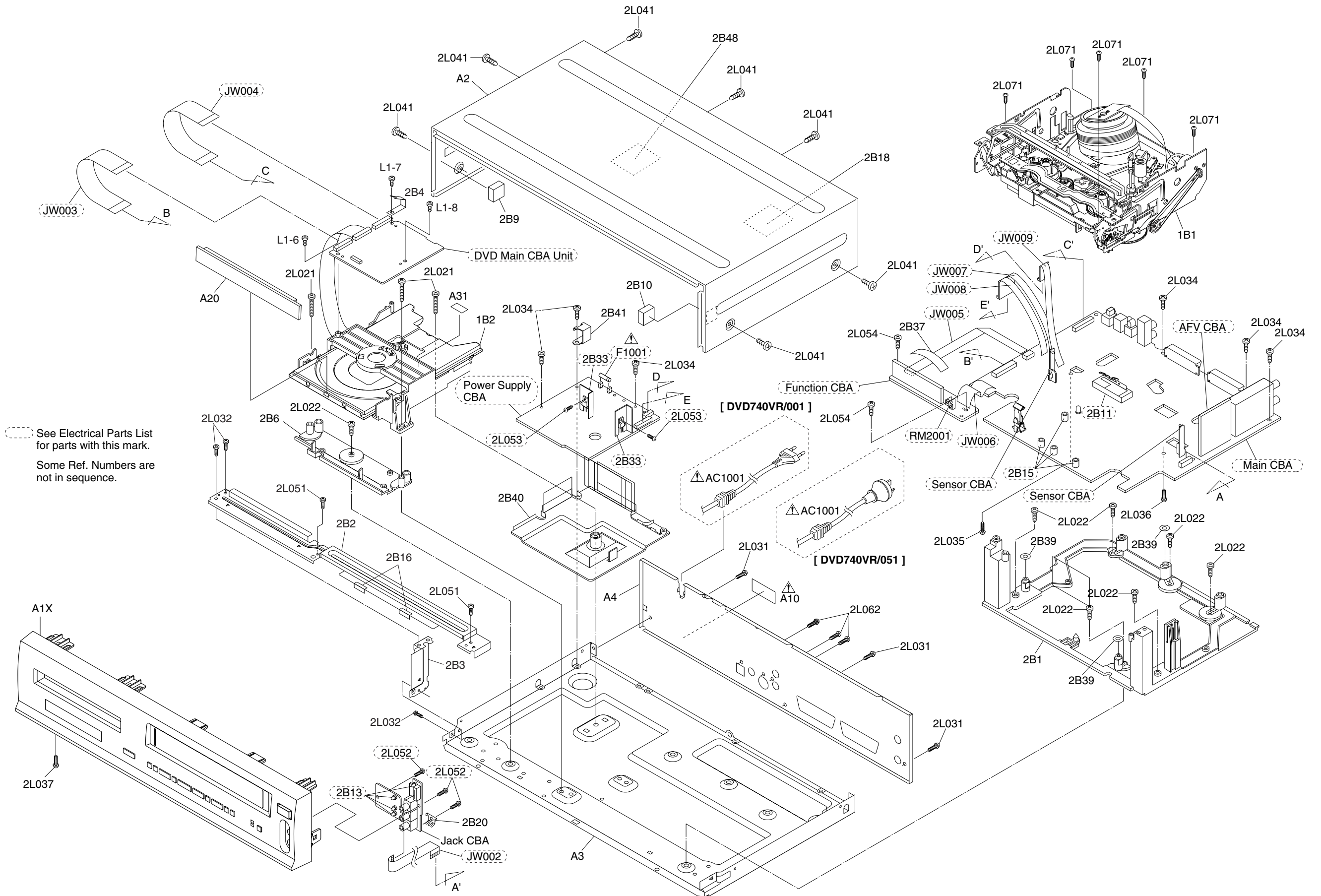

See Electrical Parts List for parts with this mark.
Some Ref. Numbers are not in sequence.

Packing

Some Ref. Numbers are not in sequence.

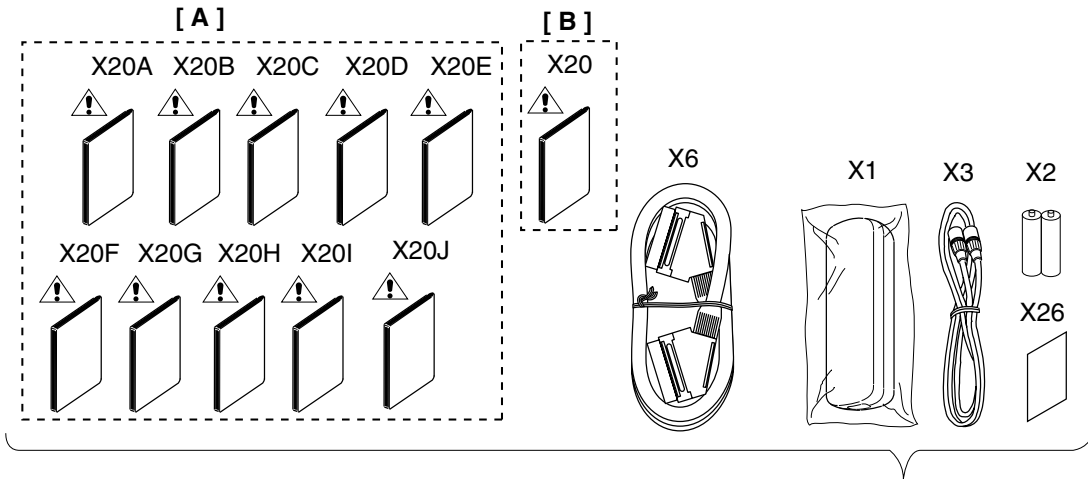

Comparison Chart of Models and Marks

Model	Mark
DVD740VR/001	A
DVD740VR/051	B

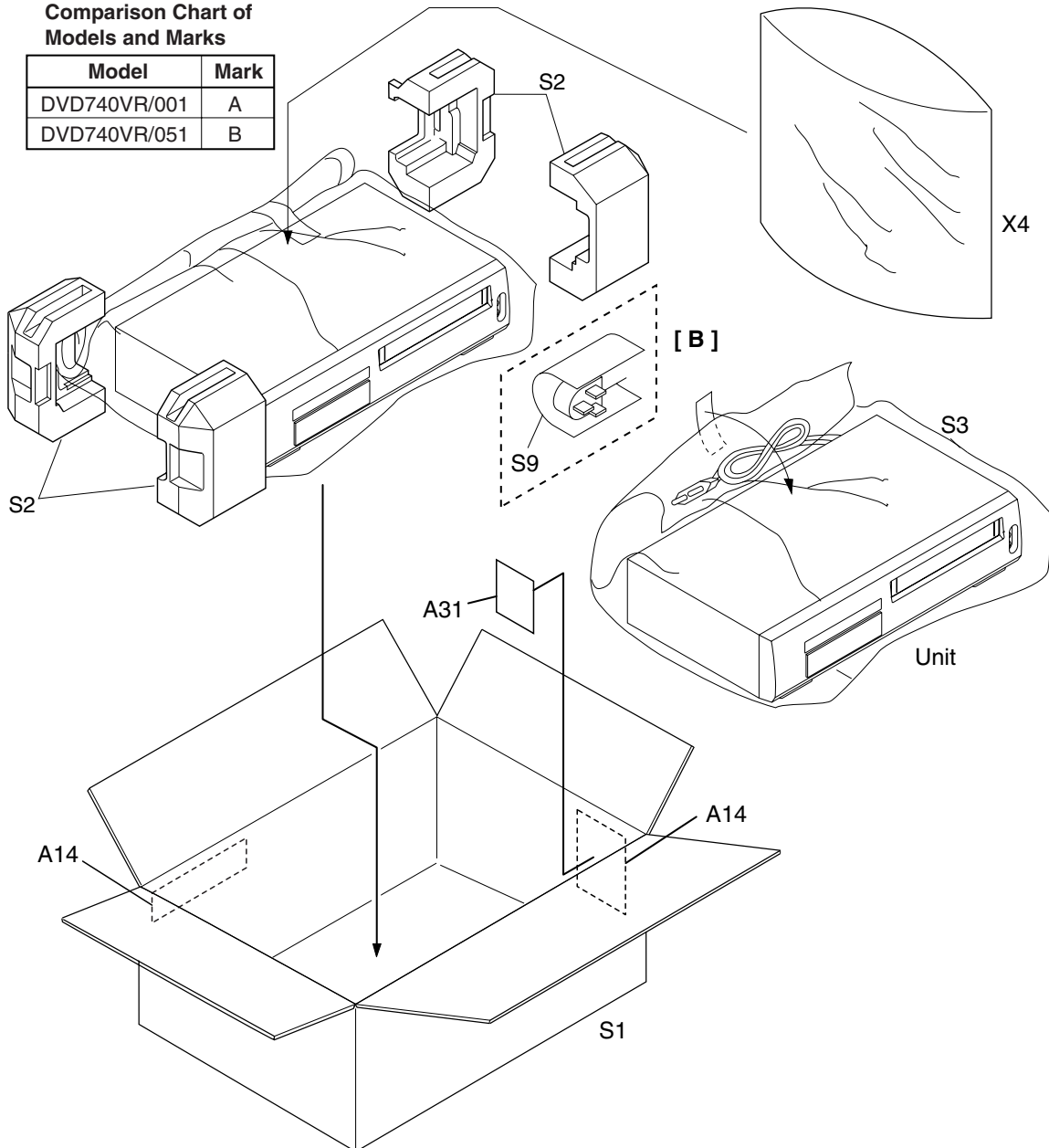

DECK MECHANISM SECTION

DIGITAL VIDEO DISC PLAYER & VIDEO CASSETTE RECORDER

Sec. 2: Deck Mechanism Section

- Standard Maintenance
- Mechanism Alignment Procedures
- Disassembly / Assembly of Mechanism
- Deck Exploded Views
- Deck Parts List

TABLE OF CONTENTS

STANDARD MAINTENANCE	2-1-1
SERVICE FIXTURE AND TOOLS	2-2-1
MECHANICAL ALIGNMENT PROCEDURES	2-3-1
DISASSEMBLY / ASSEMBLY PROCEDURES OF DECK MECHANISM	2-4-1
ALIGNMENT PROCEDURES OF MECHANISM	2-4-9
DECK EXPLODED VIEWS	2-5-1
DECK PARTS LIST	2-6-1

STANDARD MAINTENANCE

Service Schedule of Components

H: Hours ○: Check ●: Change

Deck		Periodic Service Schedule			
Ref.No.	Part Name	1,000 H	2,000 H	3,000 H	4,000 H
B2	Cylinder Assembly	○	●	○	●
B3	Loading Motor Assembly			●	
B8	Pulley Assembly		●		●
B27	Tension Lever Sub Assembly		●		●
B31	AC Head Assembly			●	
B573,B574	Reel S, Reel T			●	
B37	Capstan Motor		●		●
B52	Cap Belt		●		●
*B73	FE Head			●	
B133	Idler Assembly		●		●
B410	Pinch Arm (A) Assembly		●		●
B414	M Brake S Assembly		●		●
B416	M Brake T Assembly		●		●
B525	LDG Belt		●		●

Notes:

- 1.Clean all parts for the tape transport (Upper Drum with Video Head / Pinch Roller / Audio Control Head / Full Erase Head) using 90% Isopropyl Alcohol.
- 2.After cleaning the parts, do all DECK ADJUSTMENTS.
- 3.For the reference numbers listed above, refer to Deck Exploded Views.

* B73 ----- Recording Model only

Cleaning

Cleaning of Video Head

Clean the head with a head cleaning stick or chamois cloth.

Procedure

1. Remove the top cabinet.
2. Put on a glove (thin type) to avoid touching the upper and lower drum with your bare hand.
3. Put a few drops of 90% Isopropyl alcohol on the head cleaning stick or on the chamois cloth and, by slightly pressing it against the head tip, turn the upper drum to the right and to the left.

Notes:

1. The video head surface is made of very hard material, but since it is very thin, avoid cleaning it vertically.
2. Wait for the cleaned part to dry thoroughly before operating the unit.
3. Do not reuse a stained head cleaning stick or a stained chamois cloth.

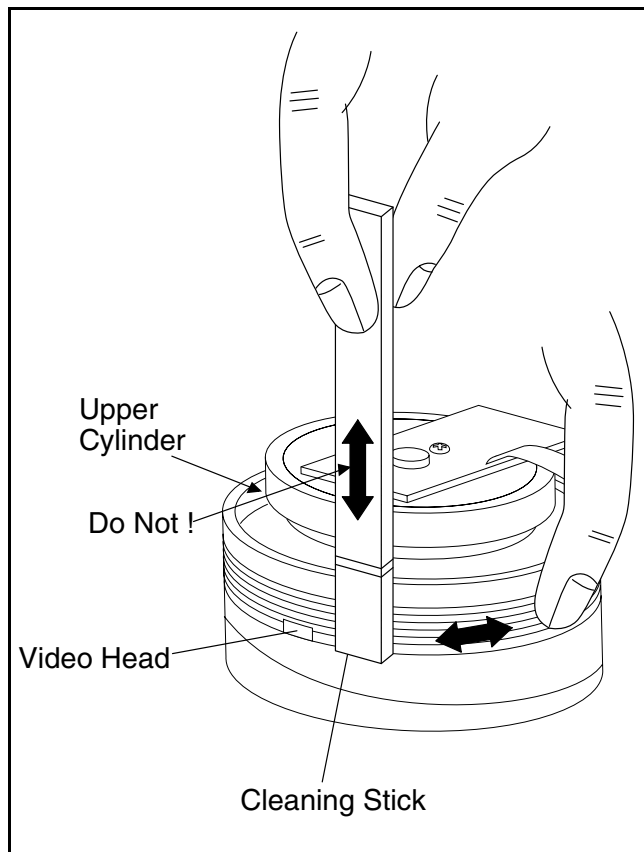

Cleaning of Audio Control Head

Clean the head with a cotton swab.

Procedure

1. Remove the top cabinet.
2. Dip the cotton swab in 90% isopropyl alcohol and clean the audio control head. Be careful not to damage the upper drum and other tape running parts.

Notes:

1. Avoid cleaning the audio control head vertically.
2. Wait for the cleaned part to dry thoroughly before operating the unit or damage may occur.

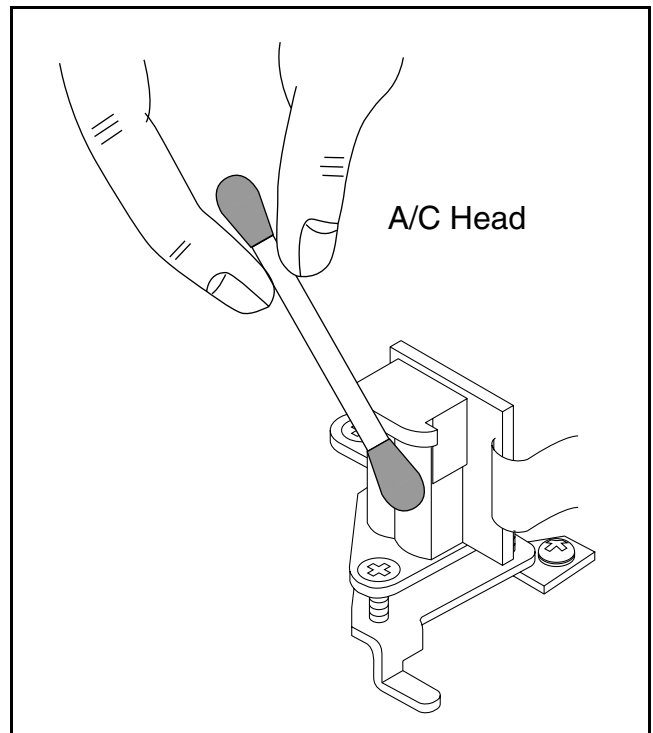

SERVICE FIXTURE AND TOOLS

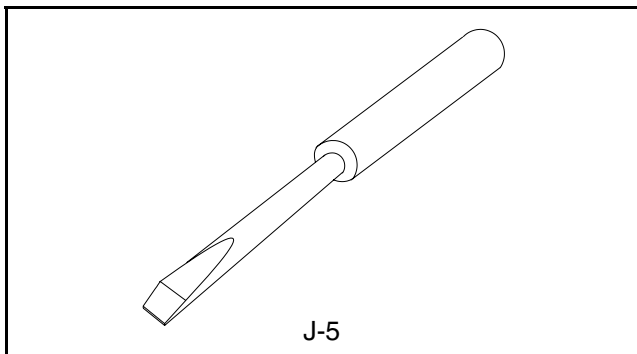
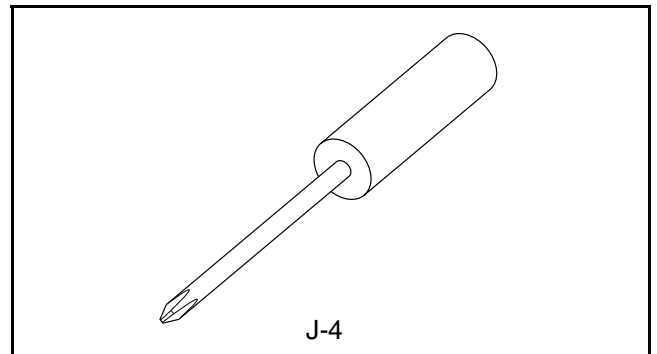
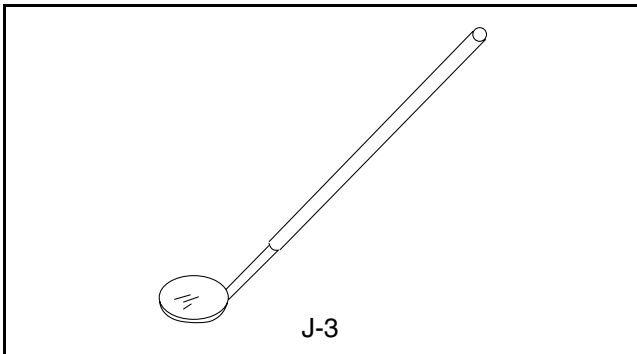
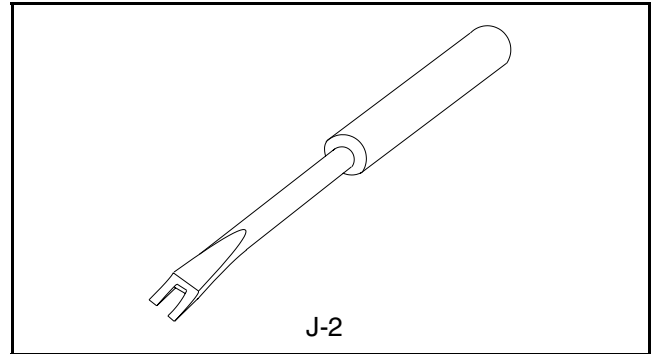
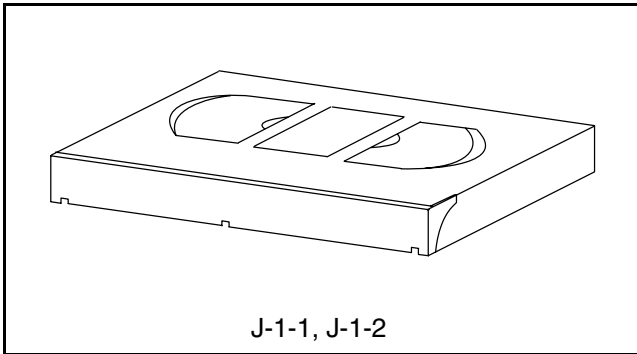

Ref. No.	Name	Part No.	Adjustment
J-1-1	Alignment Tape	FL6A	Electrical Adjustments
J-1-2	Alignment Tape	FL6N8 (2 Head model) FL6NS8 (4 Head model)	Azimuth and X Value Adjustment of Audio Control Head / Adjustment of Envelope Waveform
J-2	Guide Roller Adj.Screwdriver	Available Locally	Guide Roller
J-3	Mirror	Available Locally	Tape Transportation Check
J-4	Azimuth Adj.Screwdriver +	Available Locally	A/C Head Height
J-5	X Value Adj.Screwdriver -	Available Locally	X Value

MECHANICAL ALIGNMENT PROCEDURES

Explanation of alignment for the tape to correctly run starts on the next page. Refer to the information below on this page if a tape gets stuck, for example, in the mechanism due to some electrical trouble of the unit.

Service Information

A. Method for Manual Tape Loading/Unloading

To load a cassette tape manually:

1. Disconnect the AC plug.
2. Remove the Top Case and Front Assembly.
3. Insert a cassette tape. Though the tape will not be automatically loaded, make sure that the cassette tape is all the way in at the inlet of the Cassette Holder. To confirm this, lightly push the cassette tape further in and see if the tape comes back out, by a spring motion, just as much as you have pushed in.
4. Turn the LDG Belt in the appropriate direction shown in Fig. M1 for a minute or two to complete this task.

To unload a cassette tape manually:

1. Disconnect the AC plug.
2. Remove the Top Case and Front Assembly.
3. Make sure that the Moving guide preparations are in the Eject Position.
4. Turn the LDG Belt in the appropriate direction shown in Fig. M1 until the Moving guide preparations come to the Eject Position. Stop turning when the preparations begin clicking or can not be moved further. However, the tape will be left wound around the cylinder.
5. Turn the LDG Belt in the appropriate direction continuously, and the cassette tape will be ejected. Allow a minute or two to complete this task.

B. Method to place the Cassette Holder in the tape-loaded position without a cassette tape

1. Disconnect the AC Plug.
2. Remove the Top Case and Front Assembly.
3. Turn the LDG Belt in the appropriate direction shown in Fig. M1. Release the locking tabs shown in Fig. M1 and continue turning the LDG Belt until the Cassette Holder comes to the tape-loaded position. Allow a minute or two to complete this task.

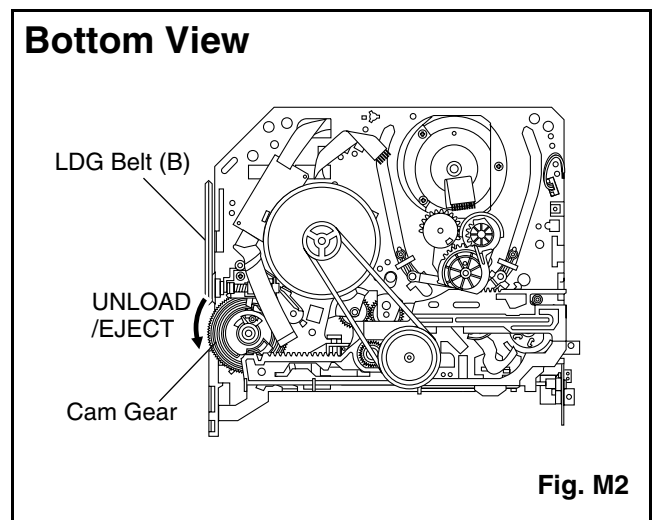
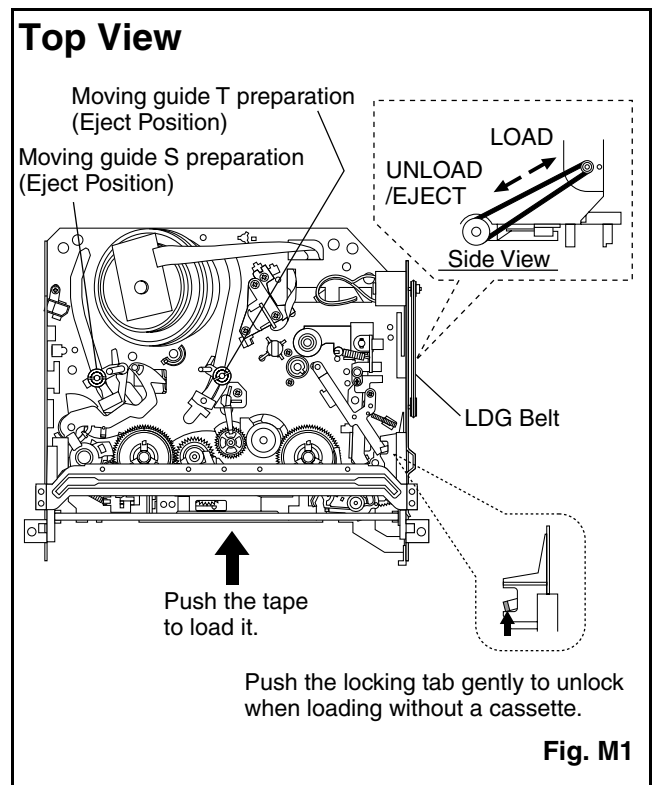

1. Tape Interchangeability Alignment

Note:

To do these alignment procedures, make sure that the Tracking Control Circuit is set to the center position every time a tape is loaded or unloaded. (Refer to page 2-3-4, procedure 1-C, step 2.)

Equipment required:

- Dual Trace Oscilloscope
- VHS Alignment Tape (FL6NS8)
- Guide Roller Adj. Screwdriver
- X-Value Adj. Screwdriver

Note: Before starting this Mechanical Alignment, do all Electrical Adjustment procedures.

Flowchart of Alignment for tape traveling

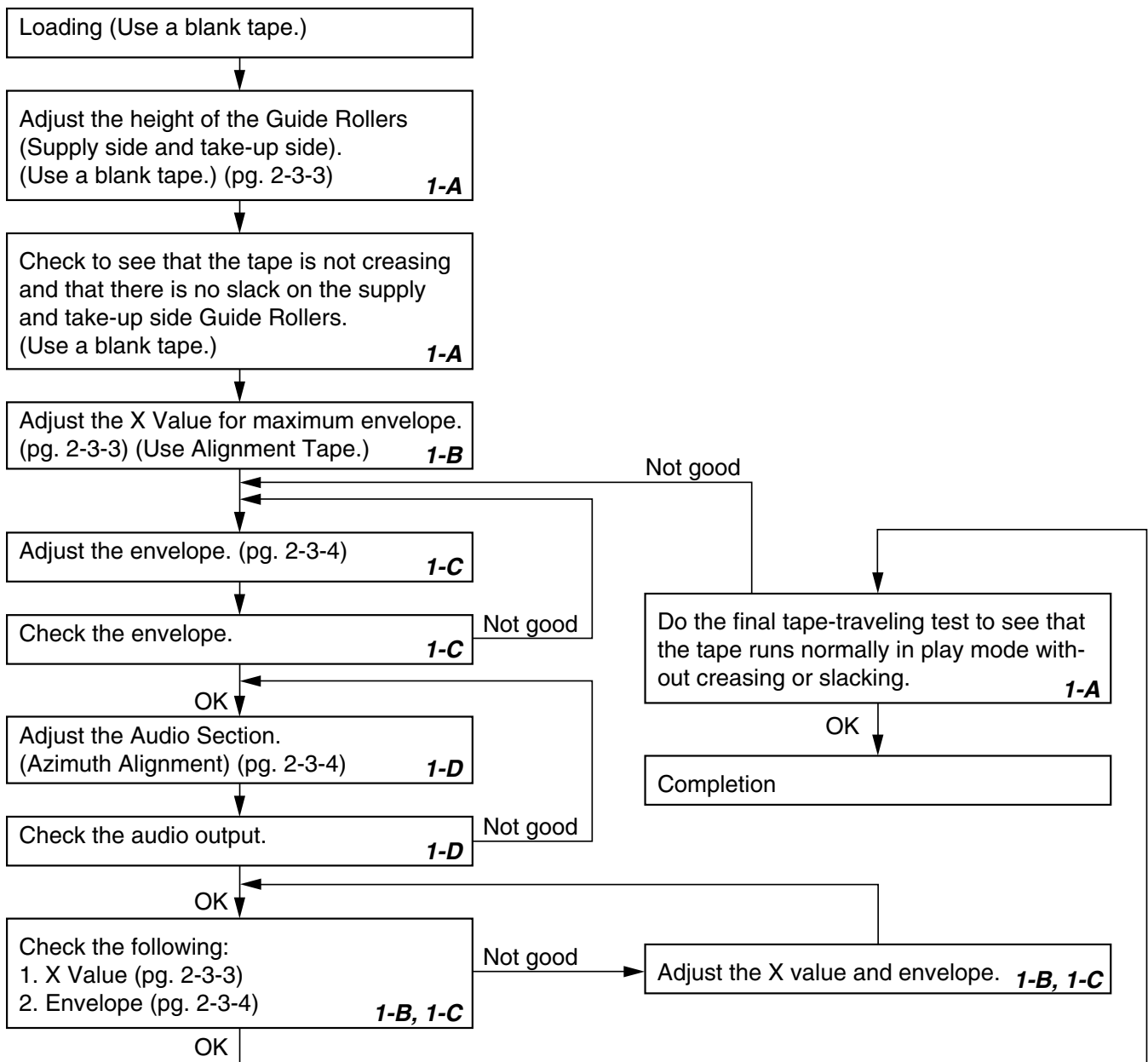

1-A. Preliminary/Final Checking and Alignment of Tape Path

Purpose:

To make sure that the tape path is well stabilized.

Symptom of Misalignment:

If the tape path is unstable, the tape will be damaged.

Note: Do not use an Alignment Tape for this procedure. If the unit is not correctly aligned, the tape may be damaged.

1. Playback a blank cassette tape and check to see that the tape runs without creasing at Guide Rollers [2] and [3], and at points A and B on the lead surface. (Refer to Fig M3 and M4.)
2. If creasing is apparent, align the height of the guide rollers by turning the top of Guide Rollers [2] and [3] with a Guide Roller Adj. Screwdriver. (Refer to Fig. M3 and M5.)

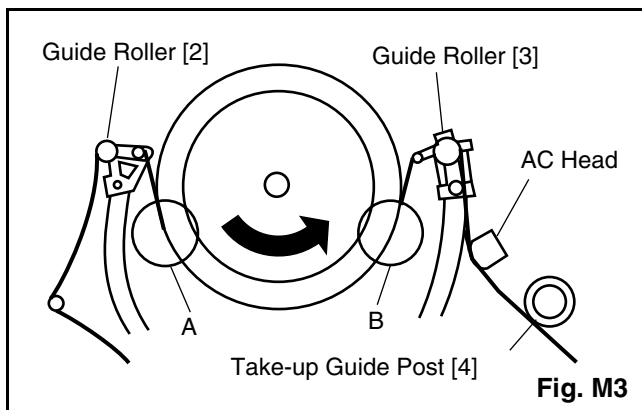

Fig. M3

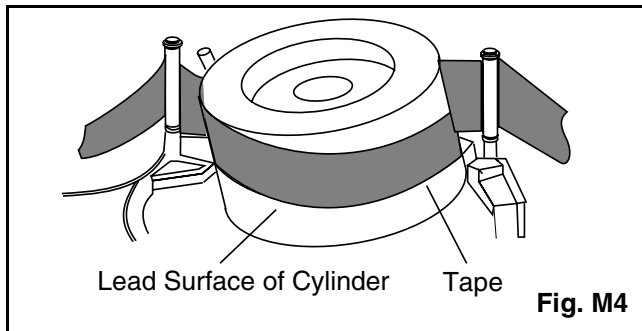

Fig. M4

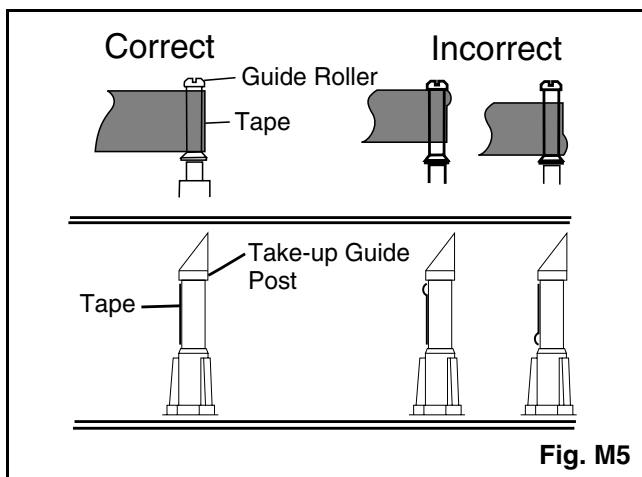

Fig. M5

3. Check to see that the tape runs without creasing at Take-up Guide Post [4] or without snaking between Guide Roller [3] and AC Head. (Fig. M3 and M5)
4. If creasing or snaking is apparent, adjust the Tilt Adj. Screw of the AC Head. (Fig. M6)

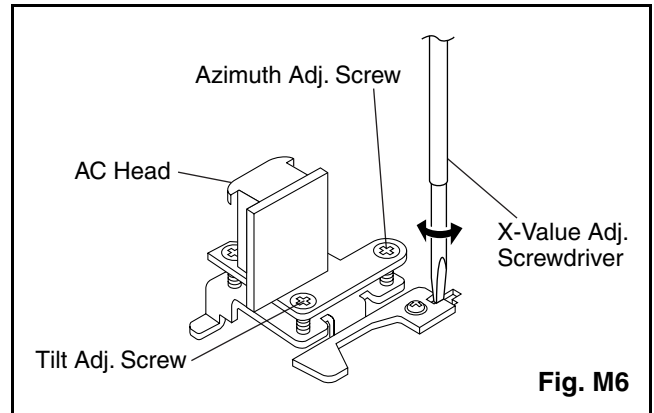

Fig. M6

1-B. X Value Alignment

Purpose:

To align the Horizontal Position of the Audio/Control/Erase Head.

Symptom of Misalignment:

If the Horizontal Position of the Audio/Control/Erase Head is not properly aligned, maximum envelope cannot be obtained at the Neutral position of the Tracking Control Circuit.

1. Connect the oscilloscope to TP301 (C-PB) and TP501 (CTL) on the Main CBA. Use TP502 (RF-SW) as a trigger.
2. Playback the Gray Scale of the Alignment Tape (FL6NS8) and confirm that the PB FM signal is present.
3. Set the Tracking Control Circuit to the center position by pressing CH UP button then "PLAY" button on the unit. (Refer to note on bottom of page 2-3-4.)
4. Use the X-Value Adj. Screwdriver so that the PB FM signal at TP301 (C-PB) is maximum. (Fig. M6)
5. Press CH UP button on the unit until the CTL waveform has shifted by approx. +2msec. Make sure that the envelope is simply attenuated (shrinks in height) during this process so that you will know the envelope has been at its peak.

6. Press CH DOWN button on the unit until the CTL waveform has shifted from its original position (not the position achieved in step 5, but the position of CTL waveform in step 4) by approximately -2msec. Make sure that the envelope is simply attenuated (shrinks in height) once CTL waveform passes its original position and is further brought in the minus direction.
7. Set the Tracking Control Circuit to the center position by pressing CH UP button and then "PLAY" button.

1-C. Checking/Adjustment of Envelope Waveform

Purpose:

To achieve a satisfactory picture and precise tracking.

Symptom of Misalignment:

If the envelope output is poor, noise will appear in the picture. The tracking will then lose precision and the playback picture will be distorted by any slight variation of the Tracking Control Circuit.

1. Connect the oscilloscope to TP301 (C-PB) on the Main CBA. Use TP502 (RF-SW) as a trigger.
2. Playback the Gray Scale on the Alignment Tape (FL6NS8). Set the Tracking Control Circuit to the center position by pressing CH UP button and then "PLAY" button on the unit. Adjust the height of Guide Rollers [2] and [3] (Fig. M3, Page 2-3-3) watching the oscilloscope display so that the envelope becomes as flat as possible. To do this adjustment, turn the top of the Guide Roller with the Guide Roller Adj. Screwdriver.
3. If the envelope is as shown in Fig. M7, adjust the height of Guide Roller [2] (Refer to Fig. M3) so that the waveform looks like the one shown in Fig. M9.
4. If the envelope is as shown in Fig. M8, adjust the height of Guide Roller [3] (Refer to Fig. M3) so that the waveform looks like the one shown in Fig. M9.
5. When Guide Rollers [2] and [3] (Refer to Fig.M3) are aligned properly, there is no envelope drop either at the beginning or end of track as shown in Fig. M9.

Note: Upon completion of the adjustment of Guide Rollers [2] and [3] (Refer to Fig. M3), check the X Value by pushing the CH UP or DOWN buttons alternately, to check the symmetry of the envelope. Check the number of pushes to ensure center position. The number of pushes CH UP button to achieve 1/2 level of envelope should match the number of pushes CH DOWN button from center. If required, redo the "X Value Alignment."

1-D. Azimuth Alignment of Audio/Control/Erase Head

Purpose:

To correct the Azimuth alignment so that the Audio/Control/Erase Head meets tape tracks properly.

Symptom of Misalignment:

If the position of the Audio/Control/Erase Head is not properly aligned, the Audio S/N Ratio or Frequency Response will be poor.

1. Connect the oscilloscope to the audio output jack on the rear side of the deck.
2. Playback the alignment tape (FL6NS8) and confirm that the audio signal output level is 6kHz.
3. Adjust Azimuth Adj. Screw so that the output level on the AC Voltmeter or the waveform on the oscilloscope is at maximum. (Fig. M6)

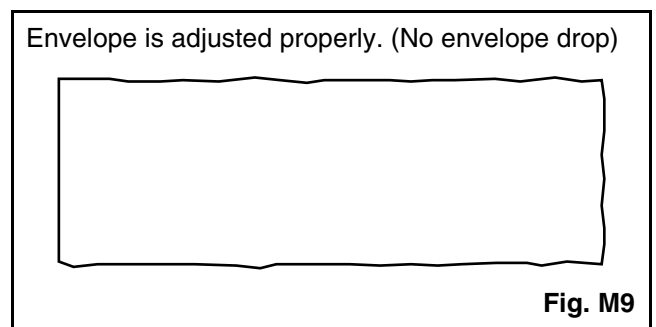
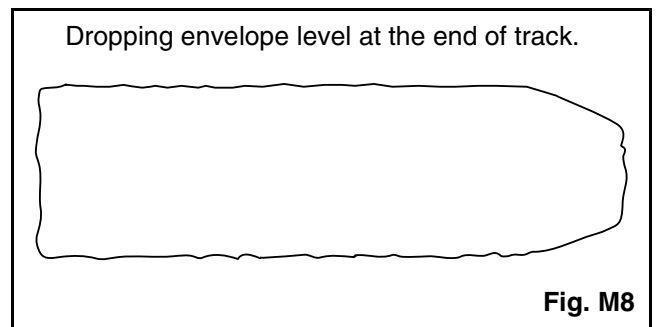
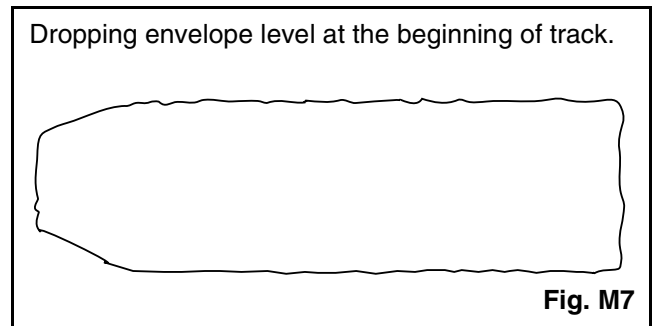

DISASSEMBLY/ASSEMBLY PROCEDURES OF DECK MECHANISM

Before following the procedures described below, be sure to remove the deck assembly from the cabinet. (Refer to CABINET DISASSEMBLY INSTRUCTIONS on page 1-7-1.)

All the following procedures, including those for adjustment and replacement of parts, should be done in Eject mode; see the positions of [45] and [46] in Fig.DM1 on page 2-4-3. When reassembling, follow the steps in reverse order.

STEP /LOC. No.	START-ING No.	PART		REMOVAL		INSTALLATION
				Fig. No.	REMOVE/*UNHOOK/ UNLOCK/RELEASE/ UNPLUG/DESOLDER	ADJUSTMENT CONDITION
[1]	[1]	Guide Holder A	T	DM3	2(S-1)	
[2]	[1]	Cassette Holder Assembly	T	DM4		
[3]	[2]	Slider L	T	DM5	(S-2)	
[4]	[2]	Slider R	T	DM5	(S-3)	
[5]	[4]	Lock Lever	T	DM5	(S-4),*(P-1)	
[6]	[2]	C Plate	T	DM5		
[7]	[7]	Cylinder Assembly	T	DM1,DM6	Desolder, 3(S-5)	
[8]	[8]	Loading Motor Assembly	T	DM1,DM7	Desolder, LDG Belt, 2(S-6)	
[9]	[9]	AC Head Assembly	T	DM1,DM7	(S-7)	
[10]	[2]	Tape Guide Assembly	T	DM1,DM8	*(P-2)	
[11]	[10]	Door Opener B	T	DM1,DM8	*(L-1),*(L-2)	
[12]	[11]	Pinch Arm (B)	T	DM1,DM8	*(P-3)	
[13]	[12]	Pinch Arm (A) Assembly	T	DM1,DM8		
[14]	[14]	FE Head	T	DM1,DM9	(S-9)	
[15]	[15]	Prism	T	DM1,DM9	(S-10)	
[16]	[2]	Slider Shaft	T	DM10	(S-11),*(L-3)	
[17]	[16]	C Drive Lever L	T	DM10		
[18]	[16]	C Drive Lever R	T	DM10		
[19]	[7],[10]	Capstan Motor	B	DM2,DM11	3(S-12), Cap Belt	
[20]	[20]	Clutch Assembly(HI)	B	DM2,DM12	(C-1)	
[21]	[20]	Center Gear	B	DM12		
[22]	[22]	Cam Holder F	B	DM2,DM13	(C-2)	
[23]	[22]	Cam Gear (B)	B	DM2,DM13	(C-3),*(P-4)	
[24]	[24]	Mode Gear	B	DM2,DM14	(C-4)	
[25]	[20],[23], [24]	Mode Lever(HI)	B	DM2,DM14	(C-5), *(L-4)	
[26]	[22]	Worm Holder	B	DM2,DM14	(S-15)	
[27]	[26]	Pulley Assembly	B	DM2,DM14		
[28]	[22],[25]	Cam Gear (A)	B	DM2,DM14		(+)Refer to Alignment Sec.Pg.2-4-10
[29]	[20]	TR Gear C	B	DM2,DM14	(C-6)	
[30]	[29]	TR Gear Spring	B	DM14		
[31]	[30]	TR Gear A/B	B	DM1,DM14		
[32]	[31]	FF Arm(HI)	B	DM1,DM14		
[33]	[21],[25]	Idler Assembly(HI)	B	DM1,DM15	*(L-5)	
[34]	[25]	BT Arm	B	DM2,DM15	*(P-5)	

STEP /LOC. No.	START-ING No.	PART		REMOVAL		INSTALLATION
				Fig. No.	REMOVE/*UNHOOK/ UNLOCK/RELEASE/ UNPLUG/DESOLDER	ADJUSTMENT CONDITION
[35]	[25]	Loading Arm S(B) Assembly	B	DM2,DM15		(+)Refer to Alignment Sec.Pg.2-4-9
[36]	[35]	Loading Arm T(B) Assembly	B	DM2,DM15		(+)Refer to Alignment Sec.Pg.2-4-9
[37]	[2],[25]	M Brake T(HI) Assembly	T	DM1,DM16	*(P-6)	
[38]	[2],[25]	M Brake S(HI) Assembly	T	DM1,DM16	*(P-7)	
[39]	[38]	Tension Lever Sub Assembly	T	DM1,DM16		
[40]	[39]	T Lever Holder	T	DM1,DM16	*(L-6)	
[41]	[2]	M Gear(HYT)	T	DM1,DM16	(C-7)	
[42]	[2],[15]	Sensor Gear	T	DM1,DM16	(C-8)	
[43]	[37],[41]	Reel T	T	DM1,DM16		
[44]	[39]	Reel S	T	DM1,DM16		
[45]	[35],[38]	Moving Guide S Preparation	T	DM1,DM17		
[46]	[36]	Moving Guide T Preparation	T	DM1,DM17		
[47]	[19]	TG Post Assembly	T	DM1,DM17	*(L-7)	
[48]	[18],[28]	Rack Assembly	R	DM18		(+)Refer to Alignment Sec.Pg.2-4-10
[49]	[48]	F Door Opener	R	DM18		
[50]	[46]	Cleaner Lever Assembly	T	DM1,DM6	*(L-8)	
↓ (1)	↓ (2)	↓ (3)	↓ (4)	↓ (5)	↓ (6)	↓ (7)

(1): Follow steps in sequence. When reassembling, follow the steps in reverse order.

These numbers are also used as identification (location) No. of parts in the figures.

(2): Indicates the part to start disassembling with in order to disassemble the part in column (1).

(3): Name of the part

(4): Location of the part: T=Top B=Bottom R=Right L=Left

(5): Figure Number

(6): Identification of parts to be removed, unhooked, unlocked, released, unplugged, unclamped, or desoldered.

P=Spring, W=Washer, C=Cut Washer, S=Screw, *=Unhook, Unlock, Release, Unplug, or Desolder

e.g., 2(L-2) = two Locking Tabs (L-2).

(7): Adjustment Information for Installation

(+):Refer to Deck Exploded Views for lubrication.

Top View

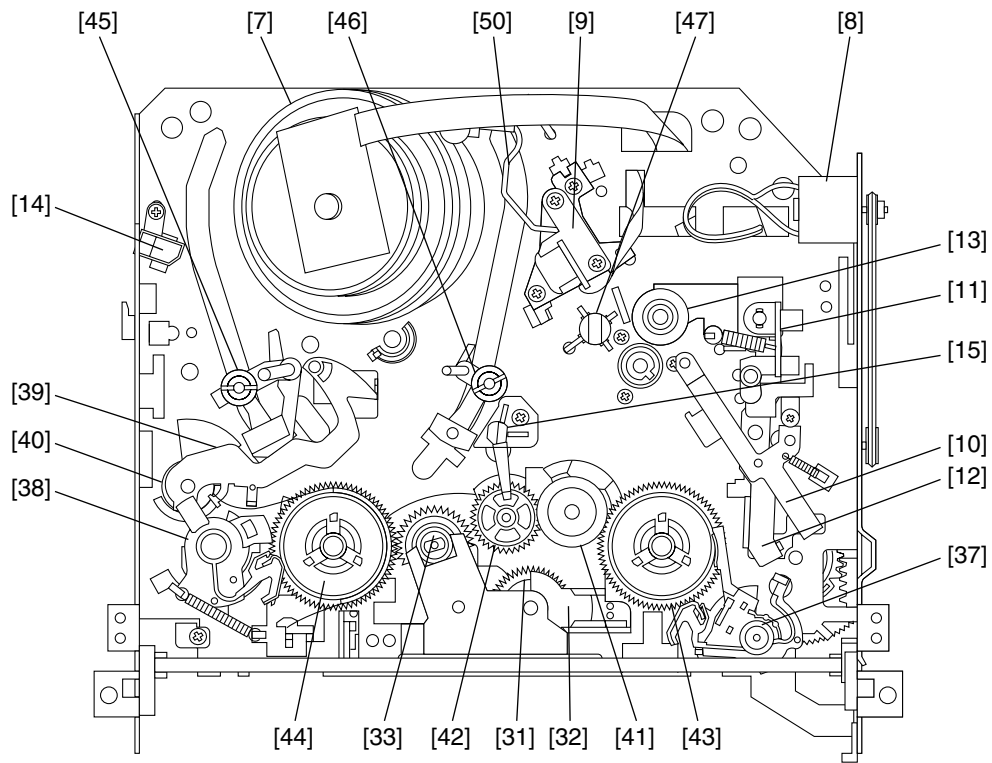

Fig. DM1

Bottom View

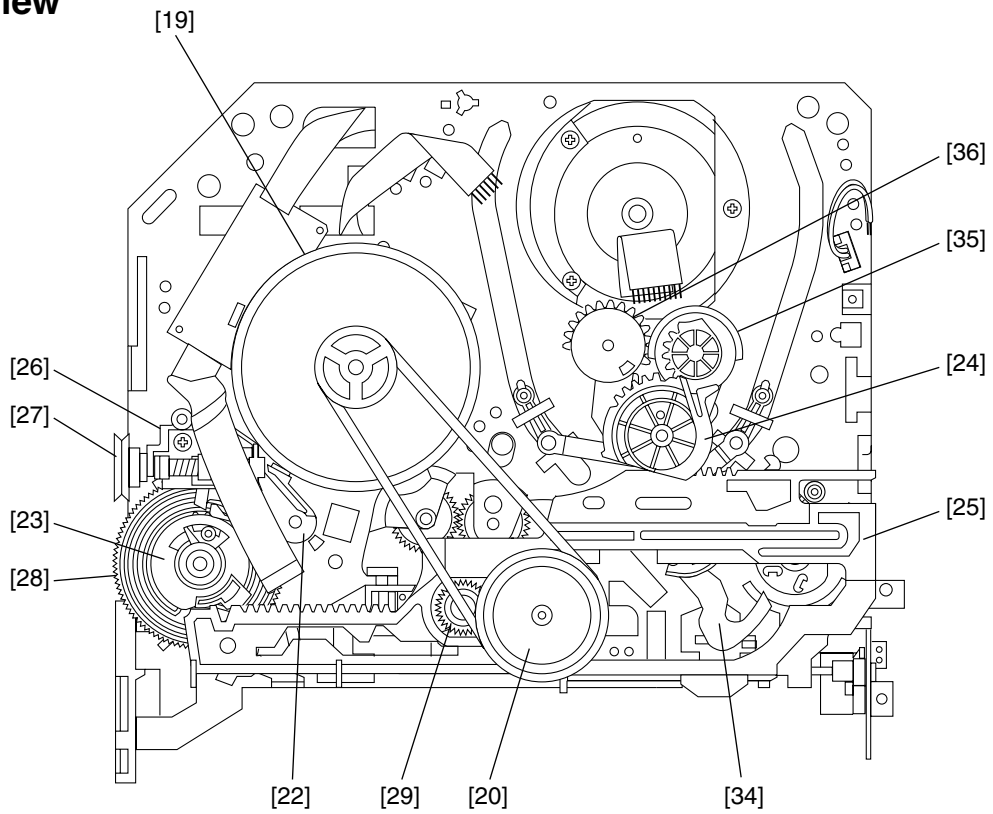

Fig. DM2

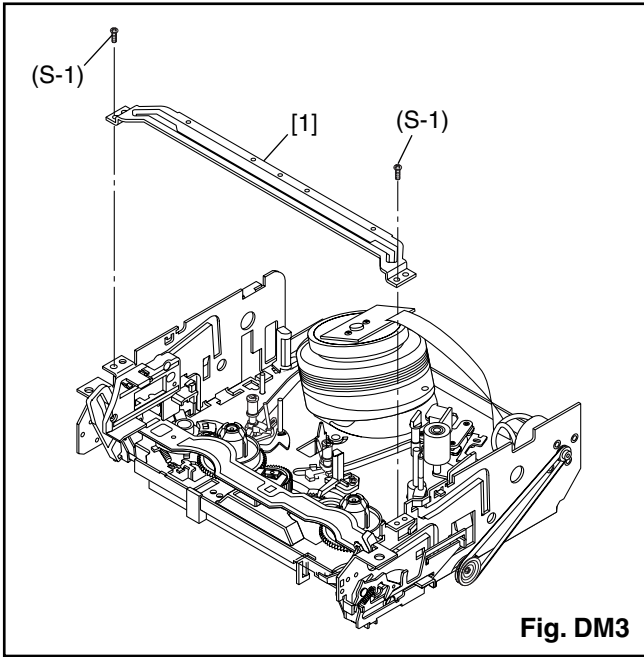

Fig. DM3

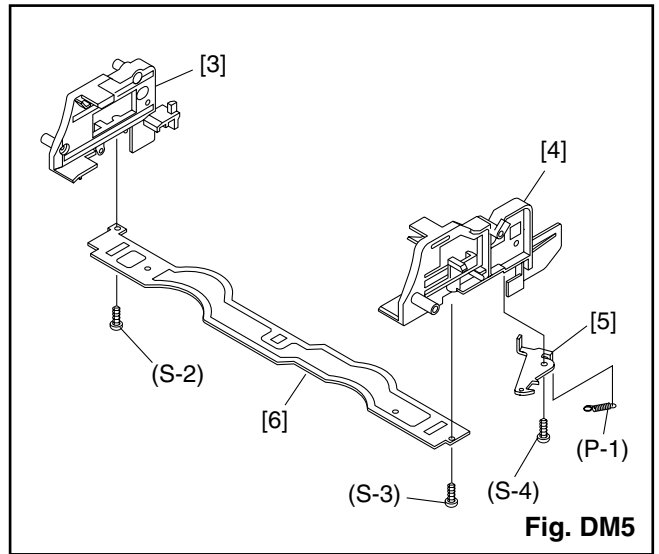
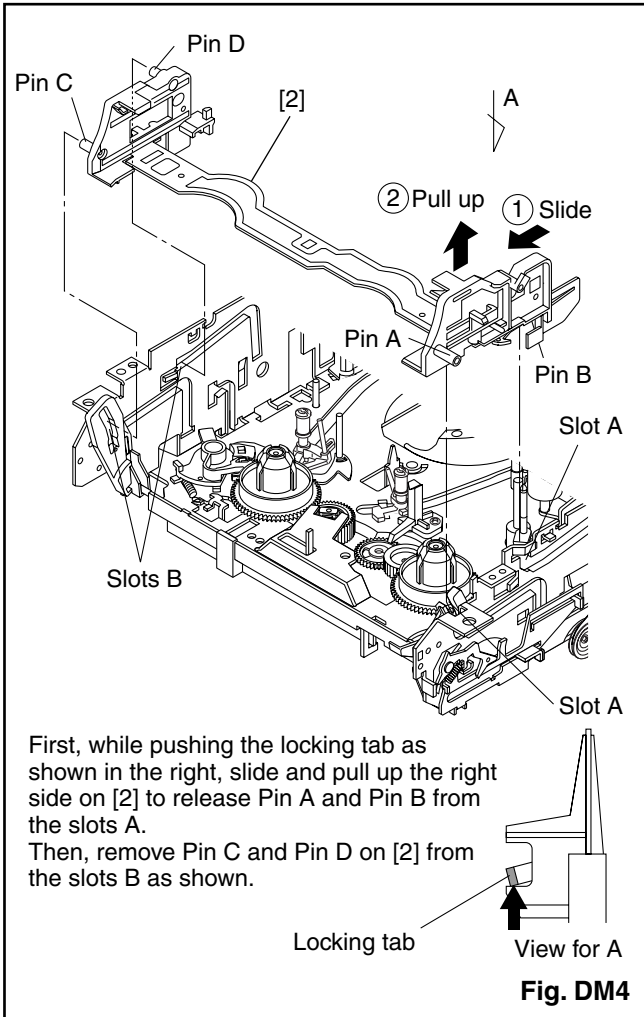

Fig. DM5



First, while pushing the locking tab as shown in the right, slide and pull up the right side on [2] to release Pin A and Pin B from the slots A.

Then, remove Pin C and Pin D on [2] from the slots B as shown.

Fig. DM4

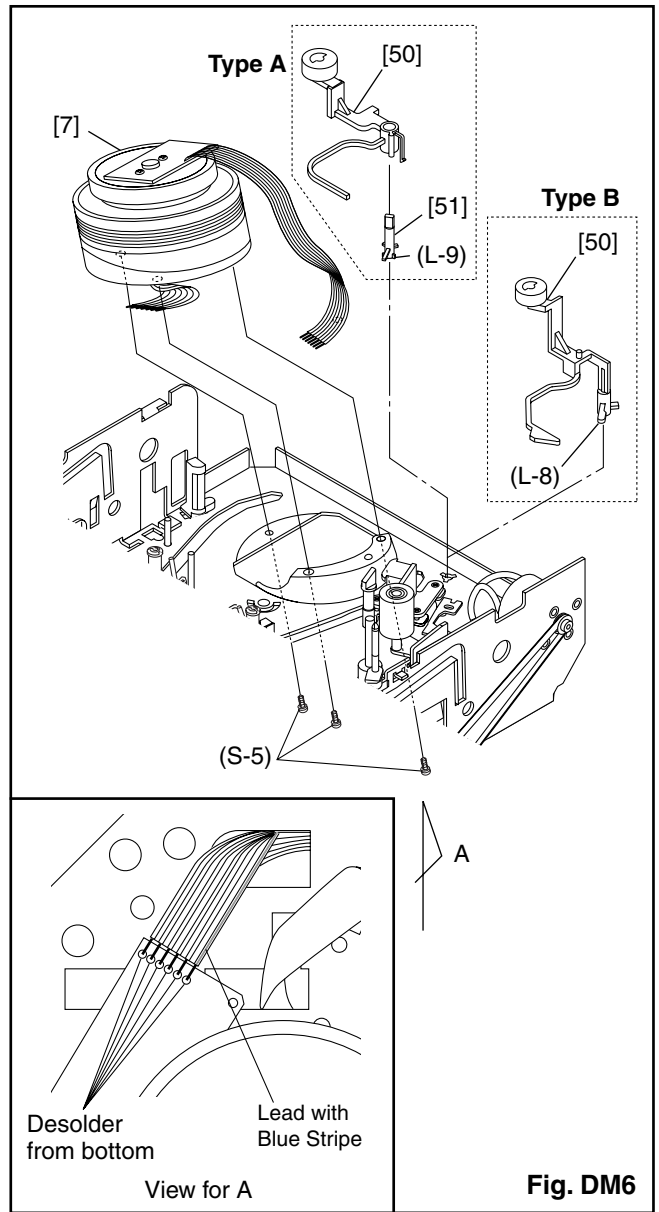
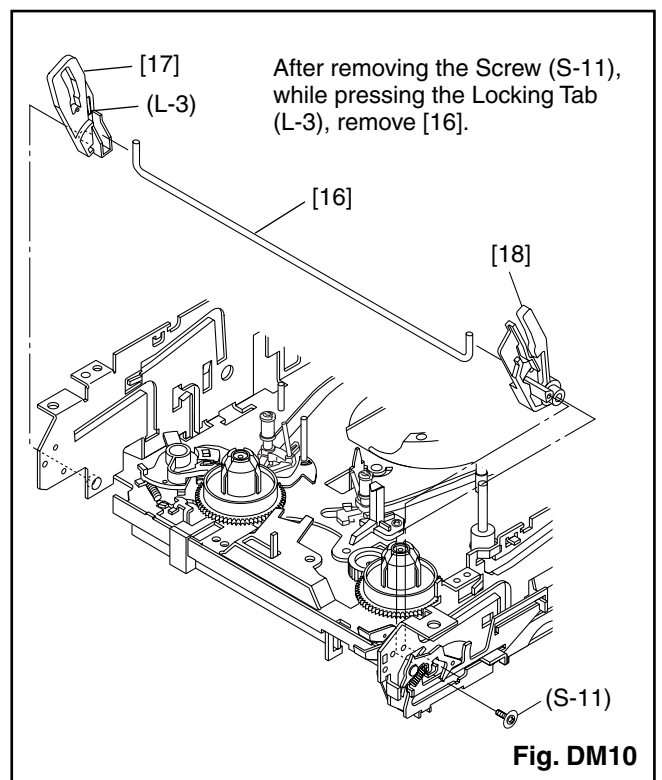
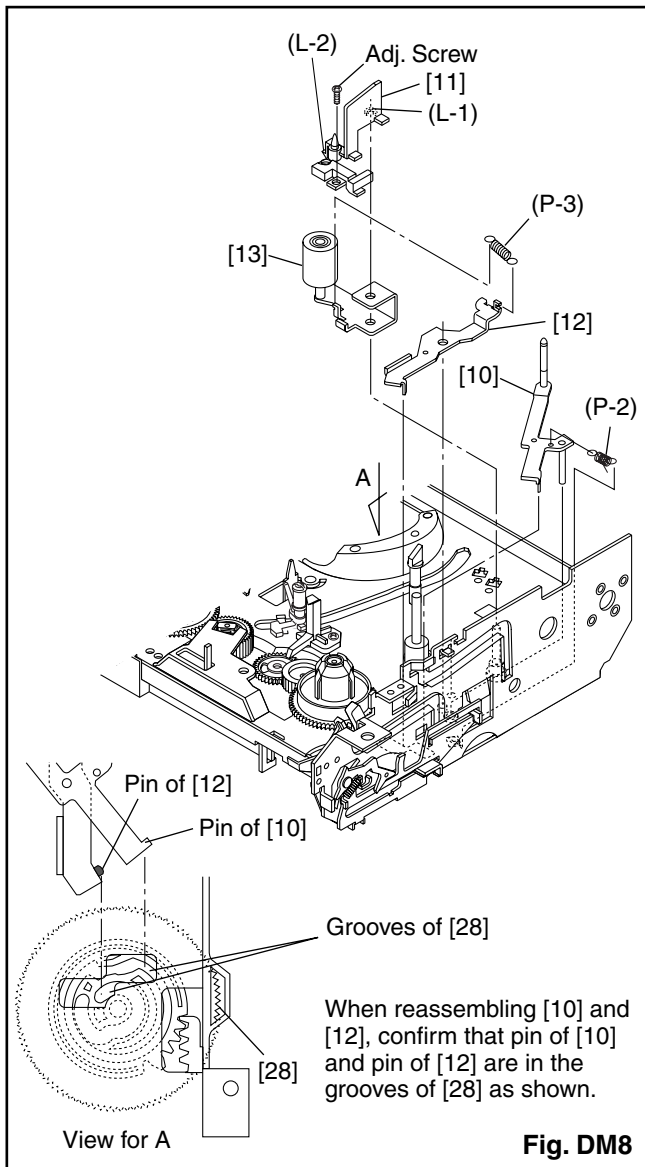
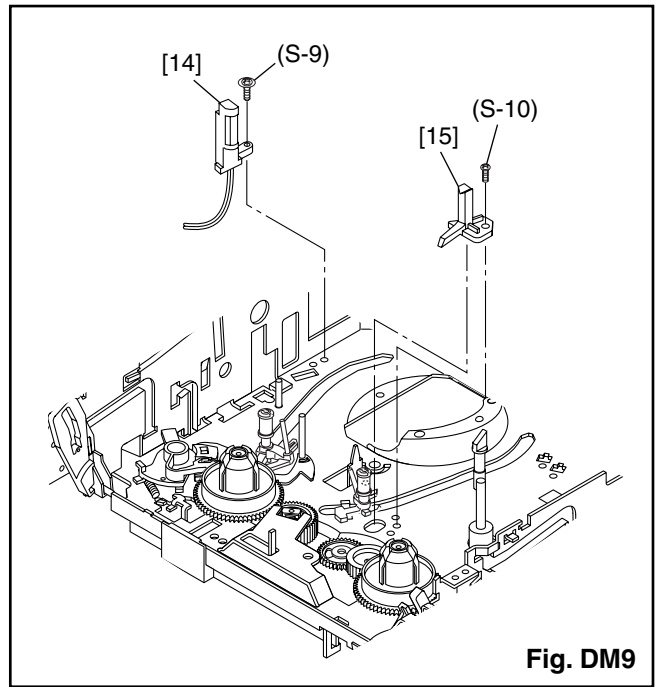
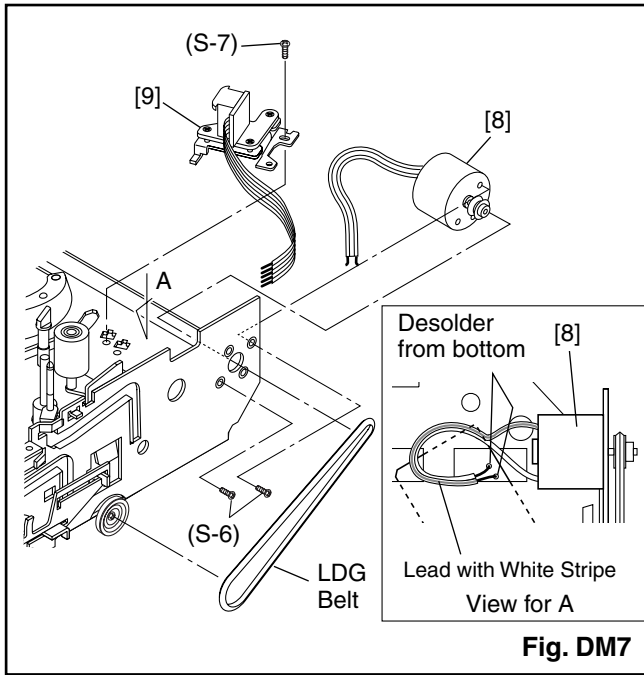
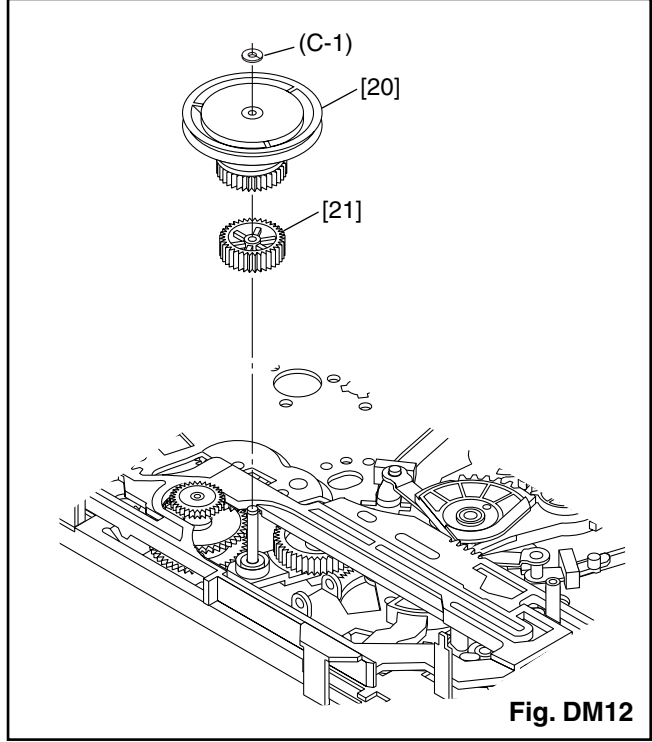
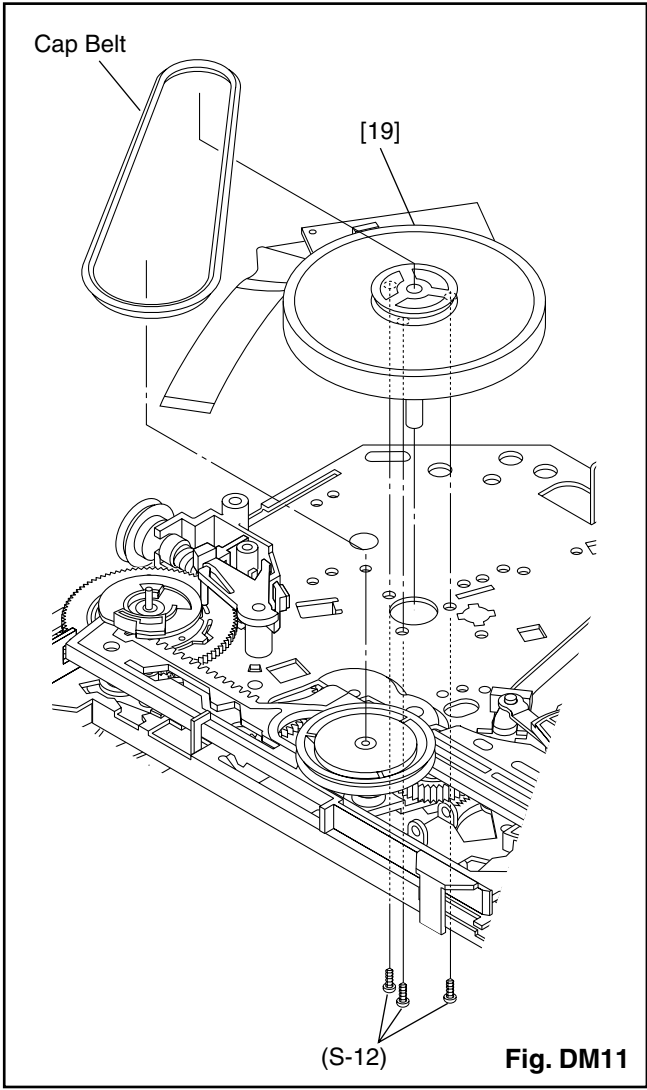
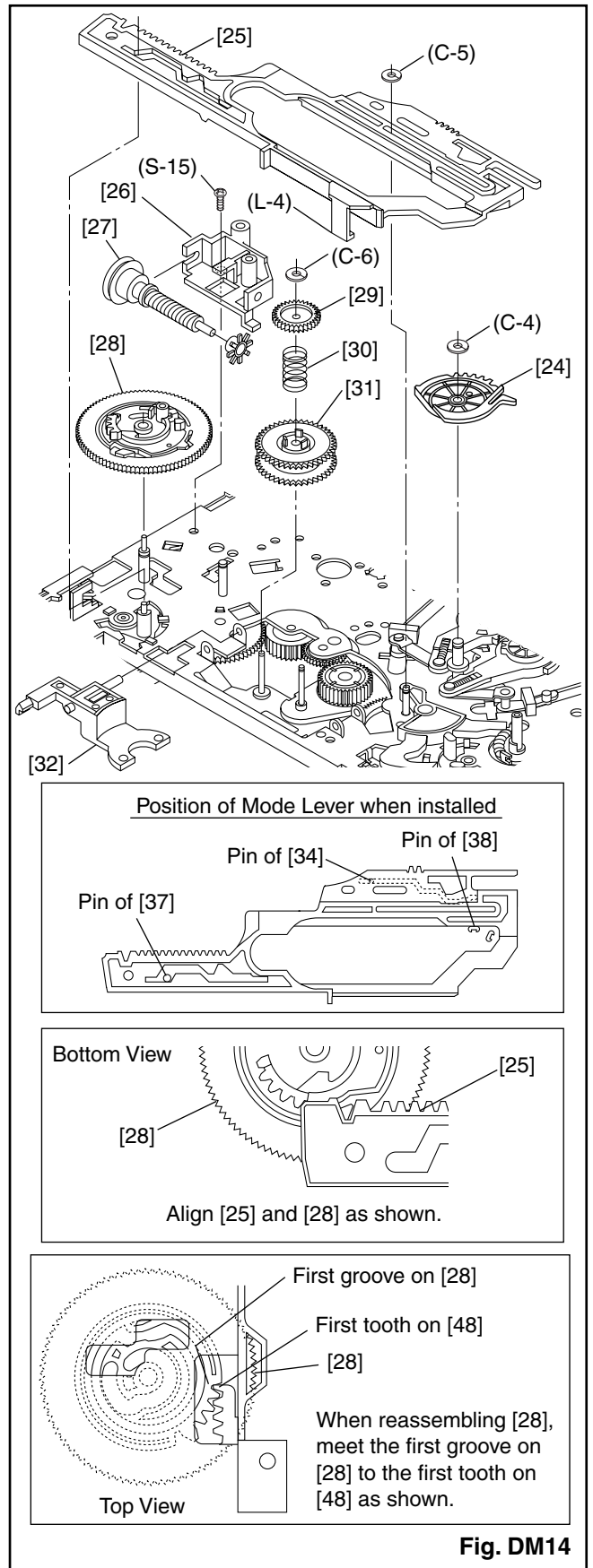
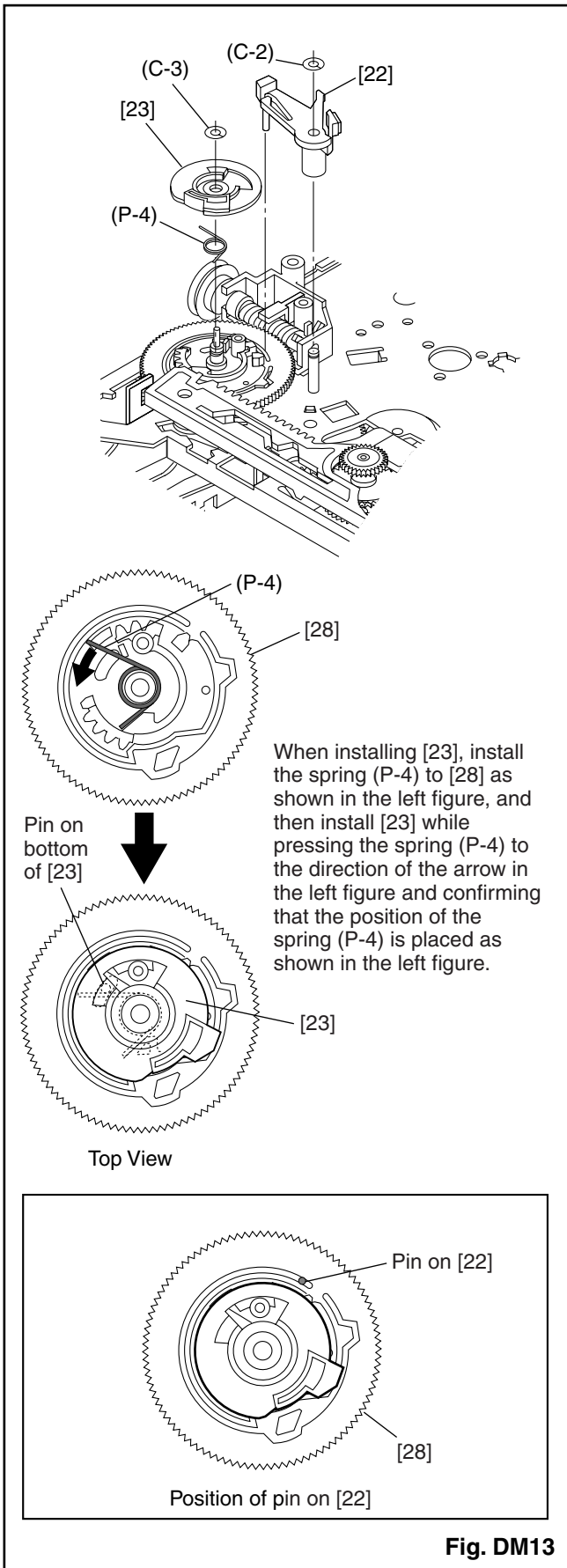
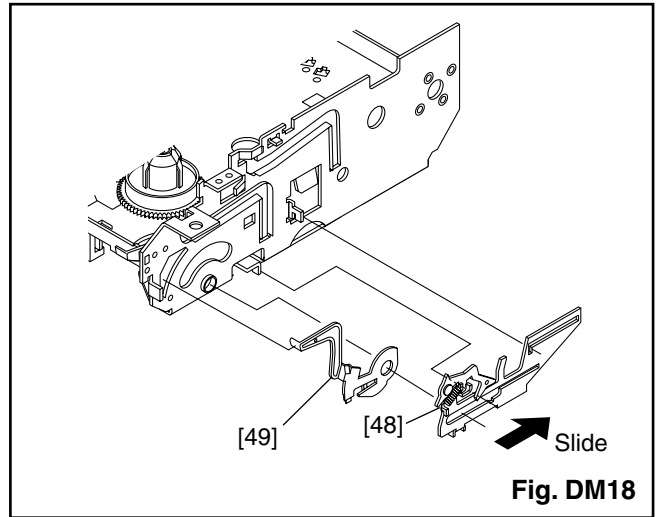
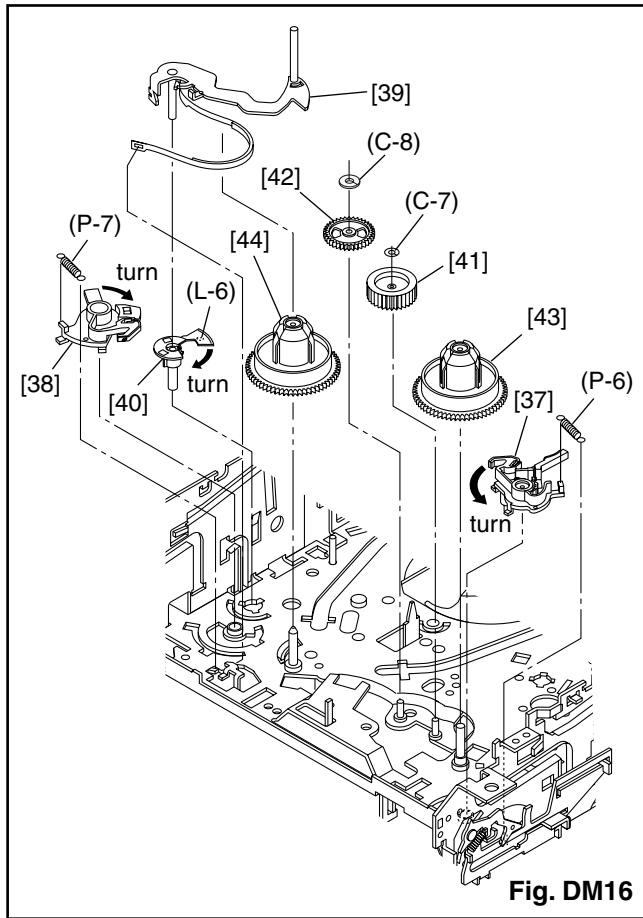
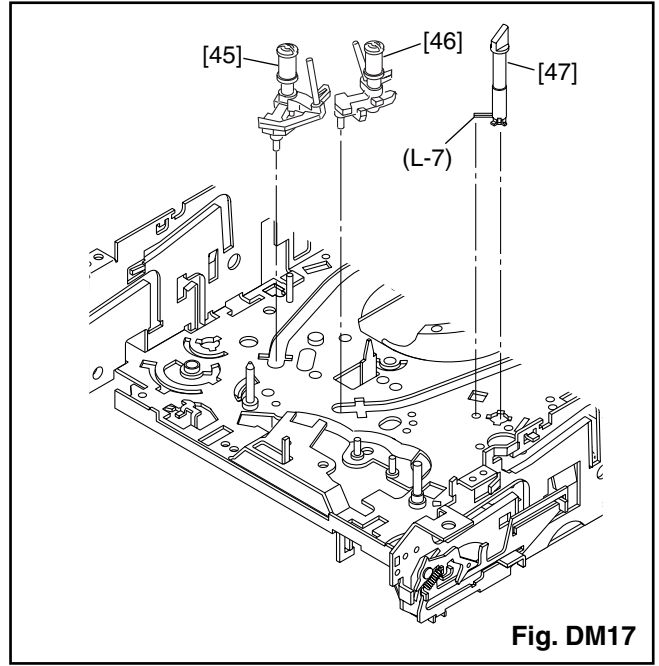
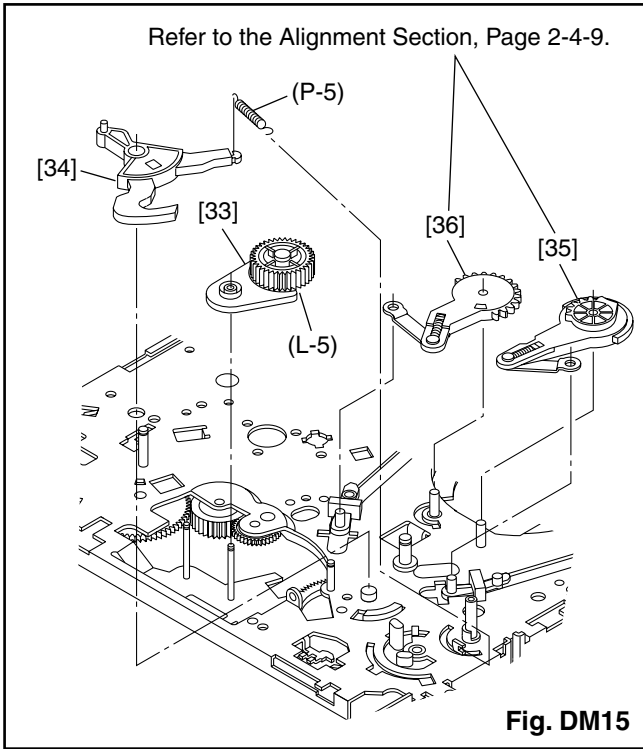

Fig. DM6









ALIGNMENT PROCEDURES OF MECHANISM

The following procedures describe how to align the individual gears and levers that make up the tape loading/unloading mechanism. Since information about the state of the mechanism is provided to the System Control Circuit only through the Mode Switch, it is essential that the correct relationship between individual gears and levers be maintained.

All alignments are to be performed with the mechanism in Eject mode, in the sequence given. Each procedure assumes that all previous procedures have been completed.

IMPORTANT:

If any one of these alignments is not performed properly, even if off by only one tooth, the unit will unload or stop and it may result in damage to the mechanical or electrical parts.

Alignment points in Eject Position

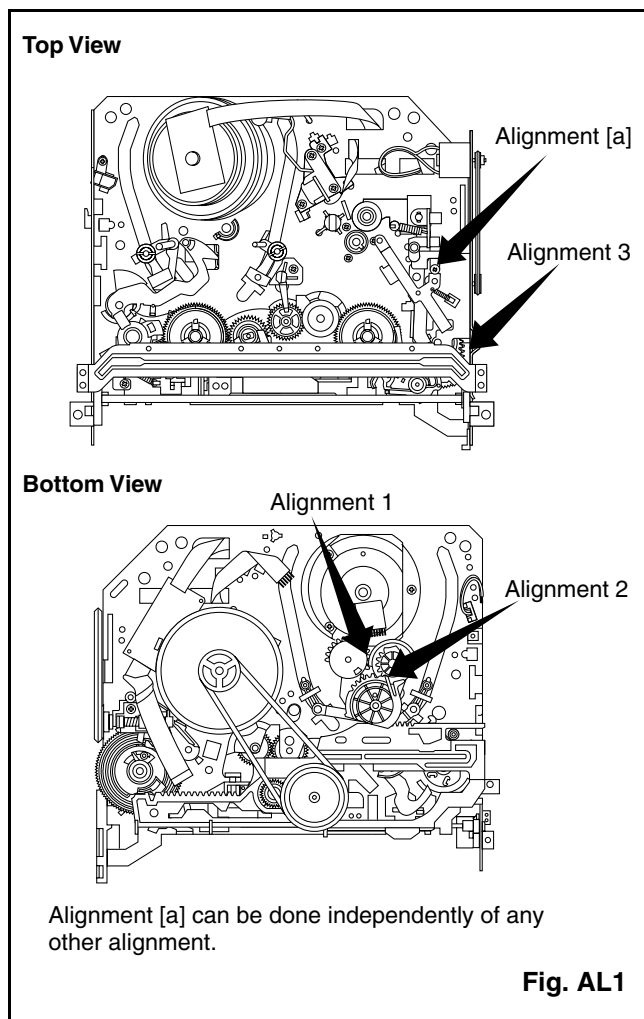

Alignment 1

Loading Arm, S and T Assembly

Install Loading Arm S and T Assembly so that their triangle marks point to each other as shown in Fig. AL2.

Alignment 2

Mode Gear

Keeping the two triangles pointing at each other, install the Loading Arm T Assembly so that the last tooth of the gear meets the most inside teeth of the Mode Gear. See Fig. AL2.

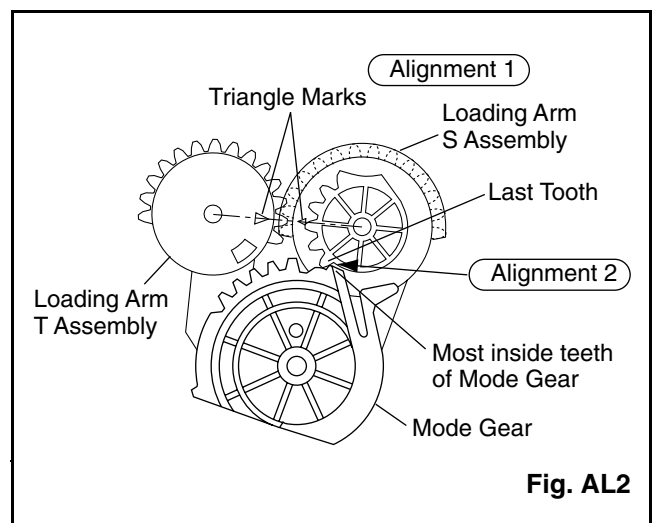

Alignment [a]

Tape Guide Assembly

Measurement of the screw must be as specified in Fig. AL3.

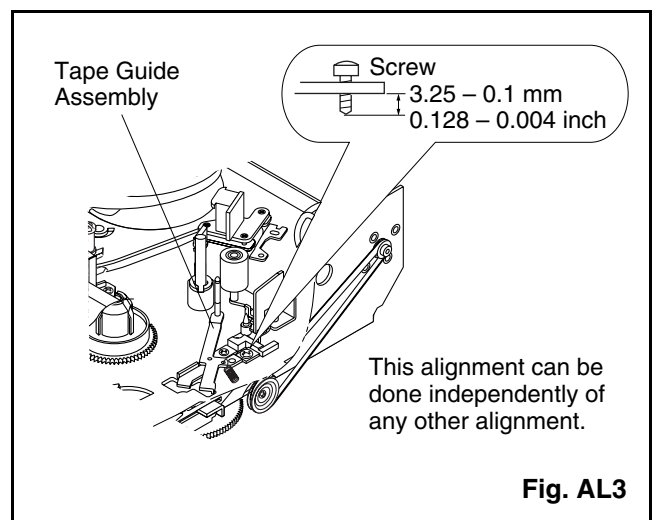

Alignment 3

Cam Gear (A), Rack Assembly

Install the Rack Assembly so that the first tooth on the gear of the Rack Assembly meets the first groove on the Cam Gear (A) as shown in Fig. AL4.

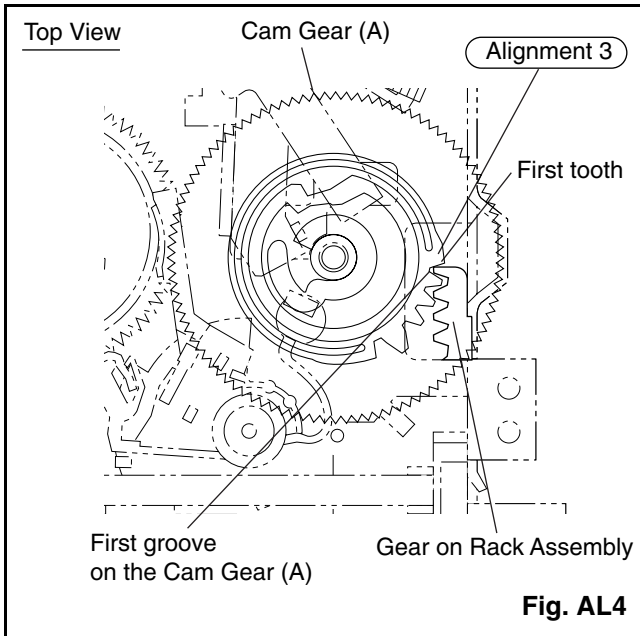
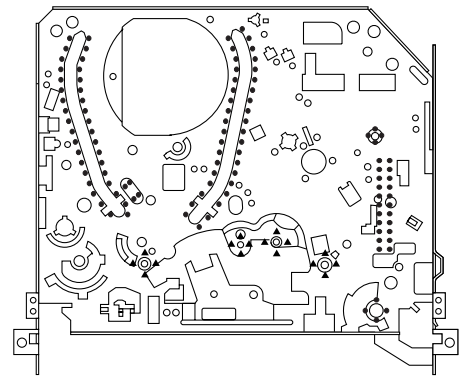
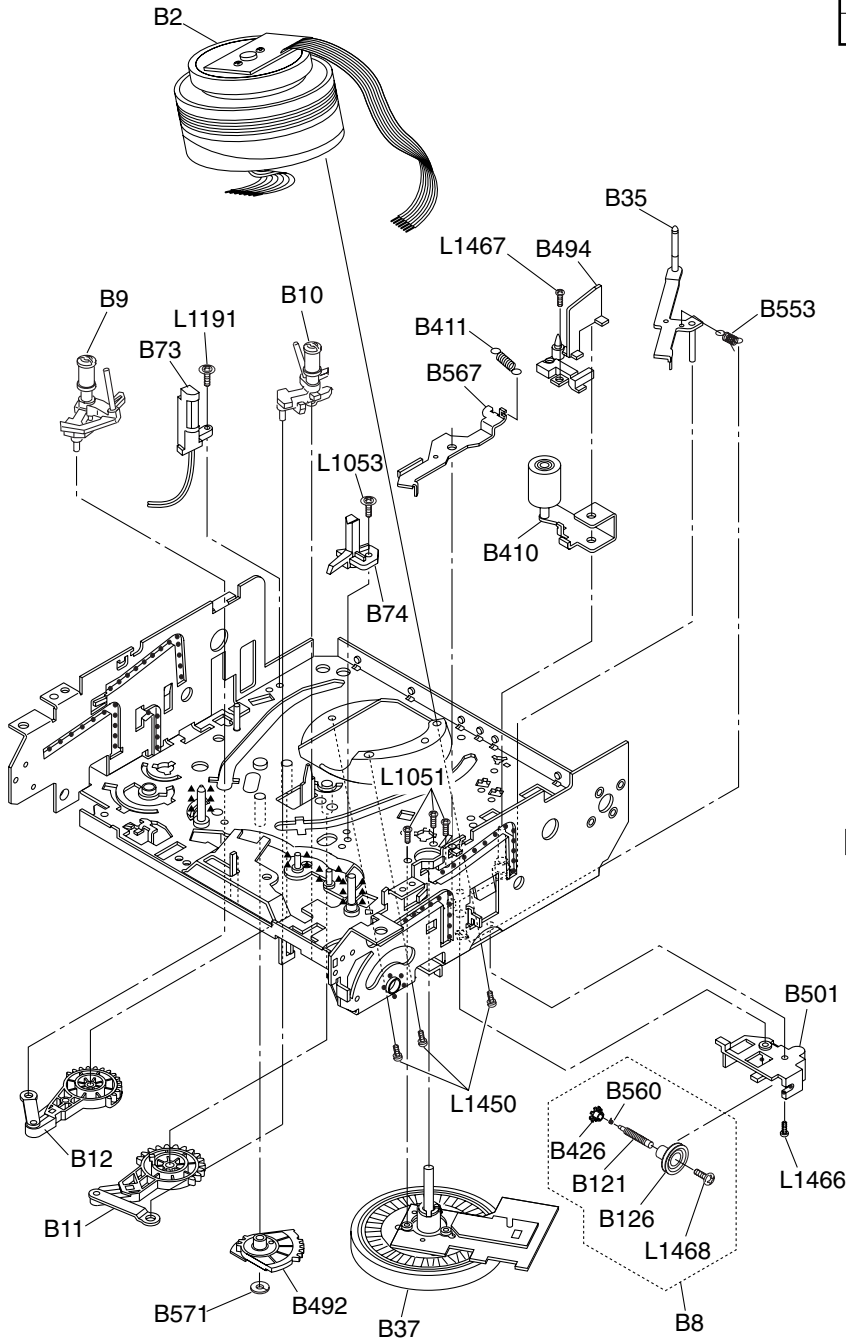

Fig. AL4

DECK EXPLODED VIEWS

Deck Mechanism View 1

Mark	Description
•••••	Floil G-374G (Blue grease)
▲▲▲▲▲	SLIDUS OIL #150



Chassis Assembly
Top View (Lubricating Point)

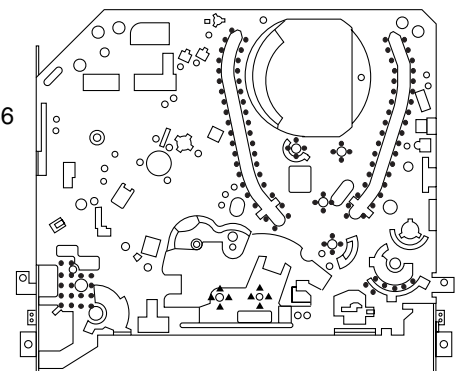

Chassis Assembly
Bottom View (Lubricating Point)

Some Ref. Numbers are not in sequence.

Deck Mechanism View 2

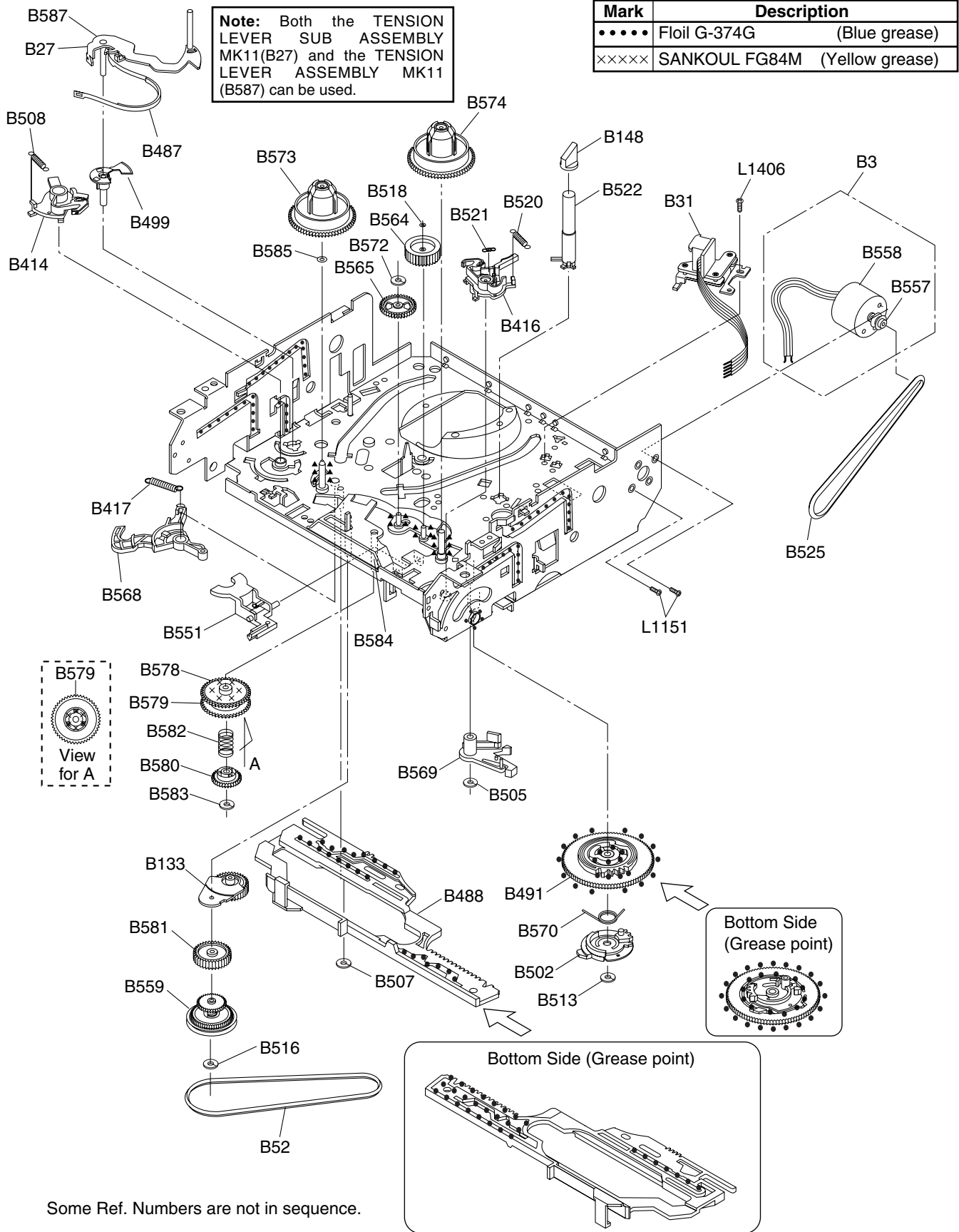

Deck Mechanism View 3

Mark	Description
•••••	Floil G-374G (Blue grease)

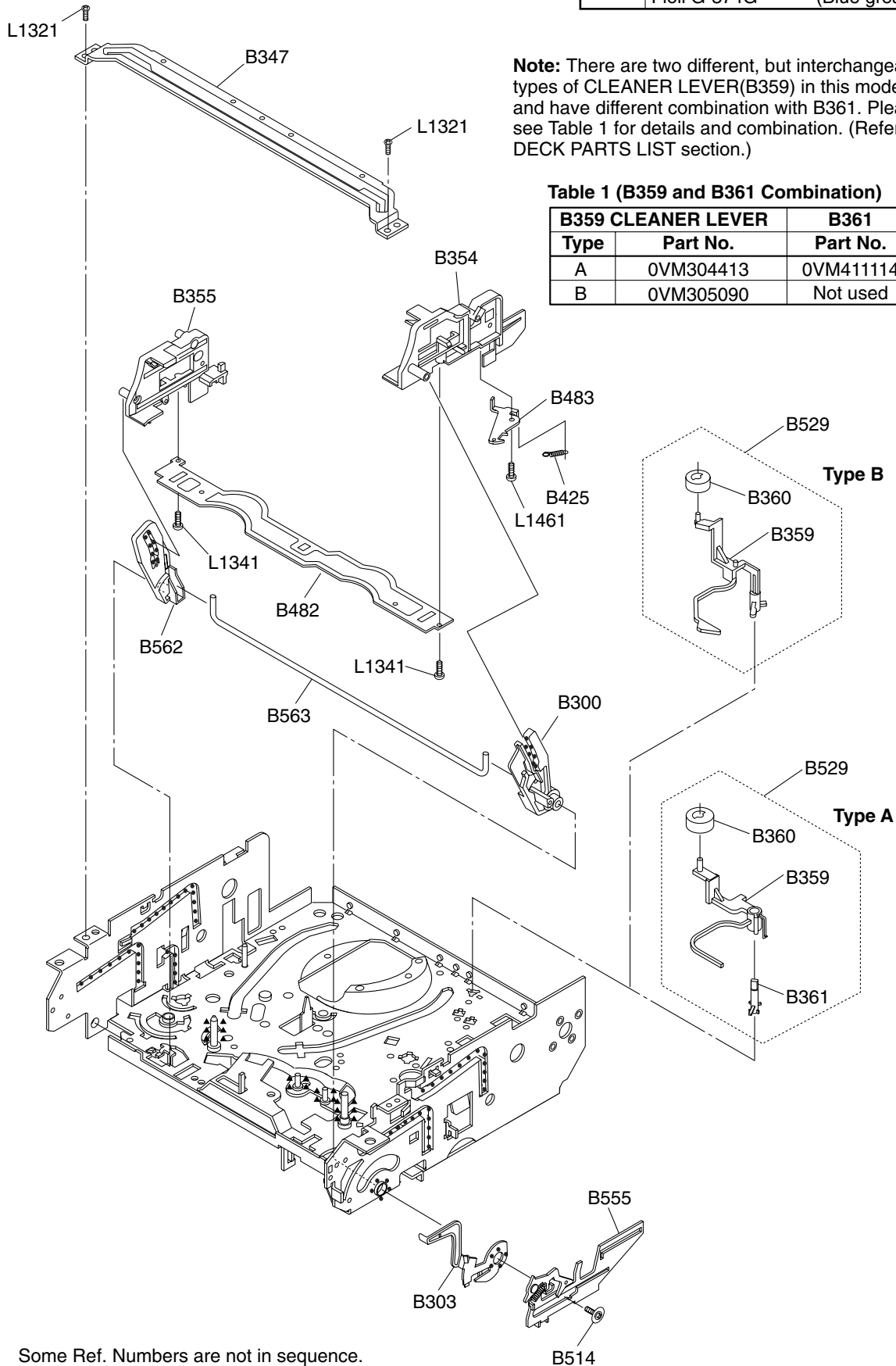

Note: There are two different, but interchangeable types of CLEANER LEVER(B359) in this model, and have different combination with B361. Please see Table 1 for details and combination. (Refer to DECK PARTS LIST section.)

Table 1 (B359 and B361 Combination)

B359 CLEANER LEVER		B361
Type	Part No.	Part No.
A	0VM304413	0VM411114
B	0VM305090	Not used

Some Ref. Numbers are not in sequence.

DECK PARTS LIST

Notes:

- There are two different, but interchangeable types of CLEANER LEVER(B359) in this model, and have different combination with B361. Please see Table 1 for details and combination.

Table 1 (B359 and B361 Combination)

B359 CLEANER LEVER		B361
Type	Part No.	Part No.
A	OVM304413	OVM411114
B	OVM305090	Not used

- There are two different types of RACK ASSEMBLY(B555), and have different combination with B514. Please see Table 2 for details and combination.

Table 2 (B555 and B514 Combination)

Carved Seal on Chassis (see below)	B555 RACK ASSEMBLY		B514
	Type	Part No.	Part No.
"1xx" or "2xx"	A	0VSA12071	OVM412597
"3xx" or "4xx"	B	0VSA12887	OVM411535

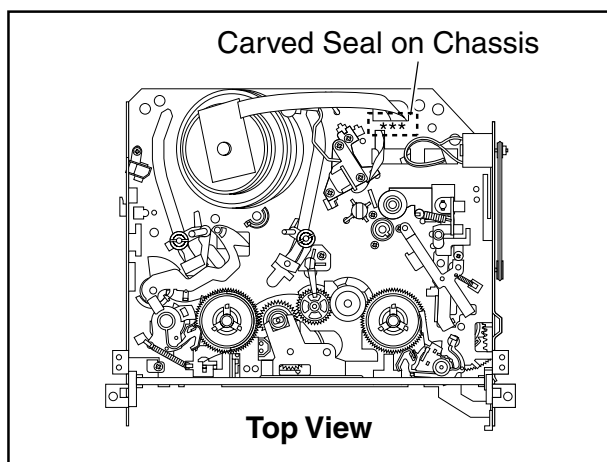

3. Comparison Chart of Models and Marks

Model	Mark
DVD740VR/001	A
DVD740VR/051	B

Ref. No.	Description	Part No.	A	B
B2	CYLINDER ASSEMBLY MK11 PAL 4HD HIFI or CYLINDER ASSEMBLY(V) MK11 PAL 4HD HIFI	N1567CYL N1569CYL	1	1
B3	LOADING MOTOR ASSEMBLY MK11	0VSA12093	1	1
B8	PULLEY ASSEMBLY MK11	0VSA12078	1	1
B9	MOVING GUIDE S PREPARATION MK10	0VSA11002	1	1
B10	MOVING GUIDE T PREPARATION MK10	0VSA11004	1	1
B11	LOADING ARM T(B) ASSEMBLY MK11	0VSA12110	1	1

Ref. No.	Description	Part No.	A	B
B12	LOADING ARM S(B) ASSEMBLY MK11	0VSA12109	1	1
B27	TENSION LEVER SUB ASSEMBLY MK11	0VSA12076A	1	1
B31	AC HEAD ASSEMBLY MK11	0VSA12074	1	1
B35	TAPE GUIDE ASSEMBLY MK11	0VSA12069	1	1
B37	CAPSTAN MOTOR 288/VCCM011	N9661CML	1	1
B52	CAP BELT MK10	OVM411138	1	1
B73	FE HEAD ASSEMBLY MK11 or FE HEAD(MK11) MH-131SF11 or FE HEAD ASSEMBLY MK11 or FE HEAD(MK11) VTR-1X2ERS11-148	N9742FEL DHVEC01Z0005 N9743FEL DHVEC01TE004	1	1
B74	PRISM MK10	OVM202870	1	1
B121	WORM MK11	OVM412544	1	1
B126	PULLEY MK11	OVM412543	1	1
B133	IDLER ASSEMBLY(2) MK10	0VSA11531	1	1
B148	TG CAP MK6	OVM407664C	1	1
B300	C DRIVE LEVER R MK11	OVM305068	1	1
B303	F DOOR OPENER MK11	OVM203299	1	1
B347	GUIDE HOLDER A MK10	OVM304920	1	1
B354	SLIDER R MK11	OVM101040	1	1
B355	SLIDER L MK11	OVM203296	1	1
B359	CLEANER LEVER MK10 or CLEANER LEVER MK11	OVM304413 OVM305090	1	1
B360	CLEANER ROLLER MK9	OVM410032C	1	1
B361	CL POST MK10	OVM411114	1	1
B410	PINCH ARM(A) ASSEMBLY(Y) MK11 or PINCH ARM(A) ASSEMBLY(M) MK11 or PINCH ARM(A) ASSEMBLY(F) MK11	0VSA12807 0VSA12808 0VSA12809	1	1
B411	PINCH SPRING MK10	OVM411092	1	1
B414	M BRAKE S(HI) ASSEMBLY MK11	0VSA12225	1	1
B416	M BRAKE T(HI) ASSEMBLY MK11	0VSA12226	1	1
B417	TENSION SPG(190256) MK11	OVM413624	1	1
B425	LOCK LEVER SPRING MK10	OVM411110	1	1
B426	KICK PULLEY MK10	OVM411095	1	1
B482	C PLATE MK11	OVM203297	1	1
B483	LOCK LEVER MK10	OVM411109D	1	1
B487	BAND BRAKE MK10	OVM304416B	1	1
B488	MODE LEVER(HI) MK11	OVM101042L	1	1
B491	CAM GEAR(A) MK11	OVM101044	1	1
B492	MODE GEAR MK11	OVM305074	1	1
B494	DOOR OPENER B MK11	OVM305072	1	1
B499	T LEVER HOLDER MK10	OVM304419	1	1
B501	WORM HOLDER MK11	OVM305067	1	1
B502	CAM GEAR(B) MK10	OVM304403	1	1
B505	PSCW(625504) MK11	OVM413288	1	1
B507	REEL WASHER MK9 5*2.1*0.5	OVM410058	1	1
B508	S BRAKE SPRING(19T) MK11	OVM413581	1	1
B513	PSCW(752605) MK10	OVM411516	1	1
B514	SCREW RACK MK11 or SCREW RACK MK10	OVM412597 OVM411535	1	1
B516	REEL WASHER MK9 5*2.1*0.5	OVM410058	1	1
B518	P.S.W CUT 1.6X4.0X0.5T	OVM408485A	1	1
B520	T BRAKE SPRING HI(F) MK11	OVM412778	1	1
B521	SOFT SPRING MK10	OVM411122	1	1
B522	TG POST ASSEMBLY MK10	0VSA11012	1	1
B525	LDG BELT MK11	OVM412804	1	1
B529	CLEANER ASSEMBLY MK11	0VSA12086	1	1
B551	FF ARM(HI) MK10	OVM304438L	1	1

Ref. No.	Description	Part No.	A	B
B553	REV SPRING MK11	0VM412555	1	1
B555	RACK ASSEMBLY MK11 or	0VSA12071	1	1
	RACK(T1.2) ASSEMBLY MK11	0VSA12887	1	1
B557	MOTOR PULLEY U5	0VM403205A	1	1
B558	LOADING MOTOR M31E-1 R14 7351	MMDZB12MM002	1	1
B559	CLUTCH ASSEMBLY(HI)(2) MK11	0VSA12367	1	1
B560	KICK SPRING MK10	0VM411475A	1	1
B562	C DRIVE LEVER L MK10	0VM304408	1	1
B563	SLIDER SHAFT MK10	0VM411112	1	1
B564	M GEAR(HYT) N12G5F*	0VM412378	1	1
B565	SENSOR GEAR MK11	0VM305080	1	1
B567	PINCH ARM(B) MK10	0VM304396	1	1
B568	BT ARM MK10	0VM304417H	1	1
B569	CAM HOLDER F MK11	0VM305075	1	1
B570	CAM RACK SPRING(HI) MK11	0VM412923	1	1
B571	P.S.W F 6*2.55*0.5	0VM402629A	1	1
B572	P.S.W CUT 1.6X4.0X0.5T	0VM408485A	1	1
B573	REEL S MK11	0VM203436	1	1
B574	REEL T MK10	0VM202872C	1	1
B578	TR GEAR A MK10	0VM304440	1	1
B579	TR GEAR B MK10	0VM304441C	1	1
B580	TR GEAR C MK11	0VM305094	1	1
B581	CENTER GEAR(HYT) N12G5F* or	0VM412379	1	1
	CENTER GEAR MK11	0VM305081	1	1
B582	TR GEAR SPRING MK10	0VM411187	1	1
B583	REEL WASHER MK9 5*2.1*0.5	0VM410058	1	1
B584	TR GEAR SHAFT MK10	0VM411186	1	1
B585	PSW(317505) MK11	0VM413663	1	1
B587	TENSION LEVER ASSEMBLY MK11	0VSA12075A	1	1
L1051	SCREW, B-TIGHT M2.6X6 PAN HEAD+	GPMB9060	1	1
L1053	SCREW, S-TIGHT M2.6X8 WASHER HEAD+	GCMS9080	1	1
L1151	SCREW, SEMS M2.6X4 PAN HEAD+	CPM39040	1	1
L1191	SCREW, S-TIGHT M2.6X8 WASHER HEAD+	GCMS9080	1	1
L1321	SCREW, S-TIGHT M3X6 BIND HEAD+	GBMS3060	1	1
L1341	SCREW, P-TIGHT M2.6X6 BIND HEAD+	GBMP9060	1	1
L1406	AC HEAD SCREW MK9	0VM410964	1	1
L1450	SCREW, SEMS M2.6X5 PAN HEAD+	CPM39050	1	1
L1461	SCREW, P-TIGHT M2.6X6 WASHER HEAD+	GCMP9060	1	1
L1466	SCREW, S-TIGHT M2.6X6 BIND HEAD+	GBMS9060	1	1
L1467	SCREW, S-TIGHT M2.6X5 WASHER HEAD+	GCMS9050	1	1
L1468	SCREW, B-TIGHT M1.7X12	GAMB7120	1	1

Spare Parts List

Mechanical /001

Various

A2	9965 000 14773	TOP COVER H9200UD
A4	9965 000 14774	PANEL, REAR H9330ED
A8	9965 000 14775	DOOR, CASSETTE H9330ED
A9	9965 000 09192	SPRING, DOOR H7220UD U15
X1	9965 000 14781	REMOTE CONTROL UNIT 364/CRC006
X3	4822 320 50377	CONNECT. CABLE PAL
X6	9965 000 14782	SCART CABLE 1.5M CE10130200857
1B1	9965 000 12399	DECK ASSEMBLY CZD011/VM15E0
1B2	9965 000 14777	DVD MECHA 0838 VCDVM030
2B1	9965 000 14778	DECK PEDESTAL-1 H9200UD
2B6	9965 000 14779	DECK PEDESTAL-2 H9200UD
A1X	9965 000 14772	FRONT ASSEMBLY H9330ED
A20	9965 000 14776	TRAY PANEL ASSEMBLY H9231CD
1000	9965 000 14793	DVD MAIN CBA UNIT
1001	9965 000 14794	MHz V CBA /001
1002	9965 000 14795	POWER SUPPLY CBA
1009	9965 000 14770	AFV CBA /001

-II-

2B40	9965 000 14780	INSULATOR H9311BD
AC1001	9965 000 14851	AC CORD PE8B2CB980A-057
X20A!	9965 000 14783	OWNER'S MANUAL(E) H9330ED
X20B!	9965 000 14784	OWNER'S MANUAL(G) H9330ED
X20C!	9965 000 14785	OWNER'S MANUAL(D) H9330ED
X20D!	9965 000 14786	OWNER'S MANUAL(F) H9330ED
X20E!	9965 000 14787	OWNER'S MANUAL(S) H9330ED
X20F!	9965 000 14788	OWNER'S MANUAL(P) H9330ED
X20G!	9965 000 14789	OWNER'S MANUAL(I) H9330ED
X20H!	9965 000 14790	OWNER'S MANUAL(GE) H9330ED
X20I!	9965 000 14791	OWNER'S MANUAL(SW) H9330ED
X20J!	9965 000 14792	OWNER'S MANUAL(FI) H9330ED

Mechanical /051

Various

A2	9965 000 14773	TOP COVER H9200UD
A4	9965 000 15345	PANEL, REAR H9331BD
A8	9965 000 14775	DOOR, CASSETTE H9330ED
A9	9965 000 09192	SPRING, DOOR H7220UD U15
X1	9965 000 15346	REMOTE CONTROL UNIT 364/CRC006
X3	4822 320 50377	CONNECT. CABLE PAL
X6	9965 000 14782	SCART CABLE 1.5M CE10130200857
1B1	9965 000 12399	DECK ASSEMBLY CZD011/VM15E0
1B2	9965 000 14777	DVD MECHA 0838 VCDVM030
2B1	9965 000 14778	DECK PEDESTAL-1 H9200UD
2B6	9965 000 14779	DECK PEDESTAL-2 H9200UD
A1X	9965 000 15344	FRONT ASSEMBLY H9331BD
A20	9965 000 14776	TRAY PANEL ASSEMBLY H9231CD
1000	9965 000 14793	DVD MAIN CBA UNIT
1001	9965 000 15349	MHz V CBA /051
1002	9965 000 14795	POWER SUPPLY CBA
1009	9965 000 14770	AFV CBA /001

-II-

2B40	9965 000 14780	INSULATOR H9311BD
AC1001	9965 000 15347	AC CORD PQ8B1V5980A-05B
X20A!	9965 000 15348	OWNER'S MANUAL H9331BD

MCV CBA /051

Various

1008	9965 000 14801	SENSOR CBA
------	----------------	------------

Main CBA /051

-II-

C055	9965 000 15242	ELECTROLYTIC . 100µF /25V M
C056	9965 000 14863	ELECTROLYTIC . 47µF /25V M
C058	9965 000 15243	ELECTRIC DOUBLE LAYER 0.047
C063	9965 000 15244	ELECTROLYTIC . 47µF /16V M
C101	9965 000 15245	ELECTROLYTIC . 4.7µF /50V M
C102	9965 000 15245	ELECTROLYTIC . 4.7µF /50V M
C103	9965 000 15245	ELECTROLYTIC . 4.7µF /50V M
C104	9965 000 15246	ELECTROLYTIC . 100µF /16V M

C107	9965 000 14862	ELECTROLYTIC . 470µF /6.3V M
C108	9965 000 14862	ELECTROLYTIC . 470µF /6.3V M
C117	9965 000 15289	ELECTROLYTIC . 1µF /50V M
C121	9965 000 15246	ELECTROLYTIC . 100µF /16V M
C251	9965 000 15290	ELECTROLYTIC . 10µF /16V M H
C254	9965 000 15291	ELECTROLYTIC . 1µF /50V M H7
C302	9965 000 15291	ELECTROLYTIC . 1µF /50V M H7
C305	9965 000 15291	ELECTROLYTIC . 1µF /50V M H7
C312	9965 000 15290	ELECTROLYTIC . 10µF /16V M H
C313	9965 000 15291	ELECTROLYTIC . 1µF /50V M H7
C316	9965 000 15291	ELECTROLYTIC . 1µF /50V M H7
C328	9965 000 15292	ELECTROLYTIC . 47µF /6.3V M
C330	9965 000 15293	ELECTROLYTIC . 100µF /16V M
C331	9965 000 15294	ELECTROLYTIC . 220µF /6.3V M
C334	9965 000 15291	ELECTROLYTIC . 1µF /50V M H7
C335	9965 000 15295	ELECTROLYTIC . 100µF /6.3V H
C340	9965 000 15291	ELECTROLYTIC . 1µF /50V M H7
C343	9965 000 15290	ELECTROLYTIC . 10µF /16V M H
C344	9965 000 15296	ELECTROLYTIC . 4.7µF /25V M
C345	9965 000 15297	ELECTROLYTIC . 0.47µF /50V M
C405	9965 000 15292	ELECTROLYTIC . 47µF /6.3V M
C406	9965 000 15298	ELECTROLYTIC . 4.7µF /25V M
C410	9965 000 15290	ELECTROLYTIC . 10µF /16V M H
C412	9965 000 15299	ELECTROLYTIC . 33µF /6.3V M
C415	9965 000 15298	ELECTROLYTIC . 4.7µF /25V M
C417	9965 000 15300	ELECTROLYTIC . 22µF /6.3V M
C421	9965 000 15292	ELECTROLYTIC . 47µF /6.3V M
C451	9965 000 15298	ELECTROLYTIC . 4.7µF /25V M
C454	9965 000 15301	ELECTROLYTIC . 2.2µF /50V M
C455	9965 000 15301	ELECTROLYTIC . 2.2µF /50V M
C456	9965 000 15290	ELECTROLYTIC . 10µF /16V M H
C457	9965 000 15298	ELECTROLYTIC . 4.7µF /25V M
C458	9965 000 15298	ELECTROLYTIC . 4.7µF /25V M
C459	9965 000 15298	ELECTROLYTIC . 4.7µF /25V M
C460	9965 000 15302	ELECTROLYTIC . 47µF /16V M H
C462	9965 000 15290	ELECTROLYTIC . 10µF /16V M H
C463	9965 000 15290	ELECTROLYTIC . 10µF /16V M H
C468	9965 000 15290	ELECTROLYTIC . 10µF /16V M H
C469	9965 000 15303	ELECTROLYTIC . 22µF /10V M H
C470	9965 000 15298	ELECTROLYTIC . 4.7µF /25V M
C471	9965 000 15290	ELECTROLYTIC . 10µF /16V M H
C473	9965 000 15298	ELECTROLYTIC . 4.7µF /25V M
C475	9965 000 15303	ELECTROLYTIC . 22µF /10V M H
C478	9965 000 15303	ELECTROLYTIC . 22µF /10V M H
C479	9965 000 15298	ELECTROLYTIC . 4.7µF /25V M
C480	9965 000 15290	ELECTROLYTIC . 10µF /16V M H
C506	9965 000 15294	ELECTROLYTIC . 220µF /6.3V M
C511	4822 126 12787	330pF 10% 50V
C514	4822 126 12787	330pF 10% 50V
C516	9965 000 15300	ELECTROLYTIC . 22µF /6.3V M
C521	9965 000 15300	ELECTROLYTIC . 22µF /6.3V M
C534	9965 000 15292	ELECTROLYTIC . 47µF /6.3V M
C549	9965 000 15291	ELECTROLYTIC . 1µF /50V M H7
C550	9965 000 15295	ELECTROLYTIC . 100µF /6.3V H
C553	9965 000 15303	ELECTROLYTIC . 22µF /10V M H
C632	9965 000 15291	ELECTROLYTIC . 1µF /50V M H7
C633	9965 000 15291	ELECTROLYTIC . 1µF /50V M H7
C635	9965 000 12290	SEMICONDUCTOR . SR K 0.056U
C636	9965 000 15298	ELECTROLYTIC . 4.7µF /25V M
C637	9965 000 15292	ELECTROLYTIC . 47µF /6.3V M
C701	9965 000 15295	ELECTROLYTIC . 100µF /6.3V H
C708	9965 000 15290	ELECTROLYTIC . 10µF /16V M H
C752	9965 000 15304	ELECTROLYTIC . 47µF /10V M
C753	9965 000 15245	ELECTROLYTIC . 4.7µF /50V M
C754	9965 000 15245	ELECTROLYTIC . 4.7µF /50V M

→

D051	4822 157 10332	
D052	5322 130 81917	SB140
D053	4822 130 31933	1N5061
D054	9965 000 09283	ZENER DIODE DZ-10BSBT265
D055	4822 130 31933	1N5061
D056	4822 130 30621	1N4148
D057	5322 130 81917	SB140
D101	9965 000 12178	ZENER DIODE DZ-11BSAT265
D102	9965 000 12178	ZENER DIODE DZ-11BSAT265
D103	9965 000 12178	ZENER DIODE DZ-11BSAT265
D104	9965 000 12178	ZENER DIODE DZ-11BSAT265
D105	9965 000 12178	ZENER DIODE DZ-11BSAT265
D106	9965 000 12178	ZENER DIODE DZ-11BSAT265
D107	9965 000 12178	ZENER DIODE DZ-11BSAT265
D108	9965 000 12178	ZENER DIODE DZ-11BSAT265
D109	9965 000 12178	ZENER DIODE DZ-11BSAT265
D110	9965 000 12178	ZENER DIODE DZ-11BSAT265
D112	9965 000 12178	ZENER DIODE DZ-11BSAT265
D113	9965 000 12178	ZENER DIODE DZ-11BSAT265
D115	9965 000 12178	ZENER DIODE DZ-11BSAT265
D118	9965 000 12178	ZENER DIODE DZ-11BSAT265

D119 9965 000 12178 ZENER DIODE DZ-11BSAT265
D121 9965 000 12178 ZENER DIODE DZ-11BSAT265
D301 4822 130 30621 1N4148
D506 9965 000 08623 LED(GREEN) 204-10GD/S957
D507 9965 000 08623 LED(GREEN) 204-10GD/S957
D508 9965 000 08621 LED(RED) 204HD/E
D510 4822 130 30621 1N4148
D511 9965 000 15309 ZENER DIODE DZ-7.5BSAT265
D512 4822 130 30621 1N4148
D513 4822 130 30621 1N4148
D555 9965 000 05250 LED SIR-563ST3F P
D701 9965 000 09183 ZENER DIODE DZ-33BSDT265
D751 9965 000 15310 ZENER DIODE DZ-8.2BSAT265

L051 4822 157 10332
L052 9965 000 05627 CHOKE COIL 47μH -K
L053 4822 157 10649 100μH
L101 4822 526 10685 BEAD CORE
L102 4822 526 10685 BEAD CORE
L251 9965 000 08652 INDUCTOR 5.6μH -K-26T
L302 4822 157 63316
L401 9965 000 05627 CHOKE COIL 47μH -K
L402 9965 000 05705 INDUCTOR 47μH -K-5FT
L451 9965 000 05627 CHOKE COIL 47μH -K
L452 9965 000 05627 CHOKE COIL 47μH -K
L501 4822 157 10649 100μH
L502 4822 157 10332
L503 9965 000 08629 INDUCTOR 1.8μH -K-26T
L701 4822 157 11511 15μH -K-26T
L702 4822 157 10332
L703 9965 000 05627 CHOKE COIL 47μH -K
L704 4822 157 10889 10μH



Q051 9965 000 12190 TRANSISTOR KTA1281(Y)
Q052 4822 130 10098 KRC103M
Q053 4822 130 42292 2SC2120Y
Q054 4822 130 10098 KRC103M
Q055 4822 130 10103 KTC3199Y
Q056 4822 130 42292 2SC2120Y
Q057 4822 130 10145 KRA103M
Q101 4822 130 10103 KTC3199Y
Q102 4822 130 10103 KTC3199Y
Q103 4822 130 42959 2SA1015Y
Q104 4822 130 42959 2SA1015Y
Q105 4822 130 10103 KTC3199Y
Q301 4822 130 42959 2SA1015Y
Q302 4822 130 10103 KTC3199Y
Q401 4822 130 10103 KTC3199Y
Q402 4822 130 10103 KTC3199Y
Q403 4822 130 42292 2SC2120Y
Q404 4822 130 42959 2SA1015Y
Q405 4822 130 10145 KRA103M
Q406 4822 130 10103 KTC3199Y
Q451 4822 130 10098 KRC103M
Q501 4822 130 10103 KTC3199Y
Q502 4822 130 10103 KTC3199Y
Q506 9965 000 08630 PHOTO TRANSISTOR PT204-6B-12
Q507 4822 130 10103 KTC3199Y
Q508 4822 130 10103 KTC3199Y
Q509 4822 130 10103 KTC3199Y
Q510 4822 130 10098 KRC103M
Q511 4822 130 10103 KTC3199Y
Q513 4822 130 10098 KRC103M
Q514 4822 130 10923 KTC3199(BL)
Q515 4822 130 10923 KTC3199(BL)
Q752 4822 130 10098 KRC103M



R054 4822 051 30223 22k 5% 0,062W
R064 4822 157 10332
R065 4822 051 30223 22k 5% 0,062W
R101 4822 117 12925 47k 1% 0.063W 0603
R102 4822 117 12925 47k 1% 0.063W 0603
R122 4822 051 30103 10k 5% 0,062W
R134 9965 000 10005 CHIP RES.(1608) 1/10W J 22 Ω
R140 4822 051 30223 22k 5% 0,062W
R251 4822 051 30393 39k 5% 0,062W
R301 9965 000 09966 CHIP RES.(1608) 1/10W J 390k Ω
R303 4822 051 30562 5k6 5% 0,063W 0603 RC21 RST SM
R304 9965 000 09942 CHIP RES.(1608) 1/16W J 330k Ω
R305 4822 051 30103 10k 5% 0,062W
R315 9965 000 13036 CHIP RES.(1608) 1/10W J 1k Ω
R319 9965 000 13036 CHIP RES.(1608) 1/10W J 1k Ω
R320 4822 051 30393 39k 5% 0,062W
R322 4822 051 30103 10k 5% 0,062W
R325 9965 000 09966 CHIP RES.(1608) 1/10W J 390k Ω
R327 9965 000 10005 CHIP RES.(1608) 1/10W J 22 Ω

R328 4822 051 30561 560Ω 5% 0,062W
R331 4822 051 30183 18k 5% 0,062W
R332 4822 051 30103 10k 5% 0,062W
R333 4822 051 30183 18k 5% 0,062W
R334 4822 051 30103 10k 5% 0,062W
R337 9965 000 10005 CHIP RES.(1608) 1/10W J 22 Ω
R339 9965 000 09942 CHIP RES.(1608) 1/16W J 330k Ω
R403 4822 051 30103 10k 5% 0,062W
R404 4822 051 30103 10k 5% 0,062W
R405 4822 117 12925 47k 1% 0.063W 0603
R406 4822 051 30223 22k 5% 0,062W
R407 4822 051 30562 5k6 5% 0,063W 0603 RC21 RST SM
R409 4822 051 30562 5k6 5% 0,063W 0603 RC21 RST SM
R410 9965 000 13036 CHIP RES.(1608) 1/10W J 1k Ω
R413 4822 051 30334 330k 5% 0,062W
R416 9965 000 09966 CHIP RES.(1608) 1/10W J 390k Ω
R419 4822 051 30103 10k 5% 0,062W
R420 9965 000 09214 CARBON RES. 1/6W J 5.6k Ω
R452 9965 000 10005 CHIP RES.(1608) 1/10W J 22 Ω
R453 9965 000 10005 CHIP RES.(1608) 1/10W J 22 Ω
R454 9965 000 10005 CHIP RES.(1608) 1/10W J 22 Ω
R455 4822 051 30393 39k 5% 0,062W
R456 4822 051 30393 39k 5% 0,062W
R458 9965 000 13036 CHIP RES.(1608) 1/10W J 1k Ω
R459 9965 000 13036 CHIP RES.(1608) 1/10W J 1k Ω
R460 9965 000 10005 CHIP RES.(1608) 1/10W J 22 Ω
R461 4822 051 30223 22k 5% 0,062W
R462 4822 117 12902 8k2 1% 0.063W 0603
R463 9965 000 10005 CHIP RES.(1608) 1/10W J 22 Ω
R464 4822 051 30393 39k 5% 0,062W
R465 4822 051 30393 39k 5% 0,062W
R466 4822 117 12902 8k2 1% 0.063W 0603
R467 9965 000 10005 CHIP RES.(1608) 1/10W J 22 Ω
R468 4822 051 30393 39k 5% 0,062W
R469 4822 051 30393 39k 5% 0,062W
R470 9965 000 10005 CHIP RES.(1608) 1/10W J 22 Ω
R471 4822 117 12902 8k2 1% 0.063W 0603
R475 4822 051 30471 470Ω 5% 0,062W
R476 4822 051 30103 10k 5% 0,062W
R502 9965 000 13036 CHIP RES.(1608) 1/10W J 1k Ω
R503 9965 000 09966 CHIP RES.(1608) 1/10W J 390k Ω
R504 4822 051 30152 1k5 5% 0,062W
R507 4822 117 12902 8k2 1% 0.063W 0603
R523 4822 116 52243 1k5 5% 0,5W
R537 4822 051 30681 680Ω 5% 0,062W
R538 4822 051 30152 1k5 5% 0,062W
R539 4822 051 30103 10k 5% 0,062W
R540 4822 051 30103 10k 5% 0,062W
R541 4822 051 30103 10k 5% 0,062W
R543 9965 000 13036 CHIP RES.(1608) 1/10W J 1k Ω
R544 4822 051 30103 10k 5% 0,062W
R545 4822 051 30103 10k 5% 0,062W
R546 9965 000 13036 CHIP RES.(1608) 1/10W J 1k Ω
R548 4822 051 30103 10k 5% 0,062W
R550 4822 051 30103 10k 5% 0,062W
R553 4822 051 30103 10k 5% 0,062W
R555 9965 000 13036 CHIP RES.(1608) 1/10W J 1k Ω
R557 4822 051 30103 10k 5% 0,062W
R563 4822 051 30103 10k 5% 0,062W
R565 4822 051 30103 10k 5% 0,062W
R566 9965 000 09942 CHIP RES.(1608) 1/16W J 330k Ω
R568 4822 117 12891 220k 1% ERJ3Ω
R569 4822 051 30103 10k 5% 0,062W
R572 9965 000 13036 CHIP RES.(1608) 1/10W J 1k Ω
R575 4822 051 30334 330k 5% 0,062W
R576 4822 051 30103 10k 5% 0,062W
R577 4822 051 30152 1k5 5% 0,062W
R578 9965 000 13036 CHIP RES.(1608) 1/10W J 1k Ω
R581 4822 051 30103 10k 5% 0,062W
R583 9965 000 13036 CHIP RES.(1608) 1/10W J 1k Ω
R587 9965 000 09942 CHIP RES.(1608) 1/16W J 330k Ω
R588 4822 051 30471 470Ω 5% 0,062W
R589 4822 051 30223 22k 5% 0,062W
R633 4822 051 30103 10k 5% 0,062W
R634 4822 051 30103 10k 5% 0,062W
R635 4822 051 30272 2k7 5% 0,062W
R636 4822 051 30103 10k 5% 0,062W
R637 4822 051 30562 5k6 5% 0,063W 0603 RC21 RST SM
R704 9965 000 13036 CHIP RES.(1608) 1/10W J 1k Ω
R705 9965 000 13036 CHIP RES.(1608) 1/10W J 1k Ω
R755 4822 117 12925 47k 1% 0.063W 0603
R756 9965 000 13036 CHIP RES.(1608) 1/10W J 1k Ω
R757 9965 000 13036 CHIP RES.(1608) 1/10W J 1k Ω
X301 9965 000 05629 X'TAL 4.433619MHz
X501 9965 000 12194 X'TAL 12.000MHz
X502 9965 000 12288 X'TAL 32.768KHZ(20PPM)
IC1052 9965 000 15313 1.8V REGULATOR PQ018EF01S2
IC1053 9965 000 14884 IC KIA431-AT
IC1201 9965 000 15314 IC:OP AMP KIA4558P
IC1204 9965 000 15318 FIBER OPTIC TRANS.MODULE 0C-08

-II-

C1247 9965 000 14853 ELECTROLYTIC . 470µF /16V M
 C1249 9965 000 15244 ELECTROLYTIC . 47µF /16V M
 C1351 9965 000 15300 ELECTROLYTIC . 22µF /6.3V M
 C1356 9965 000 15292 ELECTROLYTIC . 47µF /6.3V M
 C1402 4822 157 10332
 IC1402 9965 000 15319 DRIVER FOR DVD(6CH) MM1567AJBE

-II-

C1442 9965 000 14862 ELECTROLYTIC . 470µF /6.3V M
 C1445 9965 000 14862 ELECTROLYTIC . 470µF /6.3V M
 C1461 9965 000 15289 ELECTROLYTIC . 1µF /50V M
 C1462 9965 000 14862 ELECTROLYTIC . 470µF /6.3V M
 C1471 9965 000 15289 ELECTROLYTIC . 1µF /50V M
 C1481 9965 000 15289 ELECTROLYTIC . 1µF /50V M
 C1482 9965 000 14862 ELECTROLYTIC . 470µF /6.3V M
 C1486 9965 000 15291 ELECTROLYTIC . 1µF /50V M H7
 C1532 9965 000 15300 ELECTROLYTIC . 22µF /6.3V M
 CN505 4822 267 10729 10FE-BT-VK-nF
 CN701 9965 000 15351 AFV PCB ASSEMBLY CP2500/9311

-II-

D1051 9965 000 14880 PCB JUMPER D0.6-P10.0
 D1052 9965 000 15311 ZENER DIODE DZ-13BSBT265
 D1053 9965 000 14880 PCB JUMPER D0.6-P10.0
 D1056 9965 000 14880 PCB JUMPER D0.6-P10.0
 D1060 4822 130 30621 1N4148
 D1401 9965 000 12178 ZENER DIODE DZ-11BSAT265
 D1402 9965 000 12178 ZENER DIODE DZ-11BSAT265
 D1501 4822 157 10332
 IC301 9965 000 12180 IC:Y/C/A LA71750AM-MTB
 IC451 9965 000 12181 IC:HIFI LA72646M
 IC501 9965 000 15312 MICROCONTROLLER 16BIT M37762MC
 IC502 9965 000 06554 IC:MEMORY BR24C02F-W
 IC631 9965 000 12198 IC:VPS/PDC SLICER LC74793JM-TR
 IC751 9965 000 13852 IC:SWITCH TC4053BF(N) OR

~

L1251 9965 000 15331 INDUCTOR 0.47µH -K-26T
 L1521 9965 000 05627 CHOKE COIL 47µH -K

-II-

CN10019965 000 15306 FMnF CONNECTOR, SIDE 26P 26FMN-
 CN16019965 000 15307 FMnF CONNECTOR, TOP 21P 21FMN-B
 CN20029965 000 15308 FMnF CONNECTOR, SIDE 10P 10FMN-
 PS502 9965 000 12189 PHOTO INTERRUPTER RPI-302C70



Q1051 4822 130 11691 KRA110M
 Q1052 4822 130 10103 KTC3199Y
 Q1053 9965 000 15332 RES. BUILT-IN TRANSISTOR KRC11
 Q1054 9965 000 11122 KTC3205Y
 Q1055 9965 000 11123 KTA1273Y
 Q1057 4822 130 60258 2SC2001K
 Q1201 4822 130 10103 KTC3199Y
 Q1203 4822 130 42959 2SA1015Y
 Q1204 4822 130 42959 2SA1015Y
 Q1351 4822 130 10103 KTC3199Y
 Q1501 4822 130 10098 KRC103M
 Q1502 4822 130 10098 KRC103M

-II-

R1053 4822 051 30223 22k 5% 0,062W
 R1056 9965 000 09942 CHIP RES.(1608) 1/16W J 330k Ω
 R1080 4822 051 30103 10k 5% 0,062W
 R1081 4822 051 30103 10k 5% 0,062W
 R1201 4822 117 12891 220k 1% ERJ3Ω
 R1202 4822 117 12891 220k 1% ERJ3Ω
 R1203 5322 117 13028 12k 1% 0.063W 0603 RC22H
 R1204 5322 117 13028 12k 1% 0.063W 0603 RC22H
 R1205 5322 117 13032 18k 1% 0.063W 0603 RC22H
 R1206 5322 117 13032 18k 1% 0.063W 0603 RC22H
 R1207 4822 051 30393 39k 5% 0,062W
 R1208 4822 051 30393 39k 5% 0,062W
 R1209 2322 704 65603 RST SM 0603 RC22H 56k PM1 R
 R1210 2322 704 65603 RST SM 0603 RC22H 56k PM1 R
 R1211 9965 000 09942 CHIP RES.(1608) 1/16W J 330k Ω
 R1212 9965 000 09942 CHIP RES.(1608) 1/16W J 330k Ω
 R1223 9965 000 13036 CHIP RES.(1608) 1/10W J 1k Ω
 R1224 9965 000 13036 CHIP RES.(1608) 1/10W J 1k Ω
 R1225 9965 000 13036 CHIP RES.(1608) 1/10W J 1k Ω
 R1226 9965 000 13036 CHIP RES.(1608) 1/10W J 1k Ω

R1245 9965 000 09942 CHIP RES.(1608) 1/16W J 330k Ω
 R1247 4822 051 30393 39k 5% 0,062W
 R1360 9965 000 09942 CHIP RES.(1608) 1/16W J 330k Ω
 R1364 9965 000 09942 CHIP RES.(1608) 1/16W J 330k Ω
 R1502 4822 051 30103 10k 5% 0,062W
 R1521 4822 157 10332
 R2039 4822 051 30103 10k 5% 0,062W
 SW501 4822 276 13954 KSM0614B
 SW502 4822 276 13954 KSM0614B
 SW503 4822 276 13954 KSM0614B
 SW504 4822 276 13954 KSM0614B
 SW505 4822 276 13954 KSM0614B
 SW506 9965 000 15333 LEAF SWITCH LSA-1142-1AU
 SW507 9965 000 08561 ROTARY MODE SWITCH SSS-43MD
 SW508 4822 276 13954 KSM0614B
 SW511 9965 000 15334 TACT SWITCH KSM0611B



TP301 9965 000 15335 PCB JUMPER D0.6-P6.0
 TP501 4822 157 10332
 TP502 4822 157 10332
 TP503 9965 000 15335 PCB JUMPER D0.6-P6.0
 TP504 4822 157 10332
 TP751 9965 000 15336 PCB JUMPER D0.6-P28.0
 TU701 9965 000 12193 TUNER UNIT TMDG2-632A
 VR501 9965 000 05260 CARBON P.O.T. 100K OHM B
 SW20114822 276 13954 KSM0614B
 SW20124822 276 13954 KSM0614B
 SW20164822 276 13954 KSM0614B
 SW20174822 276 13954 KSM0614B

Tape Deck

Various

B2 9965 000 14827 CYLINDER ASSEMBLY MK11 PAL 4HD
 B3 9965 000 12202 LOADING MOTOR ASSEMBLY MK11
 B8 9965 000 12203 PULLEY ASSEMBLY MK11
 B9 9965 000 08560 MOVING GUIDE S PREPARATION MK1
 B10 9965 000 08431 MOVING GUIDE T PREPARATION MK1
 B11 9965 000 12204 LOADING ARM T(B) ASSEMBLY MK11
 B12 9965 000 12205 LOADING ARM S(B) ASSEMBLY MK11
 B27 9965 000 14828 TENSION LEVER SUB ASSEMBLY MK1
 B31 9965 000 12207 AC HEAD ASSEMBLY MK11
 B35 9965 000 12208 TAPE GUIDE ASSEMBLY MK11
 B37 9965 000 12209 CAPSTAN MOTOR 288/VCCM011
 B52 9965 000 08593 CAP BELT MK10
 B73 9965 000 12210 FE HEAD ASSEMBLY MK11
 B74 9965 000 08555 PRISM MK10
 B121 9965 000 12211 WORM MK11
 B126 9965 000 12212 PULLEY MK11
 B133 9965 000 12213 IDLER ASSEMBLY(2) MK10
 B148 4822 462 11189 TG CAP
 B300 9965 000 12214 C DRIVE LEVER R MK11
 B303 9965 000 12215 F DOOR OPENER MK11
 B347 9965 000 08445 GUIDE HOLDER MK10
 B354 9965 000 12216 SLIDER R MK11
 B355 9965 000 12217 SLIDER L MK11
 B359 9965 000 08449 CLEANER LEVER MK10
 B360 9965 000 06561 CLEANER ROLLER MK9
 B361 9965 000 08450 CL POST MK10
 B410 9965 000 13685 PINCH ARM(A) ASSEMBLY(Y) MK11
 B411 9965 000 08453 PINCH SPRING MK10
 B414 9965 000 12219 M BRAKE S(HI) ASSEMBLY MK11
 B416 9965 000 12220 M BRAKE T(HI) ASSEMBLY MK11
 B417 9965 000 13686 TENSION SPG(190256) MK11
 B425 9965 000 08457 LOCK LEVER SPRING MK10
 B426 9965 000 08458 KICK PULLEY MK10
 B482 9965 000 12222 C PLATE MK11
 B483 9965 000 08461 LOCK LEVER MK10
 B487 9965 000 08462 BAND BRAKE MK10
 B488 9965 000 14896 MODE LEVER(HI) MK11
 B491 9965 000 12224 CAM GEAR(A) MK11
 B492 9965 000 12225 MODE GEAR MK11
 B494 9965 000 12226 DOOR OPENER B MK11
 B499 9965 000 08467 T LEVER HOLDER MK10
 B501 9965 000 12227 WORM HOLDER MK11
 B502 9965 000 08469 CAM GEAR(B) MK10
 B505 9965 000 12372 PSCW(625504) MK11
 B507 9965 000 05342 REEL WASHER MK9 5*2.1*0.5
 B508 9965 000 14897 S BRAKE SPRING(19T) MK11
 B513 9965 000 08471 PSCW(752605) MK10
 B514 9965 000 12228 SCREW RACK MK11
 B516 9965 000 05342 REEL WASHER MK9 5*2.1*0.5
 B518 4822 532 13159 P.S.W. 1.6X4.0X0.5T
 B520 9965 000 12229 T BRAKE SPRING HI(F) MK11
 B521 9965 000 08482 SOFT SPRING MK10
 B522 9965 000 08483 TG POST ASSEMBLY MK10
 B525 9965 000 12230 LDG BELT MK11
 B529 9965 000 12231 CLEANER ASSEMBLY MK11

B551 9965 000 12232 FF ARM(HI) MK10
 B553 9965 000 12233 REV SPRING MK11
 B555 9965 000 12234 RACK ASSEMBLY MK11
 B557 9965 000 08519 MOTOR PULLEY U5
 B558 9965 000 12235 LOADING MOTOR M31E-1 R14 7351
 B559 9965 000 12236 CLUTCH ASSEMBLY(HI)(2) MK11
 B560 9965 000 08522 KICK SPRING MK10
 B562 9965 000 08524 C DRIVE LEVER L MK10
 B563 9965 000 08525 SLIDER SHAFT MK10
 B564 9965 000 12237 M GEAR(HYT) N12G5F*
 B565 9965 000 12238 SENSOR GEAR MK11
 B567 9965 000 08544 PINCH ARM(B) MK10
 B568 9965 000 08545 BT ARM MK10
 B569 9965 000 12239 CAM HOLDER F MK11
 B570 9965 000 12240 CAM RACK SPRING(HI) MK11
 B571 4822 532 13158 P.S.W. F
 B572 4822 532 13159 P.S.W. 1.6X4.0X0.5T
 B573 9965 000 12241 REEL S MK11
 B574 9965 000 12376 REEL T MK10
 B578 9965 000 12243 TR GEAR A MK10
 B579 9965 000 12244 TR GEAR B MK10
 B580 9965 000 12245 TR GEAR C MK11
 B581 9965 000 12246 CENTER GEAR(HYT) N12G5F*
 B582 9965 000 12247 TR GEAR SPRING MK10
 B583 9965 000 05342 REEL WASHER MK9 5*2.1*0.5
 B584 9965 000 12248 TR GEAR SHAFT MK10
 B585 9965 000 13687 PSW(317505) MK11
 B587 9965 000 14898 TENSION LEVER ASSEMBLY MK11

MCV CBA/001

Various

1008 9965 000 14801 SENSOR CBA

Main CBA

-II-

C055 9965 000 15242 ELECTROLYTIC . 100µF /25V M
 C056 9965 000 14863 ELECTROLYTIC . 47µF /25V M
 C058 9965 000 15243 ELECTRIC DOUBLE LAYER 0.047
 C063 9965 000 15244 ELECTROLYTIC . 47µF /16V M
 C101 9965 000 15245 ELECTROLYTIC . 4.7µF /50V M
 C102 9965 000 15245 ELECTROLYTIC . 4.7µF /50V M
 C103 9965 000 15245 ELECTROLYTIC . 4.7µF /50V M
 C104 9965 000 15246 ELECTROLYTIC . 100µF /16V M
 C107 9965 000 14862 ELECTROLYTIC . 470µF /6.3V M
 C108 9965 000 14862 ELECTROLYTIC . 470µF /6.3V M
 C117 9965 000 15289 ELECTROLYTIC . 1µF /50V M
 C121 9965 000 15246 ELECTROLYTIC . 100µF /16V M
 C251 9965 000 15290 ELECTROLYTIC . 10µF /16V M H
 C254 9965 000 15291 ELECTROLYTIC . 1µF /50V M H7
 C302 9965 000 15291 ELECTROLYTIC . 1µF /50V M H7
 C305 9965 000 15291 ELECTROLYTIC . 1µF /50V M H7
 C312 9965 000 15290 ELECTROLYTIC . 10µF /16V M H
 C313 9965 000 15291 ELECTROLYTIC . 1µF /50V M H7
 C316 9965 000 15291 ELECTROLYTIC . 1µF /50V M H7
 C328 9965 000 15292 ELECTROLYTIC . 47µF /6.3V M
 C330 9965 000 15293 ELECTROLYTIC . 100µF /16V M
 C331 9965 000 15294 ELECTROLYTIC . 220µF /6.3V M
 C334 9965 000 15291 ELECTROLYTIC . 1µF /50V M H7
 C335 9965 000 15295 ELECTROLYTIC . 100µF /6.3V H
 C340 9965 000 15291 ELECTROLYTIC . 1µF /50V M H7
 C343 9965 000 15290 ELECTROLYTIC . 10µF /16V M H
 C344 9965 000 15296 ELECTROLYTIC . 4.7µF /25V M
 C345 9965 000 15297 ELECTROLYTIC . 0.47µF /50V M
 C405 9965 000 15292 ELECTROLYTIC . 47µF /6.3V M
 C406 9965 000 15298 ELECTROLYTIC . 4.7µF /25V M
 C410 9965 000 15290 ELECTROLYTIC . 10µF /16V M H
 C412 9965 000 15299 ELECTROLYTIC . 33µF /6.3V M
 C415 9965 000 15298 ELECTROLYTIC . 4.7µF /25V M
 C417 9965 000 15300 ELECTROLYTIC . 22µF /6.3V M
 C421 9965 000 15292 ELECTROLYTIC . 47µF /6.3V M
 C451 9965 000 15298 ELECTROLYTIC . 4.7µF /25V M
 C454 9965 000 15301 ELECTROLYTIC . 2.2µF /50V M
 C455 9965 000 15301 ELECTROLYTIC . 2.2µF /50V M
 C456 9965 000 15290 ELECTROLYTIC . 10µF /16V M H
 C457 9965 000 15298 ELECTROLYTIC . 4.7µF /25V M
 C458 9965 000 15298 ELECTROLYTIC . 4.7µF /25V M
 C459 9965 000 15298 ELECTROLYTIC . 4.7µF /25V M
 C460 9965 000 15302 ELECTROLYTIC . 47µF /16V M H
 C462 9965 000 15290 ELECTROLYTIC . 10µF /16V M H
 C463 9965 000 15290 ELECTROLYTIC . 10µF /16V M H
 C468 9965 000 15290 ELECTROLYTIC . 10µF /16V M H
 C469 9965 000 15303 ELECTROLYTIC . 22µF /10V M H
 C470 9965 000 15298 ELECTROLYTIC . 4.7µF /25V M
 C471 9965 000 15290 ELECTROLYTIC . 10µF /16V M H
 C473 9965 000 15298 ELECTROLYTIC . 4.7µF /25V M
 C475 9965 000 15303 ELECTROLYTIC . 22µF /10V M H

C478 9965 000 15303 ELECTROLYTIC . 22µF /10V M H
 C479 9965 000 15298 ELECTROLYTIC . 4.7µF /25V M
 C480 9965 000 15290 ELECTROLYTIC . 10µF /16V M H
 C506 9965 000 15294 ELECTROLYTIC . 220µF /6.3V M
 C511 4822 126 12787 330pF 10% 50V
 C514 4822 126 12787 330pF 10% 50V
 C516 9965 000 15300 ELECTROLYTIC . 22µF /6.3V M
 C521 9965 000 15300 ELECTROLYTIC . 22µF /6.3V M
 C534 9965 000 15292 ELECTROLYTIC . 47µF /6.3V M
 C549 9965 000 15291 ELECTROLYTIC . 1µF /50V M H7
 C550 9965 000 15295 ELECTROLYTIC . 100µF /6.3V H
 C553 9965 000 15303 ELECTROLYTIC . 22µF /10V M H
 C632 9965 000 15291 ELECTROLYTIC . 1µF /50V M H7
 C633 9965 000 15291 ELECTROLYTIC . 1µF /50V M H7
 C635 9965 000 12290 SEMICONDUCTOR . SR K 0.056U
 C636 9965 000 15298 ELECTROLYTIC . 4.7µF /25V M
 C637 9965 000 15292 ELECTROLYTIC . 47µF /6.3V M
 C701 9965 000 15295 ELECTROLYTIC . 100µF /6.3V H
 C708 9965 000 15290 ELECTROLYTIC . 10µF /16V M H
 C752 9965 000 15304 ELECTROLYTIC . 47µF /10V M
 C753 9965 000 15245 ELECTROLYTIC . 4.7µF /50V M
 C754 9965 000 15245 ELECTROLYTIC . 4.7µF /50V M

→←

D051 4822 157 10332
 D052 5322 130 81917 SB140
 D053 4822 130 31933 1N5061
 D054 9965 000 09283 ZENER DIODE DZ-10BSBT265
 D055 4822 130 31933 1N5061
 D056 4822 130 30621 1N4148
 D057 5322 130 81917 SB140
 D101 9965 000 12178 ZENER DIODE DZ-11BSAT265
 D102 9965 000 12178 ZENER DIODE DZ-11BSAT265
 D103 9965 000 12178 ZENER DIODE DZ-11BSAT265
 D104 9965 000 12178 ZENER DIODE DZ-11BSAT265
 D105 9965 000 12178 ZENER DIODE DZ-11BSAT265
 D106 9965 000 12178 ZENER DIODE DZ-11BSAT265
 D107 9965 000 12178 ZENER DIODE DZ-11BSAT265
 D108 9965 000 12178 ZENER DIODE DZ-11BSAT265
 D109 9965 000 12178 ZENER DIODE DZ-11BSAT265
 D110 9965 000 12178 ZENER DIODE DZ-11BSAT265
 D112 9965 000 12178 ZENER DIODE DZ-11BSAT265
 D113 9965 000 12178 ZENER DIODE DZ-11BSAT265
 D115 9965 000 12178 ZENER DIODE DZ-11BSAT265
 D118 9965 000 12178 ZENER DIODE DZ-11BSAT265
 D119 9965 000 12178 ZENER DIODE DZ-11BSAT265
 D121 9965 000 12178 ZENER DIODE DZ-11BSAT265
 D301 4822 130 30621 1N4148
 D506 9965 000 08623 LED(GREEN) 204-10GD/S957
 D507 9965 000 08623 LED(GREEN) 204-10GD/S957
 D508 9965 000 08621 LED(RED) 204HD/E
 D510 4822 130 30621 1N4148
 D511 9965 000 15309 ZENER DIODE DZ-7.5BSAT265
 D512 4822 130 30621 1N4148
 D513 4822 130 30621 1N4148
 D555 9965 000 05250 LED SIR-563ST3F P
 D701 9965 000 09183 ZENER DIODE DZ-33BSDT265
 D751 9965 000 15310 ZENER DIODE DZ-8.2BSAT265

~

L051 4822 157 10332
 L052 9965 000 05627 CHOKE COIL 47µH -K
 L053 4822 157 10649 100µH
 L101 4822 526 10685 BEAD CORE
 L102 4822 526 10685 BEAD CORE
 L251 9965 000 08652 INDUCTOR 5.6µH -K-26T
 L302 4822 157 63316
 L401 9965 000 05627 CHOKE COIL 47µH -K
 L402 9965 000 05705 INDUCTOR 47µH -K-5FT
 L451 9965 000 05627 CHOKE COIL 47µH -K
 L452 9965 000 05627 CHOKE COIL 47µH -K
 L501 4822 157 10649 100µH
 L502 4822 157 10332
 L503 9965 000 08629 INDUCTOR 1.8µH -K-26T
 L701 4822 157 11511 15µH -K-26T
 L702 4822 157 10332
 L703 9965 000 05627 CHOKE COIL 47µH -K
 L704 4822 157 10889 10µH

⊗

Q051 9965 000 12190 TRANSISTOR KTA1281(Y)
 Q052 4822 130 10098 KRC103M
 Q053 4822 130 42292 2SC2120Y
 Q054 4822 130 10098 KRC103M
 Q055 4822 130 10103 KTC3199Y
 Q056 4822 130 42292 2SC2120Y
 Q057 4822 130 10145 KRA103M
 Q101 4822 130 10103 KTC3199Y
 Q102 4822 130 10103 KTC3199Y

Q103 4822 130 42959 2SA1015Y
 Q104 4822 130 42959 2SA1015Y
 Q105 4822 130 10103 KTC3199Y
 Q301 4822 130 42959 2SA1015Y
 Q302 4822 130 10103 KTC3199Y
 Q401 4822 130 10103 KTC3199Y
 Q402 4822 130 10103 KTC3199Y
 Q403 4822 130 42292 2SC2120Y
 Q404 4822 130 42959 2SA1015Y
 Q405 4822 130 10145 KRA103M
 Q406 4822 130 10103 KTC3199Y
 Q451 4822 130 10098 KRC103M
 Q501 4822 130 10103 KTC3199Y
 Q502 4822 130 10103 KTC3199Y
 Q506 9965 000 08630 PHOTO TRANSISTOR PT204-6B-12
 Q507 4822 130 10103 KTC3199Y
 Q508 4822 130 10103 KTC3199Y
 Q509 4822 130 10103 KTC3199Y
 Q510 4822 130 10098 KRC103M
 Q511 4822 130 10103 KTC3199Y
 Q513 4822 130 10098 KRC103M
 Q514 4822 130 10923 KTC3199(BL)
 Q515 4822 130 10923 KTC3199(BL)
 Q752 4822 130 10098 KRC103M



R054 4822 051 30223 22k 5% 0,062W
 R064 4822 157 10332
 R065 4822 051 30223 22k 5% 0,062W
 R101 4822 117 12925 47k 1% 0.063W 0603
 R102 4822 117 12925 47k 1% 0.063W 0603
 R122 4822 051 30103 10k 5% 0,062W
 R134 9965 000 10005 CHIP RES.(1608) 1/10W J 22 Ω
 R140 4822 051 30223 22k 5% 0,062W
 R251 4822 051 30393 39k 5% 0,062W
 R301 9965 000 09966 CHIP RES.(1608) 1/10W J 390k Ω
 R303 4822 051 30562 5k6 5% 0,063W 0603 RC21 RST SM
 R304 9965 000 09942 CHIP RES.(1608) 1/16W J 330k Ω
 R305 4822 051 30103 10k 5% 0,062W
 R315 9965 000 13036 CHIP RES.(1608) 1/10W J 1k Ω
 R319 9965 000 13036 CHIP RES.(1608) 1/10W J 1k Ω
 R320 4822 051 30393 39k 5% 0,062W
 R322 4822 051 30103 10k 5% 0,062W
 R325 9965 000 09966 CHIP RES.(1608) 1/10W J 390k Ω
 R327 9965 000 10005 CHIP RES.(1608) 1/10W J 22 Ω
 R328 4822 051 30561 560Ω 5% 0,062W
 R331 4822 051 30183 18k 5% 0,062W
 R332 4822 051 30103 10k 5% 0,062W
 R333 4822 051 30183 18k 5% 0,062W
 R334 4822 051 30103 10k 5% 0,062W
 R337 9965 000 10005 CHIP RES.(1608) 1/10W J 22 Ω
 R339 9965 000 09942 CHIP RES.(1608) 1/16W J 330k Ω
 R403 4822 051 30103 10k 5% 0,062W
 R404 4822 051 30103 10k 5% 0,062W
 R405 4822 117 12925 47k 1% 0.063W 0603
 R406 4822 051 30223 22k 5% 0,062W
 R407 4822 051 30562 5k6 5% 0,063W 0603 RC21 RST SM
 R409 4822 051 30562 5k6 5% 0,063W 0603 RC21 RST SM
 R410 9965 000 13036 CHIP RES.(1608) 1/10W J 1k Ω
 R413 4822 051 30334 330k 5% 0,062W
 R416 9965 000 09966 CHIP RES.(1608) 1/10W J 390k Ω
 R419 4822 051 30103 10k 5% 0,062W
 R420 9965 000 09214 CARBON RES. 1/6W J 5.6k Ω
 R452 9965 000 10005 CHIP RES.(1608) 1/10W J 22 Ω
 R453 9965 000 10005 CHIP RES.(1608) 1/10W J 22 Ω
 R454 9965 000 10005 CHIP RES.(1608) 1/10W J 22 Ω
 R455 4822 051 30393 39k 5% 0,062W
 R456 4822 051 30393 39k 5% 0,062W
 R458 9965 000 13036 CHIP RES.(1608) 1/10W J 1k Ω
 R459 9965 000 13036 CHIP RES.(1608) 1/10W J 1k Ω
 R460 9965 000 10005 CHIP RES.(1608) 1/10W J 22 Ω
 R461 4822 051 30223 22k 5% 0,062W
 R462 4822 117 12902 8k2 1% 0.063W 0603
 R463 9965 000 10005 CHIP RES.(1608) 1/10W J 22 Ω
 R464 4822 051 30393 39k 5% 0,062W
 R465 4822 051 30393 39k 5% 0,062W
 R466 4822 117 12902 8k2 1% 0.063W 0603
 R467 9965 000 10005 CHIP RES.(1608) 1/10W J 22 Ω
 R468 4822 051 30393 39k 5% 0,062W
 R469 4822 051 30393 39k 5% 0,062W
 R470 9965 000 10005 CHIP RES.(1608) 1/10W J 22 Ω
 R471 4822 117 12902 8k2 1% 0.063W 0603
 R475 4822 051 30471 470Ω 5% 0,062W
 R476 4822 051 30103 10k 5% 0,062W
 R502 9965 000 13036 CHIP RES.(1608) 1/10W J 1k Ω
 R503 9965 000 09966 CHIP RES.(1608) 1/10W J 390k Ω
 R504 4822 051 30152 1k5 5% 0,062W
 R507 4822 117 12902 8k2 1% 0.063W 0603
 R537 4822 051 30681 680Ω 5% 0,062W
 R538 4822 051 30152 1k5 5% 0,062W
 R539 4822 051 30103 10k 5% 0,062W
 R540 4822 051 30103 10k 5% 0,062W

R541 4822 051 30103 10k 5% 0,062W
 R543 9965 000 13036 CHIP RES.(1608) 1/10W J 1k Ω
 R544 4822 051 30103 10k 5% 0,062W
 R545 4822 051 30103 10k 5% 0,062W
 R546 9965 000 13036 CHIP RES.(1608) 1/10W J 1k Ω
 R547 4822 051 30103 10k 5% 0,062W
 R550 4822 051 30103 10k 5% 0,062W
 R553 4822 051 30103 10k 5% 0,062W
 R555 9965 000 13036 CHIP RES.(1608) 1/10W J 1k Ω
 R557 4822 051 30103 10k 5% 0,062W
 R563 4822 051 30103 10k 5% 0,062W
 R565 4822 051 30103 10k 5% 0,062W
 R566 9965 000 09942 CHIP RES.(1608) 1/16W J 330k Ω
 R568 4822 117 12891 220k 1% ERJ3Ω
 R569 4822 051 30103 10k 5% 0,062W
 R572 9965 000 13036 CHIP RES.(1608) 1/10W J 1k Ω
 R575 4822 051 30334 330k 5% 0,062W
 R576 4822 051 30103 10k 5% 0,062W
 R577 4822 051 30152 1k5 5% 0,062W
 R578 9965 000 13036 CHIP RES.(1608) 1/10W J 1k Ω
 R581 4822 051 30103 10k 5% 0,062W
 R583 9965 000 13036 CHIP RES.(1608) 1/10W J 1k Ω
 R587 9965 000 09942 CHIP RES.(1608) 1/16W J 330k Ω
 R588 4822 051 30471 470Ω 5% 0,062W
 R589 4822 051 30223 22k 5% 0,062W
 R633 4822 051 30103 10k 5% 0,062W
 R634 4822 051 30103 10k 5% 0,062W
 R635 4822 051 30272 2k7 5% 0,062W
 R636 4822 051 30103 10k 5% 0,062W
 R637 4822 051 30562 5k6 5% 0,063W 0603 RC21 RST SM
 R704 9965 000 13036 CHIP RES.(1608) 1/10W J 1k Ω
 R705 9965 000 13036 CHIP RES.(1608) 1/10W J 1k Ω
 R755 4822 117 12925 47k 1% 0.063W 0603
 R756 9965 000 13036 CHIP RES.(1608) 1/10W J 1k Ω
 R757 9965 000 13036 CHIP RES.(1608) 1/10W J 1k Ω
 X301 9965 000 05629 X'TAL 4.433619MHz
 X501 9965 000 12194 X'TAL 12.000MHz
 X502 9965 000 12288 X'TAL 32.768KHZ(20PPM)
 IC1052 9965 000 15313 1.8V REGULATOR PQ018EF01SZ
 IC1053 9965 000 14884 IC KIA431-AT
 IC1201 9965 000 15314 IC:OP AMP KIA4558P
 IC1204 9965 000 15318 FIBER OPTIC TRANS.MODULE 0C-08



C1247 9965 000 14853 ELECTROLYTIC . 470μF /16V M
 C1249 9965 000 15244 ELECTROLYTIC . 47μF /16V M
 C1351 9965 000 15300 ELECTROLYTIC . 22μF /6.3V M
 C1356 9965 000 15292 ELECTROLYTIC . 47μF /6.3V M
 C1402 4822 157 10332
 IC1402 9965 000 15319 DRIVER FOR DVD(6CH) MM1567AJBE



C1442 9965 000 14862 ELECTROLYTIC . 470μF /6.3V M
 C1445 9965 000 14862 ELECTROLYTIC . 470μF /6.3V M
 C1461 9965 000 15289 ELECTROLYTIC . 1μF /50V M
 C1462 9965 000 14862 ELECTROLYTIC . 470μF /6.3V M
 C1471 9965 000 15289 ELECTROLYTIC . 1μF /50V M
 C1481 9965 000 15289 ELECTROLYTIC . 1μF /50V M
 C1482 9965 000 14862 ELECTROLYTIC . 470μF /6.3V M
 C1486 9965 000 15291 ELECTROLYTIC . 1μF /50V M H7
 C1532 9965 000 15300 ELECTROLYTIC . 22μF /6.3V M
 CN505 4822 267 10729 10FE-BT-VK-nF
 CN701 9965 000 15305 AFV PCB ASSEMBLY CP2500/9300



D1051 9965 000 14880 PCB JUMPER D0.6-P10.0
 D1052 9965 000 15311 ZENER DIODE DZ-13BSBT265
 D1053 9965 000 14880 PCB JUMPER D0.6-P10.0
 D1056 9965 000 14880 PCB JUMPER D0.6-P10.0
 D1060 4822 130 30621 1N4148
 D1401 9965 000 12178 ZENER DIODE DZ-11BSAT265
 D1402 9965 000 12178 ZENER DIODE DZ-11BSAT265
 D1501 4822 157 10332
 IC301 9965 000 12180 IC:Y/C/A LA71750AM-MTB
 IC451 9965 000 12181 IC:HIFI LA72646M
 IC501 9965 000 15312 MICROCONTROLLER 16BIT M37762MC
 IC502 9965 000 06554 IC:MEMORY BR24C02F-W
 IC631 9965 000 12198 IC:VPS/PDC SLICER LC74793JM-TR
 IC751 9965 000 13852 IC:SWITCH TC4053BF(N) OR



L1251 9965 000 15331 INDUCTOR 0.47μH -K-26T
 L1521 9965 000 05627 CHOKE COIL 47μH -K



CN10019965 000 15306 FMnF CONNECTOR, SIDE 26P 26FMN-

CN16019965 000 15307 FMnF CONNECTOR, TOP 21P 21FMN-B
CN20029965 000 15308 FMnF CONNECTOR, SIDE 10P 10FMN-
PS502 9965 000 12189 PHOTO INTERRUPTER RPI-302C70



Q1051 4822 130 11691 KRA110M
Q1052 4822 130 10103 KTC3199Y
Q1053 9965 000 15332 RES. BUILT-IN TRANSISTOR KRC11
Q1054 9965 000 11122 KTC3205Y
Q1055 9965 000 11123 KTA1273Y
Q1057 4822 130 60258 2SC2001K
Q1201 4822 130 10103 KTC3199Y
Q1202 4822 130 10103 KTC3199Y
Q1203 4822 130 42959 2SA1015Y
Q1204 4822 130 42959 2SA1015Y
Q1351 4822 130 10103 KTC3199Y
Q1501 4822 130 10098 KRC103M
Q1502 4822 130 10098 KRC103M



R1053 4822 051 30223 22k 5% 0,062W
R1056 9965 000 09942 CHIP RES.(1608) 1/16W J 330k Ω
R1080 4822 051 30103 10k 5% 0,062W
R1081 4822 051 30103 10k 5% 0,062W
R1201 4822 117 12891 220k 1% ERJ3Ω
R1202 4822 117 12891 220k 1% ERJ3Ω
R1203 5322 117 13028 12k 1% 0.063W 0603 RC22H
R1204 5322 117 13028 12k 1% 0.063W 0603 RC22H
R1205 5322 117 13032 18k 1% 0.063W 0603 RC22H
R1206 5322 117 13032 18k 1% 0.063W 0603 RC22H
R1207 4822 051 30393 39k 5% 0,062W
R1208 4822 051 30393 39k 5% 0,062W
R1209 2322 704 65603 RST SM 0603 RC22H 56k PM1 R
R1210 2322 704 65603 RST SM 0603 RC22H 56k PM1 R
R1211 9965 000 09942 CHIP RES.(1608) 1/16W J 330k Ω
R1212 9965 000 09942 CHIP RES.(1608) 1/16W J 330k Ω
R1223 9965 000 13036 CHIP RES.(1608) 1/10W J 1k Ω
R1224 9965 000 13036 CHIP RES.(1608) 1/10W J 1k Ω
R1225 9965 000 13036 CHIP RES.(1608) 1/10W J 1k Ω
R1226 9965 000 13036 CHIP RES.(1608) 1/10W J 1k Ω
R1245 9965 000 09942 CHIP RES.(1608) 1/16W J 330k Ω
R1247 4822 051 30393 39k 5% 0,062W
R1360 9965 000 09942 CHIP RES.(1608) 1/16W J 330k Ω
R1364 9965 000 09942 CHIP RES.(1608) 1/16W J 330k Ω
R1502 4822 051 30103 10k 5% 0,062W
R1521 4822 157 10332
R2039 4822 051 30103 10k 5% 0,062W
SW501 4822 276 13954 KSM0614B
SW502 4822 276 13954 KSM0614B
SW503 4822 276 13954 KSM0614B
SW504 4822 276 13954 KSM0614B
SW505 4822 276 13954 KSM0614B
SW506 9965 000 15333 LEAF SWITCH LSA-1142-1AU
SW507 9965 000 08561 ROTARY MODE SWITCH SSS-43MD
SW508 4822 276 13954 KSM0614B
SW511 9965 000 15334 TACT SWITCH KSM0611B



TP301 9965 000 15335 PCB JUMPER D0.6-P6.0
TP501 4822 157 10332
TP502 4822 157 10332
TP503 9965 000 15335 PCB JUMPER D0.6-P6.0
TP504 4822 157 10332
TP751 9965 000 15336 PCB JUMPER D0.6-P28.0
TU701 9965 000 12265 TUNER UNIT TMDG2-631A
VR501 9965 000 05260 CARBON P.O.T. 100K OHM B
SW20114822 276 13954 KSM0614B
SW20124822 276 13954 KSM0614B
SW20164822 276 13954 KSM0614B
SW20174822 276 13954 KSM0614B

Function CBA

IC2001 9965 000 15339 FL DRIVER IC PT6315-S(-)TP



C2004 9965 000 15295 ELECTROLYTIC . 100μF /6.3V H
C2055 9965 000 15337 ELECTROLYTIC . 22μF /50V M H



D2001 4822 130 30621 1N4148
D2003 4822 130 30621 1N4148
D2004 4822 130 30621 1N4148
D2005 4822 130 30621 1N4148

L2001 4822 157 10649 100μH
FL2001 9965 000 15338 V.F.D. 20U29100SAN



L2003 4822 157 10332
L2004 4822 157 10332



RM20019965 000 10857 REMOTE RECEIVER



CN20019965 000 15308 FMnF CONNECTOR, SIDE 10P 10FMN-



Q2022 4822 130 42959 2SA1015Y



R1041 4822 157 10332
R2002 4822 051 30103 10k 5% 0,062W
R2003 4822 051 30103 10k 5% 0,062W
R2010 9965 000 13036 CHIP RES.(1608) 1/10W J 1k Ω
R2011 4822 051 30103 10k 5% 0,062W
R2037 4822 157 10332
R2038 4822 051 30103 10k 5% 0,062W
R2059 9965 000 09942 CHIP RES.(1608) 1/16W J 330k Ω
SW20144822 276 13954 KSM0614B

Front jack CBA



D651 9965 000 08621 LED(RED) 204HD/E
D652 9965 000 08621 LED(RED) 204HD/E
D653 9965 000 08623 LED(GREEN) 204-10GD/S957



R655 9965 000 13036 CHIP RES.(1608) 1/10W J 1k Ω
R656 9965 000 09966 CHIP RES.(1608) 1/10W J 390k Ω



CN651 4822 267 10729 10FE-BT-VK-nF
SW651 4822 276 13954 KSM0614B
SW652 4822 276 13954 KSM0614B
SW653 4822 276 13954 KSM0614B
SW654 4822 276 13954 KSM0614B

Junction A CBA



CN050 9965 000 15343 CONNECTOR, 14P TUC-P14X-B1

Junction B CBA

CN051 9965 000 13917 CONNECTOR, 6P TUC-P06X-B1

DVD CBA



Q503 9965 000 08630 PHOTO TRANSISTOR PT204-6B-12
Q504 9965 000 08630 PHOTO TRANSISTOR PT204-6B-12

PSU CBA



C013 9965 000 14852 ELECTROLYTIC . 10μF /50V M
C018 9965 000 14853 ELECTROLYTIC . 470μF /16V M



D013 4822 130 41487 BYV95C
 D015 4822 130 83883 FR202
 D019 9965 000 14880 PCB JUMPER D0.6-P10.0
 D020 4822 157 10332



L008 9965 000 05627 CHOKE COIL 47μH -K
 F1001! 4822 070 31602 21801.6(1.6A)



Q1001! 9965 000 05255 FET FS2KM-18A



L1003! 9965 000 12188 LINE TER 50mH LF-4Z-E503



C1006! 9965 000 06522 SAFTY . 2200pF /250V
 IC1001 4822 130 11655 LTV817B-F



C1002 9965 000 14855 ELECTROLYTIC . 22μF /50V M
 IC1002 9965 000 14884 IC KIA431-AT



C1003 4822 126 14142 0.01μF 500V
 C1004 9965 000 14856 ELECTROLYTIC . 33μF /400V M
 C1005 4822 126 14141 56pF 1KV
 C1007 4822 124 12427 1000μF 20% 10V
 C1008 9965 000 14857 ELECTROLYTIC . 1000μF /16V M
 C1012 9965 000 14858 ELECTROLYTIC . 470μF /25V M
 C1018 9965 000 14859 ELECTROLYTIC . 100μF /10V M
 C1035 9965 000 14853 ELECTROLYTIC . 470μF /16V M
 C1038 9965 000 14862 ELECTROLYTIC . 470μF /6.3V M
 IC1041 9965 000 14885 3.3V REGULATOR KIA78R33PI



C1044 9965 000 14863 ELECTROLYTIC . 47μF /25V M
 C1048 9965 000 14864 ELECTROLYTIC . 220μF /16V M
 CN001 9965 000 14879 CONNECTOR BASE, 14P TUC-P14P-B
 CN002 9965 000 13843 CONNECTOR BASE, 6P TUC-P06P-B1



D1001 4822 130 31933 1N5061
 D1002 4822 130 31933 1N5061
 D1003 4822 130 31933 1N5061
 D1004 4822 130 31933 1N5061
 D1005 5322 130 80285 SB350
 D1006 4822 130 30621 1N4148
 D1007 4822 157 10332
 D1008 4822 130 32715 SB340
 D1009 4822 130 83883 FR202
 D1010 4822 130 41487 BYV95C
 D1011 5322 130 34979 BYV96E
 D1012 4822 130 30621 1N4148
 D1013 9965 000 09323 ZENER DIODE DZ-9.1BSCT265
 D1014 9965 000 09182 ZENER DIODE DZ-5.1BSCT265
 D1015 9965 000 14881 ZENER DIODE DZ-6.8BSBT265
 D1016 9965 000 14882 RECTIFIER DIODE FR101
 D1017 9965 000 14883 ZENER DIODE DZ-18BSCT265
 D1018 4822 130 30621 1N4148
 D1022 4822 130 30621 1N4148
 D1024 4822 130 30621 1N4148
 D1025 4822 130 30621 1N4148
 D1030 4822 130 83883 FR202
 D1041 4822 130 31933 1N5061
 D1042 4822 130 31933 1N5061
 D1043 4822 130 31933 1N5061
 FH1001 4822 256 10461 FUSE HOLDER MSF-015
 FH1002 4822 256 10461 FUSE HOLDER MSF-015



L1001 4822 526 10685 BEAD CORE
 L1002 4822 526 10685 BEAD CORE
 L1006 9965 000 05627 CHOKE COIL 47μH -K
 L1007 9965 000 05627 CHOKE COIL 47μH -K
 L1008 9965 000 05627 CHOKE COIL 47μH -K

L1009 9965 000 05627 CHOKE COIL 47μH -K



Q1003 4822 130 10103 KTC3199Y
 Q1008 4822 130 10103 KTC3199Y



R1011 9965 000 08633 METAL OXIDE FILM RES. 1W J 1.8
 R1040 4822 157 10332



T001! 9965 000 14886 PULSE TRANS CSA-SW0120A

AFV CBA

Various

D2 4822 130 30621 1N4148
 D2 4822 130 32778 1SS133
 L1 4822 157 10889 10UH
 L2 4822 157 10332
 L3 4822 157 11318 18UH 10%
 L4 4822 157 10889 10UH
 R1 9965 000 13036 CHIP RES.(1608) 1/10W J 1K OHM
 R4 9965 000 13037 CHIP RES.(1608) 1/10W J 120K O
 R5 9965 000 09942 CHIP RES.(1608) 1/16W J 330K O
 R6 9965 000 09942 CHIP RES.(1608) 1/16W J 330K O
 X1 9965 000 12200 X'TAL 18.432MHZ
 C12 9965 000 14891 ELECTROLYTIC CAP. 10UF/16V M H
 C15 9965 000 14891 ELECTROLYTIC CAP. 10UF/16V M H
 C16 9965 000 14891 ELECTROLYTIC CAP. 10UF/16V M H
 C20 9965 000 14892 ELECTROLYTIC CAP. 3.3UF/50V M
 C22 9965 000 14891 ELECTROLYTIC CAP. 10UF/16V M H
 C24 9965 000 14893 ELECTROLYTIC CAP. 0.22UF/50V M
 CN1 4822 265 11267 ANGLE PIN HEADER 9P
 IC1 9965 000 12274 IC:AUDIO PROCESSOR MSP3407G-QG